

General Specifications

Link-Belt®

GENERAL INFORMATION ONLY

Hydraulic Cab Down Crane

HCD-80B 15 tons (13.64 metric tons)

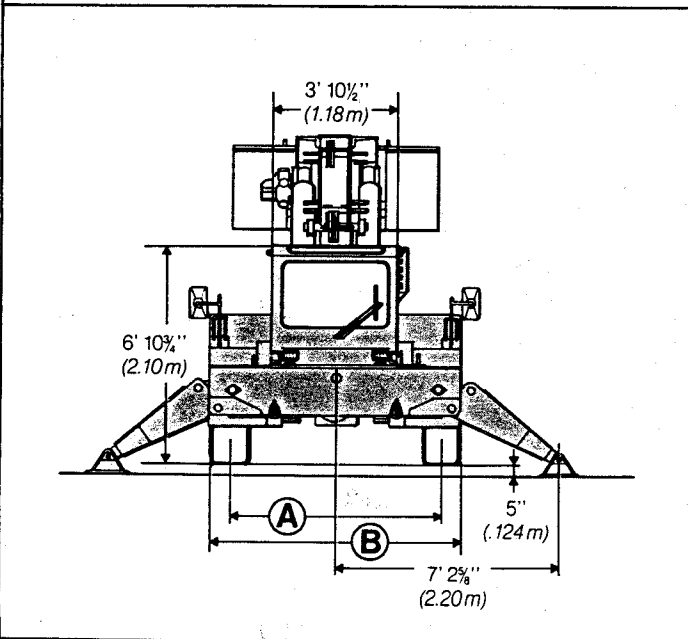
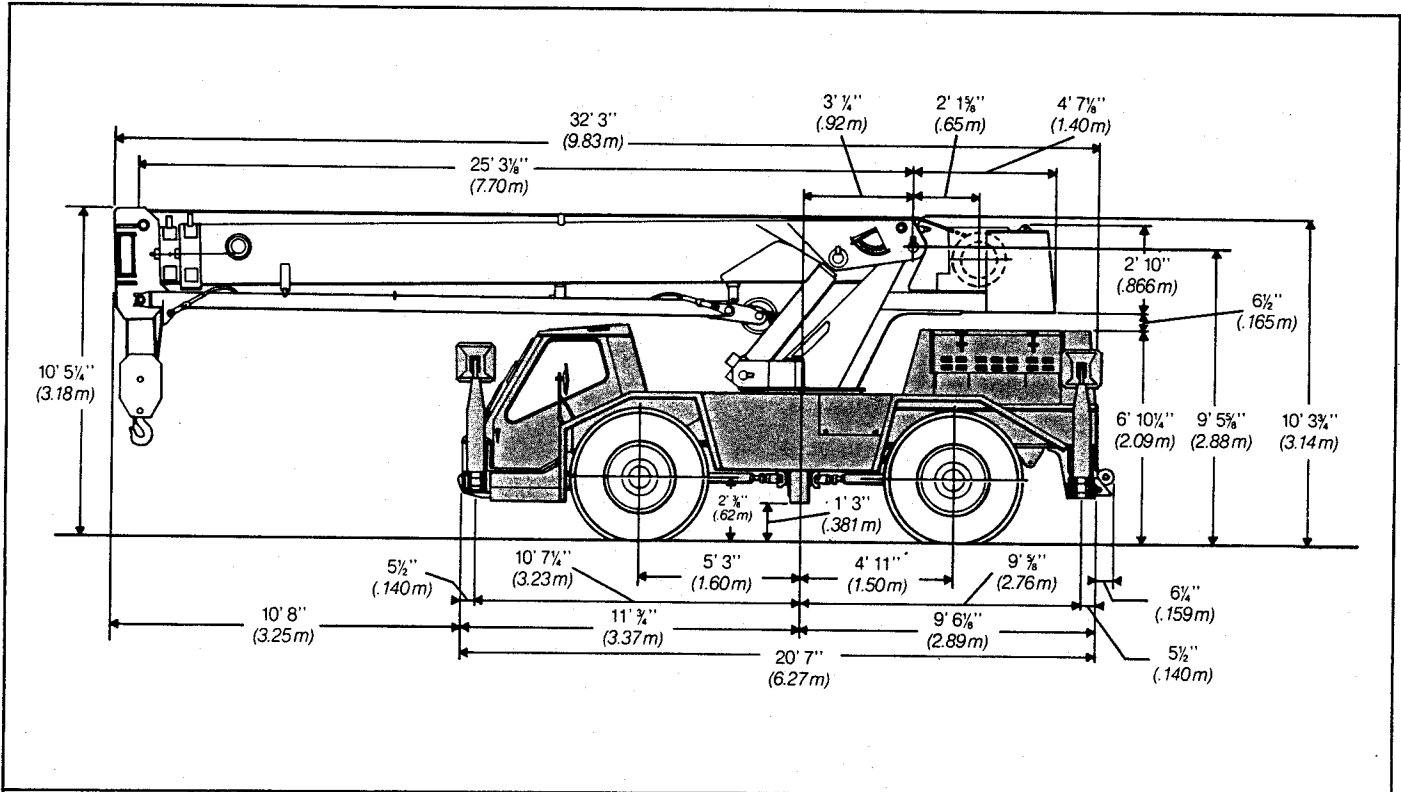

General dimensions	Feet	meters
Turning radius (4-wheel steer)	15' 9"	4.80
Tailswing of counterweight	8' 10"	2.69

Dimensions affected by tires

Tires	14.0 x 24 (20-PR)		17.5 x 25 (20-PR)	
	Feet	meters	Feet	meters
A	6' 9 1/4"	2.06	6' 10 1/4"	2.08
B	8'	2.43	8' 3"	2.52

Upperstructure



Boom

5' - 60' (7.62 - 18.29 m) 3-section tower boom. Boom telescope sections are supported by wear shoes both vertically and horizontally to prevent metal to metal contact.

Boom head — Two 9-5/8" (245 mm) root diameter sheaves standard. Three head sheaves are available to handle up to 7 parts of wire rope. Two easily removable wire rope guards and rope dead end lugs for 2-4-6 parts of line. Optional 12-7/8" (326 mm) root diameter head sheaves meet 25:1 ratio European Safety Code with 14 mm wire rope.

Boom elevation — Two hydraulic cylinders with holding valves. Hand control lever for controlling boom elevation from -1° to 75°. Mechanical boom angle indicator standard.

ly
Optional; 20' 0" (6.10 m) stowable one-piece lattice type.

ib
Optional; 20' 0" (6.10 m) stowable frame. Attaches to boom head only. Can be offset 0°, 15°, and 30°.



Swing

Bi-directional hydraulic swing motor mounted to a planetary reducer for 360° continuous smooth swing at 3.0 rpm.

Swing brake — Automatically applied and released, disc brake coupled to the speed reducer.

Swing lock — Standard two-position pin-type (over front and rear) operated manually.

Counterweight — Bolted to upperstructure frame.



Hydraulic System

Main pump — Double gear-type pump. Powered by carrier engine through hot-shift pump disconnect which can be engaged/disengaged while engine is running.

Swing/steering pump — Tandem pump. Powered by carrier engine through a straight mechanical drive.

Reservoir — 93 gallon (352 L) capacity.

Filtration — Two 10 micron filters, located outside of hydraulic reservoir for easy replacement.

Control valves — 4 separate control valves allow simultaneous operation of all crane functions.

GENERAL INFORMATION ONLY



Load hoist system

Standard: Main winch with two speed and automatic brake; power up/power down mode of operation. Bi-directional radial piston hydraulic motor, driven through a spur gear reduction unit for positive operator control under all load conditions.

Line pulls and speeds — Maximum permissible line pull 7,978 lbs. (3618 kg.) and maximum line speed of 420 fpm (128 m/min.) on standard 13-9/16" (345 mm) root diameter grooved drum.

Standard upperstructure equipment
Boom length and boom angle indicator, two-speed main winch, grooved drum, 15-ton hook block, anti-two block with function kickout and audible alarm.

Chassis

GENERAL INFORMATION ONLY



Type

8' (2.43 m) wide, 122" (3099 mm) wheelbase.

4x4x4 — (4 wheel steer, 4 wheel drive). Standard; crab steering allows steering to either side simultaneously.

Frame — All welded box section main frame with integral front and rear outrigger boxes.



Cab and Controls

Environmental cab — All windows fixed, safety glass used for front window. Slide-by-door opens to 2'2" (.66 m) width. 4-way adjustable operators seat. Cab door is key locked. Control levers for swing, boom telescope, winch and boom hoist, and outriggers.

Cab instrumentation — Dash mounted gauges for engine oil pressure, hydraulic oil temperature, converter temperature, fuel and voltmeter.



Outriggers

Four hydraulic cantilever outriggers. Outrigger cylinders individually controlled from cab. Extend to 14' 5-1/4" (4.4 m). Equipped with 18" (.46 m) square steel floats. Sight level bubble located in cab.



Axles

Front — Standard; heavy duty planetary drive/steer type.

Rear — Standard; heavy duty driving/steer type.

Suspension

Front axle — Bolted to frame.

Rear axle — Spring rear suspension provides 4 wheel traction on rough terrain. Equipped with manual hydraulic rear oscillation lockout for picking on tires.

Tires

Front and rear — Standard 14.0 x 24 (20 ply).

Optional — 17.5 x 25 (20 ply).



Brakes

Service — Air over hydraulic brakes on all 4 wheels. 17" x 4" (0.43 m x 0.10 m) drum brakes on each wheel.

Parking — Spring applied, air released; cab controlled, mounted on front axle.

Steering — Hydraulic two wheel, four wheel, and "crab" steering controlled from operators cab.

Transmission — Power shift transmission, 6 speeds forward and 6 reverse.

Miscellaneous standard equipment — Hook block tie down, pintle hook-rear, fenders, 12-volt start, tool storage box, back-up alarm, horn, cab heater, defroster, wipers, rear view mirrors -both side, travel lights, lifting lugs, fire extinguisher.

Optional chassis equipment — Engine cover side doors, front winch (hydraulic).

Travel Speeds and Gradeability

Engine	Tires	Maximum Speed		Gradeability at stall	Maximum tractive effort at stall		Gradeability at 1.0 m.p.h. (1.61 km/h)	Maximum tractive effort at 1.0 m.p.h. (1.61 km/h)	
		m.p.h.	Km/h		pounds	kilograms		pounds	kilograms
GM 3-53T	14.0x24	25.6	41.19	79%	28,650	12 892	45%	19,280	8 676
	17.5x25	25.5	41.03	75%	28,370	12 766	44%	19,180	8 631
ISUZU 6BD1*	14.0x24	29.1	46.82	82%	29,340	13 203	44%	19,050	8 572
	17.5x25	28.9	46.50	78%	29,060	13 077	43%	18,960	8 532

*Optional equipment

ENGINE	GM3-53T	ISUZU 6BD1*
Cylinders - cycle	3 - 2	6 - 4
Bore	3-7/8" (98.43 mm)	4 in. (101.60 mm)
Stroke	4-1/2" (114.30 mm)	4-5/8" (117.48 mm)
Displacement	159 cu. in. (2 606 cm ³)	353 cu. in. (5785 cm ³)
Maximum Brake h.p.	131 @ 2500 rpm	132 @ 2800 rpm
Peak Torque	312 ft. lbs. (427.14 J)	268 ft. lbs. (363.41 J)
Electric System	12 v neg. ground	12 v neg. ground
Fuel Cap.	53 gallons (200.60 L)	53 gallons (200.60 L)
Alternator	42 amp	50 amp
Crankcase Cap.	3.5 gallons (13.2 L)	4.5 gallons (17.0 L)
Air Compressor	14.5 cfm. (.41 m ³ /m)	7.6 cfm (.22 m ³ /m)

*Optional equipment

Axle loads 3-section boom

Machine with standard 25'-60' (7.62-18.29 m) 3-section boom, enclosed cab, 385' (118 m) 1 1/2" (14 mm) wire rope, 4x4x4 carrier with GM 3-53T engine, 14.0x24 tires, counterweight, fenders, and hook block.	G. V. W.		Upper Facing Front				Upper facing rear			
			Front axle		Rear axle		Front axle		Rear axle	
	Lbs.	Kg.	Lbs.	Kg.	Lbs.	Kg.	Lbs.	Kg.	Lbs.	Kg.
	44,887	20 357	22,233	10 083	22,654	10 274	17,794	8 070	27,093	12 287
Engine cover side doors	+ 79	+ 36	- 13	- 6	+ 93	+ 42	- 13	- 6	+ 93	+ 42
20' lattice fly	+ 507	+ 230	+ 915	+ 415	- 408	- 185	- 426	- 193	+ 933	+ 423
20' A-frame jib	+ 736	+ 334	+ 1142	+ 518	- 428	- 194	- 452	- 205	+ 1188	+ 539
17.5 x 25 tires	+ 988	+ 448	+ 463	+ 210	+ 525	+ 238	+ 463	+ 210	+ 525	+ 238

① Adjust gross vehicle weight and axle loading according to components weight.

GENERAL INFORMATION ONLY



We are constantly improving our products and therefore reserve the right to change designs and specifications.

FMC Corporation Construction Equipment Group Lexington, Kentucky 40512

Link-Belt® cranes/excavators manufactured in: Cedar Rapids, Iowa • Lexington & Bowling Green, Ky. • Woodstock, Ontario, Canada • Milan, Italy • Queretaro, Mexico & Nagoya, Japan (under license).