

1870CP SIDE VIEW DIAGRAM

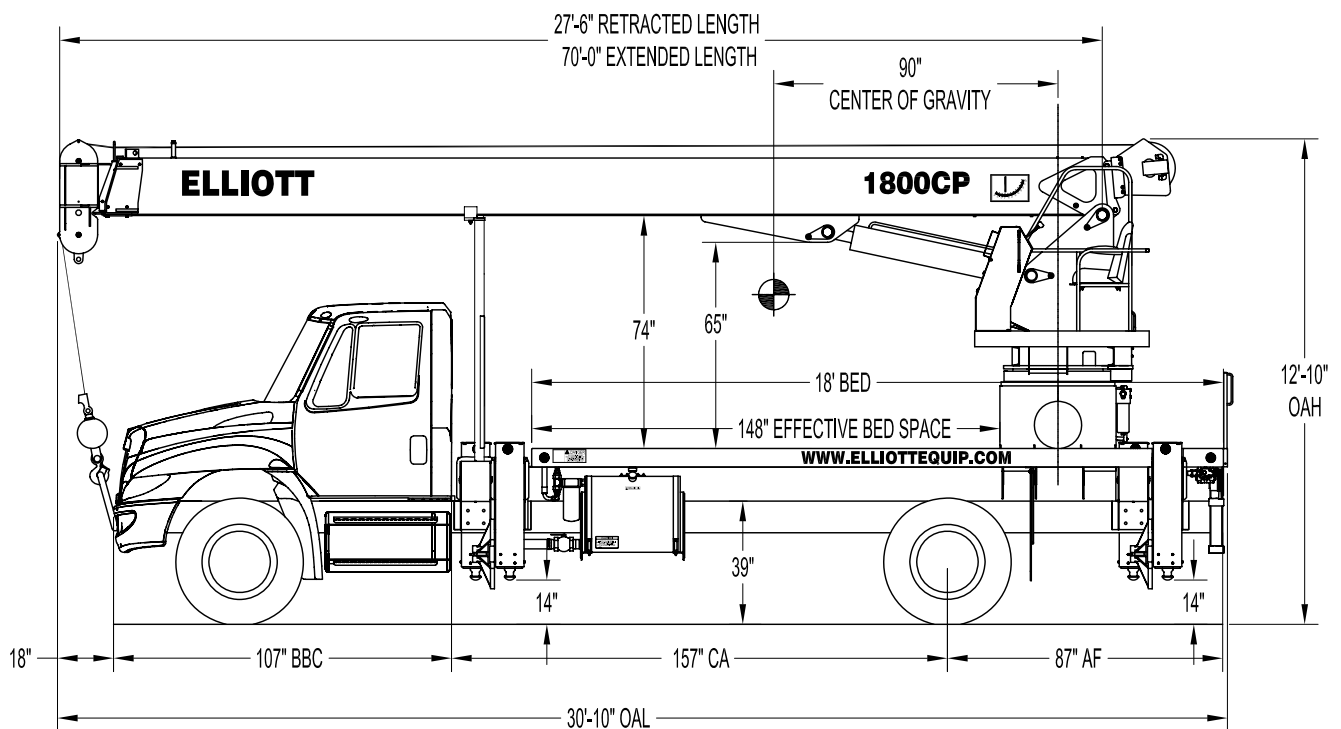

- **Maximum Vertical Reach** 120'/36.6 m
- **Working Area** 360 Degrees
- **Lifting Capacity** 36,000 lbs/16,329 kg
- **Boom Length** 70'/21.3 m
- **Crane Weight (Dry)** 16,235 lbs/7,364 kg
- **Jib Lengths** 23', 23-40'/7 m, 7-12 m
- **Winch Bare Drum Pull** 12,800 lbs/5,806 kg

- **Powered Boom Sections** 3
- **Overall Height** 12'10"/3.9 m
- **Operator Controls** Rotating Single Seat
- **Outrigger Type Front** Out-Down
- **Outrigger Spread Front** 17'6"/5.3 m
- **Outrigger Type Rear** Out-Down
- **Outrigger Spread Rear** 17'6"/5.3 m

TECHNICAL SPECIFICATIONS

Crane Capacity: 36,000 lbs at five feet load radius.

Maximum Tip Height: 80' height (120' with optional 40' jib)

Control Console: Rotating single seat control station on street side of crane equipped with four single axis control levers for the main crane controls and two grip strut steps for access. Operator station includes adjustable operator seat, LMI display, bubble level gauge, engine start/stop switch, signal horn button, variable speed foot throttle, lifting capacity chart, range diagram chart, boom angle indicator, system pressure gauge, 12V DC power source, and cup holder. Outrigger controls mounted at rear under each corner of bed.

Boom: Three-section fully proportional, high strength steel plated rectangular tube sections. A maximum boom tip height of 80' mounted on a truck. The boom nose contains one floating upper sheave and two lower sheaves. Assembly includes heavy-duty cylinder fittings, pivot pins, and replaceable wear pads.

Winch: Mounted at the base of the boom for a long fleet angle and flat level spooling of cable. Winch is driven by a planetary reducer and powered by a hydraulic motor. Burst-of-speed winch provides increased line speed. The winch brake is spring applied, pressure release design. Supplied with 275' of 9/16" wire rope with a single line pull of 9,600 pounds, and a downhaul ball with swivel hook for single part line.

Load Moment Indicator System:

System senses hoist cylinder pressures, boom length and boom angle with hydraulic function lockout. The display console is equipped with a bar graph showing crane utilization, boom angle or boom length, a mode select controls for main boom and jib operation, and an anti-two block with an audio/visual warning and shut-off functions to limit hook-boom point contact.

Outriggers: Two sets of out and down main outriggers with a 17'6" span, ball-socket removable aluminum outrigger pads and independent outrigger controls.

Frame: Full length, all welded rigid 4-plate design sub-frame. Sub-frame allows for bolt-on addition of 18' bed.

Turret: Reverse offset turret is one-piece weldment. Turret rotates on large diameter ball bearing.

Rotation: Hydraulic motor drives turret through double reduction planetary swing drive for continuous rotation. The swing drive system has a spring applied, pressure release brake.

Lift: One double-acting long stroke cylinder provides smooth and stable boom elevation. Holding valve prevents boom from falling in event of hose failure.

Boom Extension: Incorporates a single double-acting hydraulic extension cylinder, attached to the largest boom section, with a proportional cable extension system driving the outermost section.

Hoses: All high pressure hoses are wire braid reinforced with a minimum safety factor of 4 to 1.

Cylinders: All cylinders use microhoned cylinder tubing, chrome shafts, top grade packing and protective rod wipers. Cylinder-mounted holding valves provided on all load-holding cylinders.

Hydraulic System: Equipped with cable-shift PTO, three-section gear pump, SAE O-ring face seals on pressure lines, and a 10-micron return line filter. The control valve distributes all flow to hoist system, swing circuit, and other crane functions. System is open center type.

Oil Tank Capacity: 70 gallon mounted to truck frame on roadside.

Cab Equipment: PTO cable or switch with indicator lights installed in truck cab. U/L approved 5:BC dry chemical

fire extinguisher installed in truck cab.

Operators Manual & Video: Two CD copies and one hard copy of operation, maintenance, safety and parts manual provided with each unit. Operational and safety video provided at delivery.

Installation: Unit installed on chassis, painted, system and tank filled with oil, tested, inspected, and ready to operate.

Standard Paint: Paint turret and boom white, outriggers red, and bed and boxes black.

Bumper: Bureau of Motor Carrier Safety rear bumper.

Weight: Approximately 16,235 lbs. with 18' steel-floor bed less truck.

Truck Chassis Required: Approx. 157" C.A. RBM 1,463,000 in-lb. per rail, 13,000 lb. front axle and 33,000 lb. GVWR required. Trucks must have 12V electrical system with high capacity alternator, cab clearance stop/tail/backup lights, and I.D. lamps. Recommended GVWR is minimum for BoomTruck with flatbed only. Contact factory when additional equipment is to be added.

Options:

23' Fixed or 40' Telescopic Jib.

Radio Remote Controls.

1 or 2 Person Gravity Leveled Steel Basket.

Rotation Resistant Wire Rope.

Hydraulic Tool Circuits on Bed.

Much More...

Elliott Equipment Company reserves the right to change the specification of any unit at any time without prior notice. This brochure is only a statement of general specifications on the date of this publication. For more detailed info on specific Elliott trucks go to www.elliottequip.com

MAXIMUM LIFTING AND RANGE CAPABILITIES

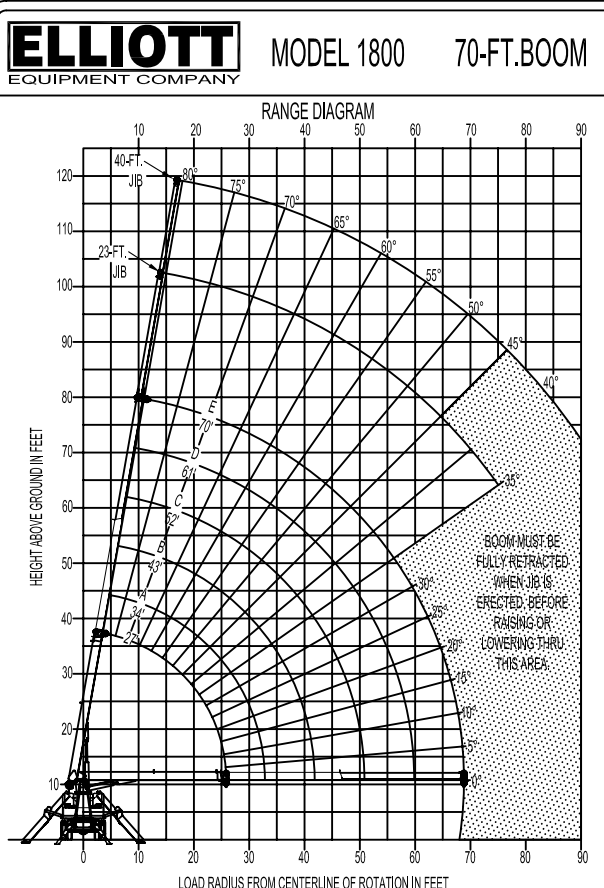

ALLOWABLE LINE PULL				NOTICE
1-PART LINE	2-PART LINE	3-PART LINE	4-PART LINE	
				<ul style="list-style-type: none"> - DO NOT DEADHEAD LINE BLOCK AGAINST BOOM TIP WHEN EXTENDING BOOM - KEEP AT LEAST 5 WRAPS OF LOADLINE ON THE WINCH DRUM AT ALL TIMES - USE ONLY 9/16" DIAMETER WIRE ROPE, AS SPECIFIED BELOW, WITH THE PROPER BREAKING STRENGTHS LISTED - ANTI-TWO-BLOCK SYSTEM MUST BE IN GOOD OPERATING CONDITION BEFORE OPERATING CRANE. SEE OPERATION & SAFETY MANUAL - MAXIMUM CAPACITY WITH "BURST OF SPEED" IS 500 LBS.
9600-LBS.	19200-LBS.	28800-LBS.	36000-LBS.	
9060-LBS.	18120-LBS.	27180-LBS.	36000-LBS.	
7680-LBS.	15360-LBS.	23040-LBS.	30720-LBS.	

DEDUCTIONS FROM RATED LOADS FOR HANDLING DEVICES SUPPLIED BY ELLIOTT EQUIPMENT CO.
 OVERHAUL BALL ----- SEE OVERHAUL BALL MFGR. NAMEPLATE
 LOAD BLOCK ----- SEE BLOCK MFGR. NAMEPLATE
 SWING AROUND JIB ----- SEE LOAD RATING CHART

WARNING:
 LIFTING OFF THE MAIN BOOM WHILE JIB IS ERECTED IS NOT INTENDED OR APPROVED

MAIN BOOM LOAD RATINGS											JIB LOAD RATINGS									
LOAD RATINGS IN LBS., WITH OUTRIGGERS AND STABILIZERS EXTENDED											LOAD RATINGS IN LBS., WITH OUTRIGGERS AND STABILIZERS EXTENDED									
LOAD RADIUS IN FEET	LOADED BOOM ANGLE	A					B				C	D	E	23-FT FIXED LENGTH JIB		23-40 FT EXTENDABLE JIB				
		27-FT	34-FT	43-FT	52-FT	61-FT	70-FT	LOADED BOOM ANGLE	23-FT JIB	LOADED BOOM ANGLE	23-FT JIB RETRACTED	LOADED BOOM ANGLE	40-FT JIB EXTENDED	LOADED BOOM ANGLE	23-FT JIB	LOADED BOOM ANGLE	23-FT JIB	LOADED BOOM ANGLE	40-FT JIB EXTENDED	
5	79	36000																		
10	68	21300	73	19500	77	16500	80	15000												
15	56	15200	64	14500	70	13500	75	12000	78	10500	80	9600								
20	41	11500	54	11100	63	10000	69	9000	73	8000	76	7300								
25	19	8600	43	8500	55	8000	62	7200	68	6500	71	5800								
30			27	6750	47	6400	56	5900	63	5400	67	4900								
35					36	5000	49	4700	56	4400	62	4200								
40					20	4200	41	4100	50	3900	56	3700								
45							30	3500	43	3400	51	3200								
50							14	2800	36	2800	45	2700								
55									26	2400	39	2300								
60											32	1900								
65											22	1500								
0	0	6000	0	4200	0	3000	0	1900	0	1300	0	1000								
		340		270		210		170		150		130								
		530		420		330		270		230		200								

- WARNING
1. THE OPERATOR MUST READ AND UNDERSTAND ALL DECALS IN ADDITION TO THE OPERATION AND SAFETY MANUAL BEFORE OPERATING THIS CRANE.
 2. POSITIONING OR OPERATION OF CRANE BEYOND AREAS SHOWN ON THIS CHART IS NOT INTENDED OR APPROVED EXCEPT WHERE SPECIFIED IN THE OPERATION AND SAFETY MANUAL.
 3. LOADED BOOM ANGLES AT SPECIFIED BOOM LENGTHS GIVE ONLY AN APPROXIMATION OF THE OPERATING RADIUS. THE BOOM ANGLE BEFORE APPLYING A LOAD SHOULD BE GREATER TO ACCOUNT FOR DEFLECTION. DO NOT EXCEED THE OPERATING RADIUS FOR A BOOM LENGTH AND LOAD RATING.
 4. THE JIB LOAD RATING CHART IS BASED ON THE LOADED BOOM ANGLES OF THE MAIN BOOM AND NOT THE LOAD RADIUS. DO NOT EXCEED JIB LOAD RATINGS AT REDUCED BOOM LENGTHS.
 5. FOR BOOM ANGLES NOT SHOWN ON JIB LOAD RATING CHART, USE RATING OF NEXT LOWER BOOM ANGLE.
 6. FOR BOOM LENGTHS NOT SHOWN, USE THE RATING OF NEXT LONGER BOOM LENGTH, FOR RADII NOT SHOWN, USE RATING OF NEXT LONGER RADIUS.
 7. CRANE LOAD RATINGS ON OUTRIGGERS AND STABILIZERS ARE BASED ON FREELY SUSPENDED LOADS WITH THE MACHINE LEVELED AND STANDING ON A FIRM UNIFORM SUPPORTING SURFACE. NO ATTEMPT SHALL BE MADE TO MOVE A LOAD HORIZONTALLY ON THE GROUND IN ANY DIRECTION.
 8. PRACTICAL WORKING LOADS DEPEND ON THE SUPPORTING SURFACE, WIND, AND OTHER FACTORS AFFECTING STABILITY SUCH AS HAZARDOUS SURROUNDINGS, EXPERIENCE OF PERSONNEL, AND PROPER HANDLING, ALL OF WHICH MUST BE TAKEN INTO ACCOUNT BY THE OPERATOR.
 9. THE MAXIMUM LOAD WHICH MAY BE TELESCOPED IS LIMITED BY HYDRAULIC PRESSURE, BOOM ANGLE, AND BOOM LUBRICATION. IT IS SAFE TO ATTEMPT TO TELESCOPE ANY LOAD WITHIN THE LIMITS OF THE LOAD RATING CHART. BOOM MUST BE FULLY RETRACTED AGAINST THE BOOM STOPS AT ALL TIMES WHEN LIFTING MINIMUM BOOM LENGTH CAPACITY LOADS.
 10. IF ANY OPERATIONAL AID SUCH AS ANTI-2-BLOCK, OVERLOAD SYSTEM OR LEVELING INDICATOR IS MALFUNCTIONING OR INOPERATIVE, DISCONTINUE USE IMMEDIATELY AND CONTACT A QUALIFIED REPAIR FACILITY.
 11. CAPACITY INDICATING LIMITING DEVICES SHOULD NOT BE RELIED UPON TO REPLACE THE USE OF CAPACITY CHARTS AND PROPER OPERATING PROCEDURES.

- INFORMATION
1. DEDUCTIONS MUST BE MADE FROM RATED CAPACITIES FOR STOWED JIB, OPTIONAL ATTACHMENTS, HOOKS, LOAD BLOCKS (SEE DEDUCTION CHART), WEIGHTS OF SLINGS AND ALL OTHER LOAD HANDLING DEVICES SHALL BE CONSIDERED A PART OF THE LOAD.
 2. CRANE LOAD RATINGS WITH OUTRIGGERS ARE BASED ON OUTRIGGERS AND STABILIZERS EXTENDED AND SET WITH ALL LOAD REMOVED FROM CARRIER WHEELS.
 3. LOAD RATINGS ABOVE THE BOLD LINE ARE STRUCTURALLY LIMITED AND DO NOT EXCEED 85% OF TIPPING.
- DEFINITIONS
1. OPERATING RADIUS IS THE HORIZONTAL DISTANCE FROM THE CENTER OF ROTATION TO THE CENTER OF THE VERTICAL HOIST LINE OR TACKLE WITH A LOAD APPLIED.
 2. LOADED BOOM ANGLES, SHOWN ABOVE, ARE THE INCLUDED ANGLE BETWEEN THE HORIZONTAL AND LONGITUDINAL AXIS OF THE BOOM BASE AFTER LIFTING RATED LOAD AT THE RATED RADIUS.

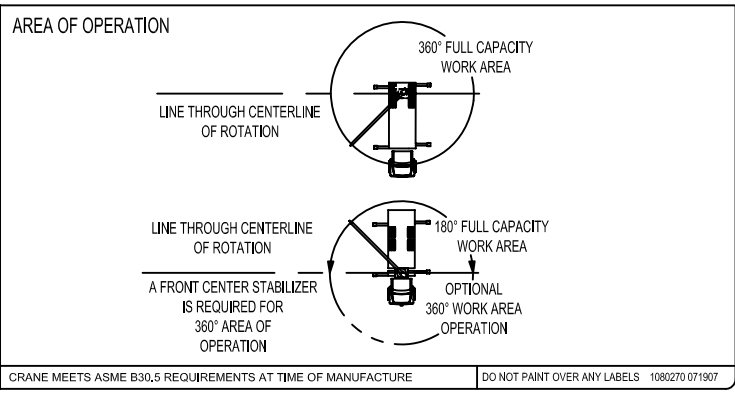

CHASSIS SPECIFICATIONS

	1870CP BoomTruck
Wheelbase (WB)	224" / 569 cm
Cab to Axle (CA)	157" / 399 cm
Cab to End of Frame (EOF)	247" / 627 cm
Frame Section Modulus	13.3 in3-110,000 psi
Front Axle Gross Weight Rating	13,000 lb / 5,896 kg
Rear Axle Gross Weight Rating	20,000 lb / 9,072 kg
Integral Front Frame Rails	Not Applicable

Chassis data is minimum general requirements-not for engineering.
 Actual dimensions and truck data will depend on truck selection and axle configuration.
 *Minimum chassis weight is required to meet 85% stability requirements.

OPTIONS



Radio Remote Control

Interference protected radio remotes let you get closer to your work and have full control over your machine.



Pin-On Jib Attachments

One piece & two piece telescoping or fixed jibs that stow on the side of the boom for easy placement while on the worksite.



Hydraulic Oil Cooler

Add a bed-mounted hydraulic oil cooler and fan to assist with high duty cycle job applications. A "must" for hot weather environments



Custom Paint

Choose from a wide list of high quality paint applications including Elliott's standard white or red paint, metallic paints, or multiple colors.



Tool Boxes

Optional tool boxes and bed storage can accommodate any storage need for tools, work materials and more.

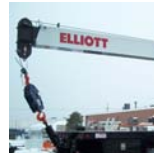

Hook Block for Multi-Part Line

Elliott can install a 2-3 part hook block or a 4 part-hook block to improve lifting capabilities. The block can be stored at the rear of the bed.



Gravity Levelled Basket

Elliott's pin-on work platform pins onto the boom for easy installation and removal. Gravity leveling and mechanical rotation makes it a great accessory for any worksite.



Body Mounted Hose Reels and Circuits

Let us work with you to customize your tool compatibility by adding hose reels or hydraulic circuits to the crane bed.