

7530

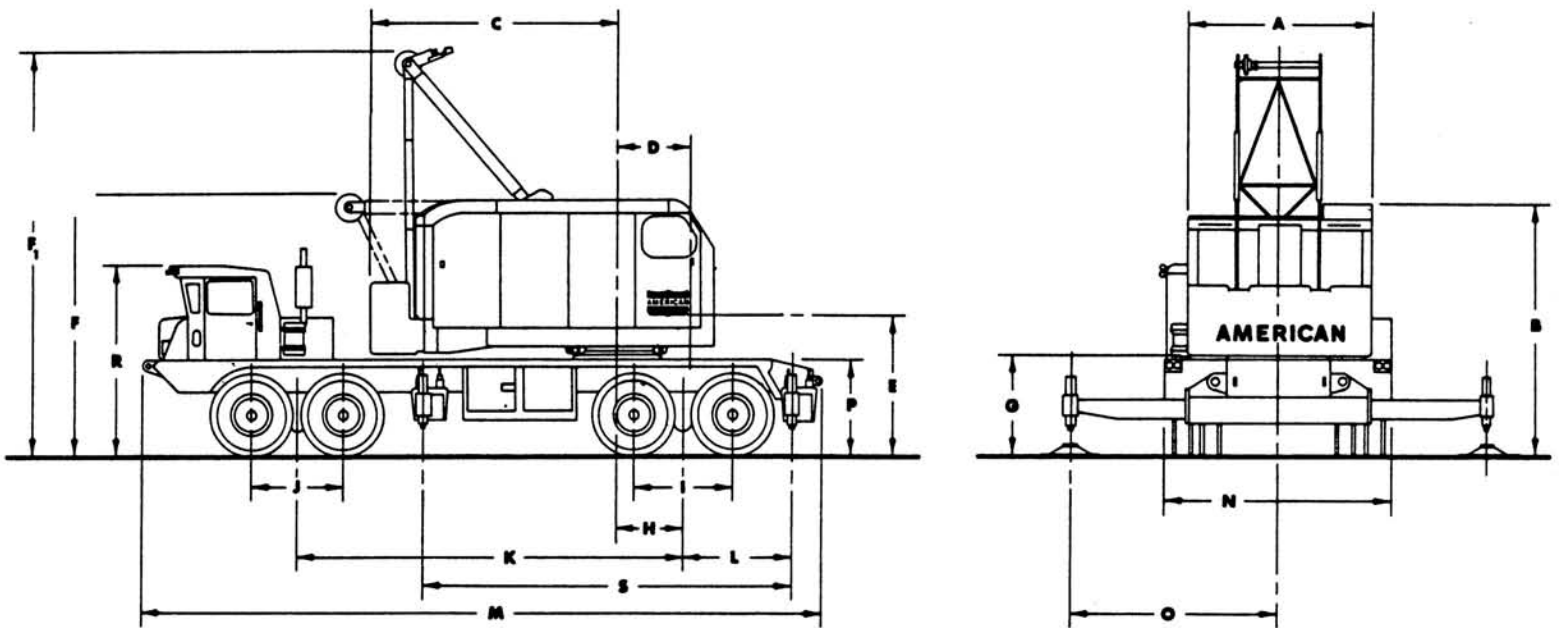

CARRIER SPECIFICATIONS



GENERAL DIMENSIONS

A. Width of cab.....	10'6"	K. Centerline of rear bogie to centerline of front bogie	19'10"
B. Height to top of cab	12'11 $\frac{1}{4}$ "	L. Centerline of rear bogie to centerline of rear outrigger.....	6'5 $\frac{1}{2}$ "
C. Tail Swing.....	14'1 $\frac{1}{2}$ "	M. Overall length.....	35'8"
D. Centerline of rotation to centerline of boom foot	4'1 $\frac{1}{2}$ "	N. Overall width.....	11'0"
E. Ground to centerline boom foot.....	6'9 $\frac{1}{4}$ "	O. Outriggers extended w/hydraulic outriggers.....	11'0"
F. Height over A-Frame (lowered).....	13'5"	P. Height over mounting plate.....	4'5"
F'. Height over A-Frame (raised).....	21'9 $\frac{1}{2}$ "	R. Height over carrier cab	9'3"
Ground to bottom of counterweight	5'2"	S. Centerline of rear outrigger to centerline of front outrigger.....	20'4 $\frac{1}{2}$ "
H. Centerline of rotation to centerline of rear bogie	3'6"	Turning radius.....	.66'-0"
I. Distance between rear axles	5'4"	Clearance (under rear equalizing beam).....	7 $\frac{3}{4}$ "
J. Distance between front axles	5'0"	Clearance (under rear differential).....	15 $\frac{1}{4}$ "

7530 TRAVELING WEIGHTS

IN POUNDS

X = IN PLACE
O = REMOVED

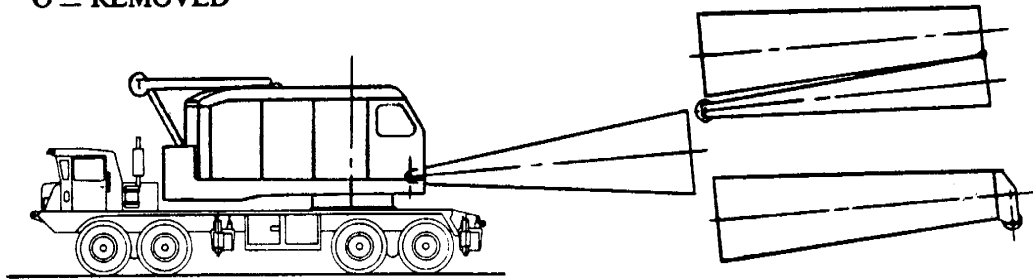

TAPERED TIP
BOOM FOLDED

HAMMERHEAD TIP

Boom Rearward

TAPER TIP FOLDED	BLOCK	OUTER BOOM HAMMERHEAD	INNER BOOM	COUNTERWT.	FRONT OUTRIGGER	REAR OUTRIGGER	FRONT TANDEM	REAR TANDEM	GROSS WEIGHTS
O	X	X	X	X	X	X	58,630	101,680	160,310
O	O	X	X	X	X	X	63,620	94,250	157,870
X	O	O	X	X	X	X	64,090	94,530	158,620
O	X	X	X	O	X	X	30,880	95,430	126,310
O	O	X	X	O	X	X	35,870	88,000	123,870
X	O	O	X	O	X	X	36,340	88,280	124,620
O	X	X	X	O	O	X	25,670	93,040	118,710
O	O	X	X	O	O	X	30,660	85,600	116,260
X	O	O	X	O	O	X	31,130	85,880	117,010
O	X	X	X	O	X	O	33,330	85,370	118,700
O	O	X	X	O	X	O	38,320	77,940	116,260
X	O	O	X	O	X	O	38,800	78,220	117,020
O	X	X	X	O	O	O	28,120	82,980	111,100
O	O	X	X	O	O	O	33,110	75,540	108,650
X	O	O	X	O	O	O	33,590	75,820	109,410
O	O	O	X	X	X	X	70,440	83,740	154,180
O	O	O	X	O	X	X	42,690	77,480	120,170
O	O	O	X	O	O	X	37,480	75,090	112,570
O	O	O	X	O	X	O	45,150	67,430	112,580
O	O	O	X	O	O	O	39,940	65,030	104,970
O	O	O	O	X	X	X	71,430	80,200	151,630
O	O	O	O	O	X	X	43,680	73,950	117,630
O	O	O	O	O	O	X	38,470	71,550	110,020
O	O	O	O	O	X	O	46,130	63,890	110,020
O	O	O	O	O	O	O	40,920	61,490	102,420
Carrier with bullgear and outriggers — less upper							25,970	39,750	65,720

NOTE: Because of variable manufacturing tolerances a variance of $\pm 3\%$ should be allowed on the above weights.

1:24/2/9/72

1:17/2/9/72

BOOM ANGLE DIAGRAM

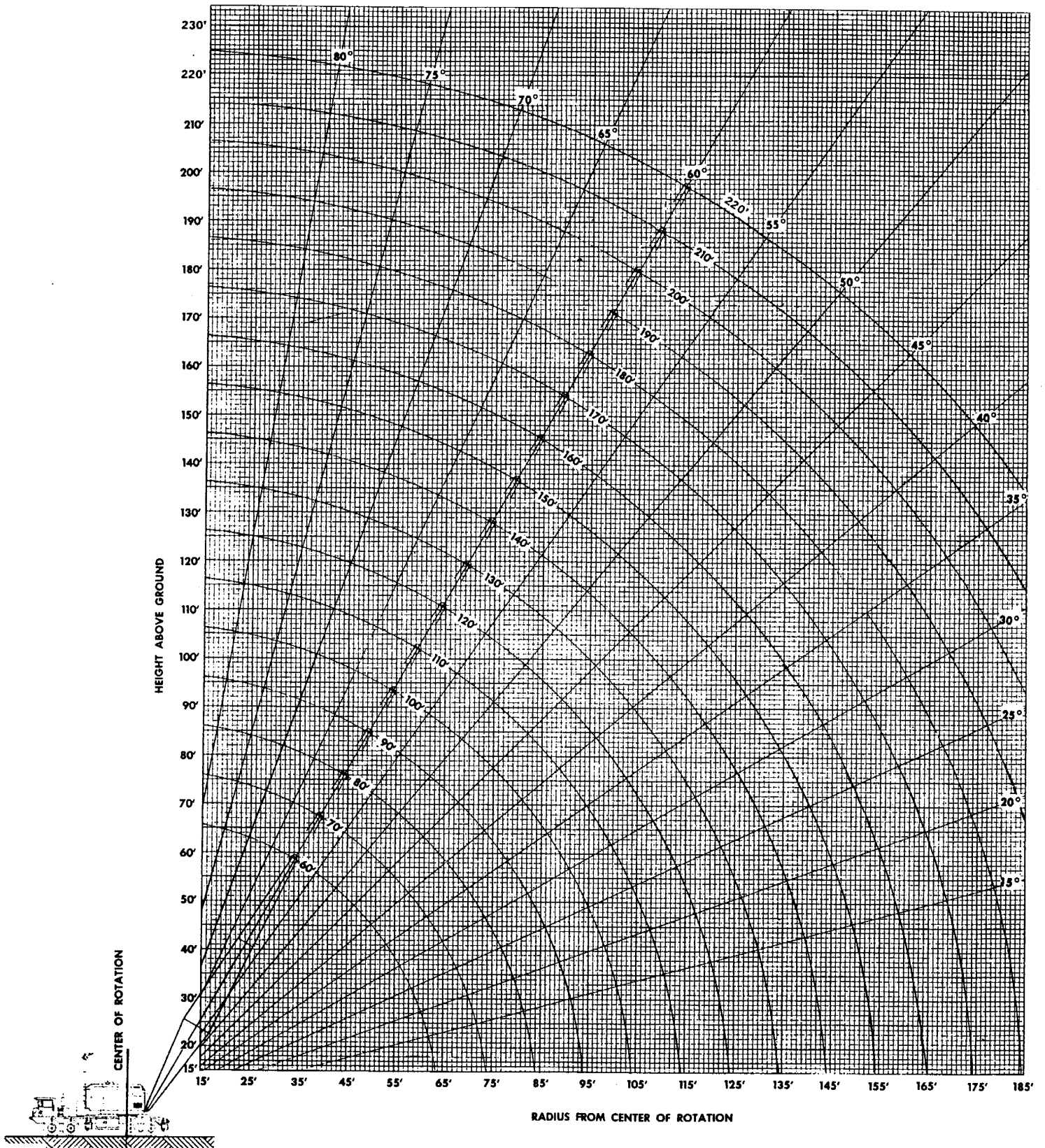

AMERICAN MODEL 7530 TRUCK CRANE WORKING RANGES



700 SERIES MODEL 7530 TRUCK CRANE

LIFT RATINGS

With 59H Tubular Hammerhead Boom and "K-F-L-M" Counterweight (34,000 lbs.)

Boom Length In Feet	Radius In Feet	Boom Angle Degrees	Outriggers Free		Outriggers Set		Ft. From Boom Pt. to Ground	Min. Load Line
			Over Side	Over Rear	Over Side	Over Rear		
40 foot	11	82.8	-	91090	250000	250000	47	10
	12	81.3	-	87730	250000	250000	47	10
	15	77.0	-	78920	205060	205060	46	8
	20	69.6	-	67160	145190	145190	45	6
	25	61.7	31390	50680	111910	111910	43	5
	30	53.1	26050	40390	90710	90710	39	4
	35	43.3	22060	33350	73810	74420	35	3
	40	30.9	18960	28220	60380	61380	28	3
50 foot	13	81.9	-	84120	238730	238730	57	10
	15	79.6	-	78460	205030	205030	57	8
	20	73.8	-	67040	145120	145120	55	6
	25	67.7	31160	50630	111830	111830	54	5
	30	61.3	25840	40330	90630	90630	51	4
	35	54.5	21880	33300	73910	74490	48	3
	40	47.0	18810	28170	60470	61440	44	3
	50	27.4	14330	21180	43860	45050	30	2
60 foot	14	82.3	-	80690	221500	221500	67	9
	15	81.3	-	77970	204910	204910	67	8
	20	76.5	38380	66580	144970	144970	66	6
	25	71.6	30860	50500	111670	111670	64	5
	30	66.5	25560	40200	90460	90460	62	4
	35	61.1	21610	33160	73920	74480	60	3
	40	55.5	18560	28040	60450	61410	57	3
	50	42.6	14120	21070	43850	45010	48	2
60	24.8	11030	16530	33960	35110	32	2	
70 foot	15	82.6	-	77450	204750	204750	77	8
	20	78.5	38040	66100	144780	144780	76	6
	25	74.3	30540	50340	111460	111460	75	5
	30	70.0	25240	40030	90250	90250	73	4
	35	65.6	21310	32990	73880	74410	71	3
	40	61.0	18270	27870	60390	61320	69	3
	50	51.0	13850	20910	43760	44920	62	2
	60	39.3	10800	16380	33890	35030	52	2
70	22.9	8530	13180	27320	28390	34	2	
80 foot	16	82.8	-	74460	189050	189050	87	8
	20	79.9	37730	65680	144600	144600	86	6
	25	76.3	30240	50190	111270	111270	85	5
	30	72.6	24960	39870	90050	90050	84	4
	35	68.8	21030	32830	73830	74340	82	3
	40	64.9	18000	27700	60320	61240	80	3
	50	56.6	13600	20750	43670	44810	74	2
	60	47.5	10560	16230	33790	34920	66	2
70	36.6	8330	13050	27230	28300	55	2	
80	21.3	6580	10670	22540	23530	36	1	
90 foot	17	83.0	43570	71550	175420	175420	97	7
	20	81.0	37360	65180	144370	144370	96	6
	25	77.8	29880	49990	111020	111020	95	5
	30	74.5	24610	39670	89790	89790	94	4
	35	71.2	20690	32610	73740	74230	93	3
	40	67.8	17660	27490	60200	61100	91	3
	50	60.7	13280	20530	43520	44660	86	2
	60	53.1	10260	16020	33630	34750	79	2
70	44.6	8030	12850	27080	28130	70	2	
80	34.4	6320	10490	22400	23380	58	1	
90	20.0	4940	8640	18880	19780	38	1	
100 foot	19	82.5	38860	66670	153230	153230	107	6
	20	81.9	36970	64670	144120	144120	107	6
	25	79.0	29500	49780	110760	110760	106	5
	30	76.1	24240	39450	89520	89520	105	4
	35	73.2	20330	32390	73640	74100	103	3

Boom Length In Feet	Radius In Feet	Boom Angle Degrees	Outriggers Free		Outriggers Set		Ft. From Boom Pt. to Ground	Min. Load Line	
			Over Side	Over Rear	Over Side	Over Rear			
100 foot cont.	40	70.1	17310	27260	60070	60950	102	3	
	50	63.9	12940	20300	43360	44480	97	2	
	60	57.3	9920	15790	33460	34570	92	2	
	70	50.2	7710	12620	26900	27940	84	2	
	80	42.1	6020	10270	22220	23190	74	1	
	90	32.5	4660	8440	18710	19610	61	1	
	100	18.9	3540	6970	15970	16800	39	1	
	110 foot	20	82.7	36580	64160	143870	143870	117	6
		25	80.0	29120	49560	110490	110490	116	5
		30	77.4	23870	39220	89240	89240	115	4
35		74.7	19960	32150	73520	73960	114	3	
40		72.0	16950	27020	59930	60800	112	3	
50		66.4	12590	20060	43190	44300	108	2	
60		60.6	9580	15540	33270	34370	103	2	
70		54.4	7380	12380	26700	27740	97	2	
80		47.7	5690	10030	22020	22990	89	1	
90		40.1	4350	8210	18520	19410	78	1	
100		31.0	3260	6760	15790	16610	64	1	
110	18.0	2330	5560	13580	14350	41	1		
120 foot	21	82.8	34500	61830	135520	135520	127	6	
	25	80.9	28780	49370	110240	110240	126	5	
	30	78.5	23530	39010	88980	88980	125	4	
	35	76.0	19630	31940	73410	73830	124	3	
	40	73.5	16620	26800	59790	60640	123	3	
	50	68.5	12270	19830	43030	44120	119	2	
	60	63.3	9270	15320	33090	34190	115	2	
	70	57.8	7080	12150	26520	27550	109	2	
	80	51.9	5400	9810	21830	22790	102	1	
	90	45.5	4060	8000	18330	19220	93	1	
	100	38.3	2980	6550	15600	16420	82	1	
	110	29.6	2070	5360	13410	14180	66	1	
120	17.2	1280	4366	11600	12310	42	1		
130 foot	22	82.9	32520	58060	127970	127970	137	5	
	25	81.6	28400	49150	109970	109970	136	5	
	30	79.4	23150	38780	88700	88700	135	4	
	35	77.1	19260	31700	73280	73690	134	3	
	40	74.8	16250	26560	59640	60480	133	3	
	50	70.2	11910	19580	42850	43930	130	2	
	60	65.5	8920	15070	32890	33980	126	2	
	70	60.5	6730	11900	26310	27330	121	2	
	80	55.3	5060	9560	21620	22570	114	1	
	90	49.7	3730	7750	18110	18990	107	1	
	100	43.6	2650	6300	15380	16200	97	1	
	110	36.7	1750	5120	13200	13960	85	1	
	120	28.4	990	4130	11400	12110	69	1	
130	16.5	-	3280	9890	10550	44	1		
140 foot	24	82.6	-	-	111160	111160	146	5	
	25	82.2	-	-	109690	109690	146	5	
	30	80.1	-	-	88400	88400	145	4	
	35	78.0	-	-	73160	73540	144	3	
	40	75.9	-	-	59490	60300	143	3	
	50	71.7	-	-	42660	43730	140	2	
	60	67.3	-	-	32690	33770	137	2	
	70	62.8	-	-	26090	27110	132	2	
	80	58.1	-	-	21400	22350	126	1	
	90	53.1	-	-	17890	18760	119	1	
	100	47.8	-	-	15160	15970	111	1	
	110	41.9	-	-	12970	13730	101	1	
	120	35.3	-	-	11180	11880	88	1	
	130	27.3	-	-	9680	10340	71	1	
140	15.9	-	-	8390	9010	45	1		

(Continued)

LIFT RATINGS (cont.)

With 59H Tubular Hammerhead Boom

Boom Length In Feet	Radius In Feet	Boom Angle Degrees	Outriggers Free		Outriggers Set		Ft. From Boom Pt. to Ground	Min. Load Line
			Over Side	Over Rear	Over Side	Over Rear		
150 feet	25	82.7	—	—	96520	96520	156	4
	30	80.8	—	—	88110	88110	156	4
	35	78.8	—	—	73020	73360	155	3
	40	76.9	—	—	59330	60130	154	3
	50	72.9	—	—	42470	43530	151	2
	60	68.9	—	—	32480	33550	147	2
	70	64.8	—	—	25870	26880	143	2
	80	60.4	—	—	21170	22110	138	1
	90	55.9	—	—	17660	18530	132	1
	100	51.2	—	—	14920	15730	124	1
	110	46.1	—	—	12740	13490	115	1
	120	40.4	—	—	10950	11650	105	1
	130	34.1	—	—	9450	10110	91	1
	140	26.3	—	—	8170	8790	74	1
	150	15.3	—	—	7070	7650	47	1

Boom Length In Feet	Radius In Feet	Boom Angle Degrees	Outriggers Free		Outriggers Set		Ft. From Boom Pt. to Ground	Min. Load Line
			Over Side	Over Rear	Over Side	Over Rear		
160 feet	26	82.8	—	—	85260	85260	166	4
	30	81.4	—	—	85260	85260	166	4
	35	79.6	—	—	72930	73110	165	3
	40	77.7	—	—	59210	59990	164	3
	50	74.0	—	—	42310	43360	161	2
	60	70.3	—	—	32300	33360	158	2
	70	66.4	—	—	25680	26680	154	2
	80	62.5	—	—	20970	21900	149	1
	90	58.3	—	—	17450	18310	144	1
	100	54.0	—	—	14710	15510	137	1
	110	49.4	—	—	12520	13270	129	1
	120	44.5	—	—	10730	11430	119	1
	130	39.1	—	—	9230	9890	108	1
	140	32.9	—	—	7960	8580	94	1
	150	25.5	—	—	6870	7440	76	1
160	14.8	—	—	5900	6450	48	1	

7530.07

LIFT RATINGS

With 59H Tubular Tapered Tip Boom and "K-F-L-M" Counterweight (34,000 lbs.)

Boom Length In Feet	Radius In Feet	Boom Angle Degrees	Outriggers Free		Outriggers Set		Ft. From Boom Pt. to Ground	Min. Load Line
			Over Side	Over Rear	Over Side	Over Rear		
60 feet	14	80.5	—	81560	153940	153940	66	6
	15	79.6	—	78850	153940	153940	66	6
	20	74.7	—	67510	143150	143150	65	6
	25	69.6	31740	51150	112350	112350	63	5
	30	64.5	26500	40930	91250	91250	61	4
	35	59.0	22590	33940	74650	75210	58	3
	40	53.3	19580	28860	61240	62200	55	3
70 feet	50	40.1	15210	21960	44720	45890	45	2
	60	21.4	12180	17480	34910	36060	29	2
	16	80.2	—	75780	153940	153940	76	6
	20	76.9	—	67010	143150	143150	75	6
	25	72.6	31390	50960	112090	112090	74	5
	30	68.3	26150	40730	90990	90990	72	4
	35	63.8	22260	33740	74570	75110	70	3
80 feet	40	59.2	19260	28660	61140	62080	67	3
	50	49.1	14900	21760	44590	45750	60	2
	60	37.0	11900	17290	34780	35920	49	2
	70	19.8	9680	14140	28270	29340	30	2
	17	80.7	—	72850	153940	153940	86	6
	20	78.6	38410	66490	143150	143150	85	6
	25	74.9	31000	50740	111810	111810	84	5
90 feet	30	71.1	25780	40510	90710	90710	82	4
	35	67.3	21900	33510	74460	74980	81	3
	40	63.4	18910	28430	61010	61930	78	3
	50	55.0	14570	21540	44440	45590	72	2
	60	45.7	11580	17070	34610	35750	64	2
	70	34.6	9380	13930	28100	29170	52	2
	80	18.5	7680	11590	23460	24440	32	1
100 feet	19	80.5	39870	67970	150730	150730	96	6
	20	79.8	38000	65970	143150	143150	95	6
	25	76.6	30610	50500	111510	111510	94	5
	30	73.3	25400	40270	90400	90400	93	4
	35	69.9	21530	33270	74330	74830	91	3
	40	66.5	18540	28190	60860	61770	89	3
	50	59.4	14220	21300	44260	45400	84	2
	60	51.6	11240	16830	34430	35550	77	2
	70	43.0	9060	13690	27910	28970	68	2
	80	32.5	7380	11360	23270	24250	55	1
90	17.4	6040	9550	19790	20690	34	1	
100 feet	20	80.9	37640	65510	143150	143150	106	6
	25	78.0	30260	50290	111240	111240	105	5
	30	75.0	25060	40050	90130	90130	103	4
	35	72.0	21200	33050	74210	74690	102	3
	40	69.0	18220	27970	60720	61610	100	3
	50	62.7	13900	21070	44100	45230	96	2
	60	56.0	10930	16610	34250	35370	90	2
	70	48.8	8760	13470	27740	28790	82	2

Boom Length In Feet	Radius In Feet	Boom Angle Degrees	Outriggers Free		Outriggers Set		Ft. From Boom Pt. to Ground	Min. Load Line
			Over Side	Over Rear	Over Side	Over Rear		
100 feet cont.	80	40.6	7090	11150	23090	24070	72	1
	90	30.8	5770	9350	19620	20520	58	1
	100	16.5	4680	7910	16900	17740	35	1
110 feet	22	80.6	33930	58850	128780	128780	115	6
	25	79.1	29850	50050	110920	110920	115	5
	30	76.4	24660	39800	89810	89810	114	4
	35	73.7	20810	32800	74060	74520	112	3
	40	71.0	17840	27710	60550	61430	111	3
	50	65.4	13540	20820	43910	45020	107	2
	60	59.5	10580	16350	34050	35160	102	2
	70	53.2	8410	13220	27520	28570	95	2
	80	46.4	6750	10900	22880	23850	86	1
	90	38.7	5440	9100	19400	20300	76	1
	100	29.4	4360	7670	16700	17520	61	1
110	15.7	3460	6500	14520	15290	37	1	
120 feet	23	81.0	32050	55370	121920	121920	125	5
	25	80.0	29440	49790	110590	110590	125	5
	30	77.5	24260	39540	89480	89480	124	4
	35	75.1	20410	32540	73910	74350	123	3
	40	72.6	17450	27450	60380	61240	121	3
	50	67.5	13160	20550	43710	44810	118	2
	60	62.2	10210	16080	33840	34940	113	2
	70	56.7	8050	12950	27300	28340	107	2
	80	50.8	6400	10630	22650	23610	100	1
	90	44.3	5090	8840	19170	20060	91	1
	100	37.0	4030	7420	16470	17290	79	1
	110	28.1	3140	6250	14300	15070	63	1
120	15.1	2380	5270	12520	13230	38	1	
130 feet	25	80.8	29020	49540	110270	110270	135	5
	30	78.5	23850	39280	89150	89150	134	4
	35	76.3	20020	32270	73750	74170	133	3
	40	74.0	17060	27180	60200	61040	132	3
	50	69.3	12780	20280	43500	44600	128	2
	60	64.5	9840	15810	33620	34710	124	2
	70	59.6	7680	12680	27070	28100	119	2
	80	54.3	6040	10360	22420	23370	112	1
	90	48.7	4740	8580	18940	19820	104	1
	100	42.5	3680	7150	16230	17050	95	1
	110	35.5	2800	5990	14070	14830	82	1
	120	27.0	2060	5020	12290	13000	66	1
	130	14.5	1410	4190	10800	11460	39	1
140 feet	27	80.6	—	—	100480	100480	145	4
	30	79.3	—	—	88850	88850	144	4
	35	77.3	—	—	73600	74000	143	3
	40	75.2	—	—	60020	60850	142	3
	50	70.9	—	—	43310	44390	139	2
	60	66.5	—	—	33410	34490	135	2
	70	61.9	—	—	26860	27880	130	2
	80	57.2	—	—	22200	23150	124	1

(Continued)

TUBULAR CHORD JIB RATINGS

NO. 7HL JIB RATING

Jib Offset	Jib Length		
	30'	40'	50'
0 to 6'	16,000*	14,000*	11,000
9'	16,000*	12,000	9,300
12'	14,000*	10,800	8,000
15'	—	9,500	7,000
18'	—	—	6,000
Effective Jib Weight at Boom Point	1,400	1,950	2,630

*Ratings require 7/8" rope. With 3/4" IPS rope max. capacity is 14,630 pounds. With 3/4" non-spin rope max. capacity is 12,450.

MAX. NO. 7HL JIB LENGTH PER BOOM

47S & 47H Booms – Max. 50' Jib
37H, 46S & 46H Booms – Max. 40' Jib

APPLICATION

400 Series – All Models
500 Series – All Models except 575C, 595C & 597C with 30H Boom
700 Series – All Models with 46S & 46H Booms

NO. 9HL JIB RATING

Jib Offset	Jib Length				
	40'	50'	60'	70'	80'
0 to 8'	19,000	17,000	14,500	12,500	10,500
12'	16,600	14,800	12,600	11,300	9,600
16'	14,400	12,800	11,600	10,100	8,600
20'	12,000	11,000	10,300	9,000	8,000
24'	—	—	9,000	8,000	7,000
28'	—	—	8,000	7,000	6,200
32'	—	—	—	—	5,400
Effective Jib Weight at Boom Point	1,850	2,350	2,750	3,700	4,300

MAX. NO. 9HL JIB LENGTH PER BOOM

77S & 92H Booms – Max. 80' Jib
59H Boom – Max. 60' Jib at all offsets, 70' & 80' Jibs at 0-8' offsets only
59S Boom – Max. 60' Jib
58H Boom – Max. 50' Jib
46H Boom – Max. 40' Jib at all offsets, 50' & 60' Jibs at 0-8' offsets only

APPLICATION

700 Series – Models 7250, 7260, 7460 & 7530
900 Series – All Models