

HITACHI SUMITOMO

# SCX400T

---

HYDRAULIC TELESCOPIC BOOM CRAWLER CRANE

---

## Specifications

*EN Rating*

# Specifications

HITACHI SUMITOMO

**SCX400T**

## Superstructure

### UPPER REVOLVING FRAME:

All-welded, precision machined, robust construction. Provided with machined surface for mounting load hoist and slewing unit assemblies, and mounting itself on turntable bearing. For structural integrate alignment of a 4-section telescopic boom and boom hoist cylinder, boom and cylinder foot pin holes are precisely machine bored too.

### TURNTABLE BEARING WITH INTERNAL SLEWING GEAR:

Single shear ball type; inner race of turntable bearing with integral, internal slewing (ring) gear bolted to lower frame, and outer race of turntable bearing bolted to upper revolving frame.

### CONTROL SYSTEM:

System contains two sets each of quadruplicate and single tandem valves which direct oil to various machine function and are actuated by control levers via remote controlled hydraulic servo for all motions. Working speeds can be precisely controlled by pilot-operated two universal joystick and three floor control levers including two as standard for travel and one as optional for aux. crane hoist drum controls. System takes an unique hydraulic circuit to maximize drum horsepower, and reduce horsepower loss with eliminating the possibility of engine stall.

### HYDRAULIC SYSTEM:

System provided with two variable displacement axial piston pumps each of 29.4MPa<math>300\text{kg/cm}^2</math>/216Lpm capacity, and one fixed displacement axial piston pump of 27.4MPa<math>280\text{kg/cm}^2</math>/135Lpm capacity for both independent and combined operations of all functions, and one fixed displacement gear pump of 4.9MPa<math>50\text{kg/cm}^2</math>/32.4Lpm capacity for system valve and cylinder controls.

**Main/opt. aux. crane hoist motors** — Variable displacement axial piston motor with counterbalance valve.

**Slewing motor** — Fixed displacement axial piston motor with spring-applied/power hydraulically released multiple wet-disc type brake for parking.

**Travel motors** — Shoe-in design; fixed displacement axial piston motor with brake valve and spring-applied/power hydraulically released multiple wet-disc type automatic brake.

**Pressure settings** — Rated and over-load relief pressure in each hydraulic circuit is set as under:

- Rated pressure settings:
  - Main crane hoist.....29.4Mpa
  - Boom telescoping.....20.7Mpa
  - Boom elevation.....23.1Mpa
  - Travel.....24.0Mpa
  - Slewing.....23.0Mpa
  - Pilot.....4.9Mpa
- Over-load relief pressure settings:
  - Main crane hoist.....31.4Mpa
  - Boom telescoping.....29.0Mpa
  - Boom elevation.....27.6Mpa
  - Travel.....24.0Mpa

**Oil cooler** — Aluminum-make; available for not only a good rustproof but also high cooling efficiency.

**Hydraulic oil reservoir** — 450 liters capacity.

**Kind of hyd. oil** — Standardized with ISO VG46 having viscosity ranging from 41.4 thru 50.6mm<sup>2</sup>/sec at 40°C.

**Line filters** — A 12 microns high-filtration full-flow filter element is incorporated in return line, and pilot filters and suction filters are designed for a good hydraulic oil filtration.

## LOAD HOIST ASSEMBLY:

Main crane hoist drum driven by hydraulic motor of bi-directional, variable displacement axial piston motor through a 2-stage planetary reduction gear unit powering the rope drum in either direction for hoisting and lowering load. Reduction gear unit installed within drum inside to realize a wider drum width. And, Power load lowering is only available as no clutch design is applied.

**Brakes** — Spring applied, power hydraulically released multiple wet-disc type automatic brake; provided within hyd. motor.

**Drum** — One piece, parallel grooved lagging with locking ratchet wheel cast integral; driven by a planetary reduction gear unit that involute-splines to drum shaft. Available to wind up approx. 25m long cable of 18mm dia. at drum 1st layer.

**Drum locks** — Electrically operated pawl.

**Aux. crane hoist drum** — Optional extra; available in the same design as that of standardized main crane hoist drum.

## SLEWING:

Driven by a bi-directional, axial piston hydraulic motor through 2-stage planetary reduction gear unit powering slewing pinion. Slewing pinion meshes with internal teeth of slewing (ring) gear of turntable bearing inner race.

**Brakes** — Spring-applied, power hydraulically released multiple wet-disc type; provided within hydraulic motor.

**Lock** — Mechanically operated drop pin.

**Speed** — 3.7min<sup>-1</sup> <3.7rpm>.

## OPERATOR'S CAB:

A 940mm wide, acoustically treated, full-vision, cushion rubber mounted, well-ventilated, full compartment, roomy operator's cab with a large front window with safety glass; provided with an arrangement of control station with two universal joystick, two travel and one optional aux. crane hoist drum control levers, sunvisor, sunshade, rear-view mirrors, an intermittent type window shield wipers with washer on both front and roof windows, sliding windows on left-hand side cab, and roll-down window on cab sliding door.

**Instrument panel** — Contains engine monitoring lamps, English WYLIE brand Load Moment Indicator, gauges & meter, warning lamps and other necessary controllers and switches.

**Operator's seat** — Full adjustable reclining seat with head rest and both R/H and L/H side arm rests.

**Anemometer** — Optional extra;

**Air-conditioner** — Provided as std.; built-in type full air-conditioning.

**Electric cab fan** — Optional extra; wind-direction adjustable type.

**Engine foot throttle** — Available in two(2) throttles of right-and-left-hand foot pedal and hand throttle.

**Operator's cab side step** — Available for access ease to operator's cab.

**AM/FM radio** — Provided as std. with clock.

**Fire extinguisher** — Optional extra; powder type.

## MACHINERY CAB:

Equipped with hinged doors on both sides for machinery access and inspection; affixed with tape-type non-skid material on the roof.

## COUNTERWEIGHTS:

Weighs 11.5ton with a 4-removable block consisting of "A" (4,900kg), "B" (2,800kg), "C" (2,800kg) and "D" (1,000kg).

## ELECTRICAL SYSTEM:

24-volt negative ground system; provided with two maintenance free batteries of 12V×150AH.

## LIGHTING SYSTEM:

Includes following lights.

- Two 70 W working lights;
- One 10 W interior cab light.

## REAR VIEW MIRRORS:

Two; provided on front-left and -right corners of superstructure.

## MICROPHONE & LOUD-SPEAKER:

Optional extra; this is for operator's convenience for loud speaking.

## POWER UNIT:

Make & Model	Isuzu 4HK1X
Type	Water-cooled, 4-cycle, direct injection, turbo-charged, diesel, intercooler
No. of Cylinders	Four(4)
Bore & Stroke	115 mm × 125 mm
Displacement	5,193 cc
Rated Output	147 kW/2,100 min <sup>-1</sup> 200 ps/2,100 rpm
Maximum Torque	688 N·m/1,500 min <sup>-1</sup> 70 kgf-m/1,500 rpm
Fuel Tank	300 liters

Note: 1. The engine meets Stage/Tier 3 of current smoke emission regulations in Europe, America and Japan.

2. An 147kW engine horsepower shown above is defined under a current international engine horsepower indication formula which includes necessary horsepower for engine alternator drive but excludes engine fan drive.

---

# Undercarriage

---

## LOWER FRAME:

All-welded, precision machined, box type construction; provided with four axle tips, and a clearance adjusting mechanism for better fitting between axles and crawler side frames. Provided a machined surface for mounting turntable bearing.

## CRAWLER SIDE FRAMES:

All-welded, box type construction, precision machined; each slide-assembled along lower frame axle tip boxes, and held in place by plate links with pins.

**Retract unit** — Available to power hydraulically extend/retract the crawler side frames. Controlled from operator's cab.

## DRIVE SPROCKETS:

Cast steel, heat treated; one per side frame. Track drive sprocket assembly bolt-coupled to 2-stage planetary reduction gear unit outer case as an integral part of shoe-in type traction motor. Sealed between parts of rotation and non-rotation of the motor with floating seal.

## IDLER WHEELS:

Cast steel, heat treated; one per side frame. Mounted on two bronze bushings with floating seals for lifetime lubrication.

## TRACK ROLLERS:

Ten per side frame; each heat-treated cast steel with double flange design. All mounted on two bronze bushings with floating seals for lifetime lubrication.

## CARRIER ROLLERS:

Two per side frame; each heat-treated cast steel with double flange design. All mounted on two bronze bushings with floating seals for lifetime lubrication.

## TRACKS:

Tractor type; provided with induction-hardened, alloy, triple grouser shoes, and heat-treated track link pins with dirt seals; 56 pcs. per side frame.

**Shoe width** — 810mm wide.

**Track adjustment** — Hydraulic track adjustment with shock-absorbing recoil spring is provided on each track.

## TRAVEL AND STEERING:

A bi-directional, shoe-in type axial piston hydraulic motor bolt-couples with drive sprocket thru 2-stage planetary reduction gear unit outer case at each crawler side frame end for travel and steer. Straight-line travel (forward or reverse), pivot or differential turns, and counter-rotation for spin turns are available.

**Brake** — Spring-applied, power hydraulically released multiple wet-disc type automatic brake; located within hydraulic motor. Brakes automatically set when travel levers are in neutral or when engine is shut down.

**Travel speed** — 1.9km/hr. (based on flat, level and firm supporting surface, and under the conditions that no load must be applied and front-end att. must be the standardized 4-section telescopic boom only).

**Gradeability** — 40% (22°) permissible based on basic machine without front-end attachment.

---

# Safety Devices

---

## LOAD MOMENT INDICATOR:

English WYLIE brand; this is a full computerized automatic over-load prevention system which meets EN Standards; Included in the design is (1) no zero-point adjustment, (2) operator selected crane configuration on graphic display panel (3) optional range and slew angle limit settings.

**Construction (standard version)** — Comprises (1) pressure transducers (2) boom angle sensor/length sensor (3) computerized Micro Processing Unit (M.P.U.) and (4) graphic display panel.

**Functions** — This system functions by informing the crane Operator with the activation of a yellow LED and internal buzzer when the load lifted reaches 95% of the cranes capacity and by a red LED and external audible alarm when the lifted load exceeds 102.5% of the cranes capacity. At this point the unsafe motions of the crane are automatically stopped. The safe motions are allowed except for the boom up operation that is only allowed by the operation of a spring return switch in the operators cabin.

**Display panel design** — A graphic display panel in clear view to the operator allows the inputting of the cranes configuration. It displays all relevant information including "Allowable rated load", "Actual lifted load" and the cranes current status "Utilisation bargraph", "Radius", "Boom length", "Boom angle", "Parts of hoist", "Winch selected" etc. If option is installed the operator can also select a working range and the crane will be automatically restricted to work only in the pre-defined area.

## DRUM ROPE OVER-PAYOUT LIMITER:

Optional extra; Available on both main and opt. aux. crane hoist drums, and functions to automatically stop drum rotation when no. of rope winding at 1st layer becomes three(3).

**HOOK OVER-HOISTING LIMITER:**

Limit switch type. Available to prevent hook over-hoisting with functions of automatic drum braking with hydraulic lock, and warning by buzzer.

**SLEW LOCK:**

Mechanically operated drop pin; available to firmly lock superstructure in two positions of facing front and rear to undercarriage.

**DRUM LOCK:**

Electrically operated pawl locks is available on main crane hoist drum.

**SLEWING BRAKE SAFETY CIRCUIT:**

Available not to start engine whenever slewing brake is off.

**HOOK LATCH:**

Provided on every kinds of hook to prevent out of place of cable from hook.

**SLEWING ALARM:**

This is by buzzer, and flasher lamps located on both sides of machinery cab.

**SIGNAL HORN:**

Available as warning just before every kinds of motions are initiated.

**LOCK LEVER (FOOL PROOF SHUT-OFF LEVER):**

Located in the cab exit; this is available to automatically deactivate and lock hydraulic system.

**LMI SAFETY CIRCUIT-OFF SWITCH:**

Available in key type for a good crane safety operation management without fail.

**GAUGES & METER:**

Engine water temperature gauge, fuel gauge and hour-meter are provided on instrument panel.

**ENGINE MONITORING LAMPS:**

Available to let operator warn engine abnormal conditions as to battery charge, lubrication oil pressure, radiator coolant level, oil filter clogging, air filter clogging, water temp., and glow plug; provided on instrument panel.

**THREE COLOR PERCENTAGE INDICATOR:**

Optional extra; This is with three colors of Green, Yellow and Red. Each color indicates the load percentage to rated capacity; Green shows less than 95% as safety, Yellow shows 95 to 102.5% as marginal, and Red shows over 102.5% as over-loading. As further function, Red lamp comes on automatically when operator cuts off safety circuit of the LMI absentmindedly.

**LEVEL GAUGE:**

Optional extra; bubble type. Located on operator's cab floor of superstructure.

**AUX. HOOK OVER-HOISTING LIMITER:**

Optional extra; this is available for auxiliary crane hoist with optional aux. auxiliary lifting sheave, Performs the same function as that of "Hook over-hoisting limiter" mentioned before.

---

## Front-end Attachment

---

**BOOM:**

A 4-section full power, box construction, telescopic boom under American Link-Belt's patented design; boom side plates is designed with diamond shaped impressions for superior strength to weight ratio and 689.5MPa angle chords for lateral stiffness. In addition, boom telescope sections are supported by adjustable side wear shoes both vertically and horizontally to prevent metal-to-metal contact.

Length.....10.06m to 32.00m with a 4-section.

Boom telescoping.....Available in two modes of "B" and "A" as under:

Mode "B" — This is basic mode, and is the full power, synchronized mode of telescoping all sections proportionally.

Mode "A" — This is an exclusive mode to extend only 2nd section to 17.37m offering increased capacities for in-close, maximum capacity picks.

Boom telescoping speed — Approx. 70 sec. (from 10.06m to 32.00m).

Boom head.....Four(4) head and two(2) guide of 0.42m root diameter nylon sheave mounted on anti-friction bearing; provided with quick cable reeve design, and easily removable cable guards.

Boom elevation.....Available from -3°to78°; provided with one Link-Belt designed hydraulic cylinder with holding valve and bushing in each end.

Boom elevating speed — Approx. 40sec. (from zero to 78 degrees).

**AUXILIARY LIFTING SHEAVE:**

Optional extra; all-welded construction having head machinery with 0.42m root diameter nylon sheave mounted on anti-friction bearing with removable wire rope guard. Pinned to top of tip section. Available to lift light load of 5ton or less under one part-line off the optional aux. crane hoist drum.

**FLY-JIB LIFTING SHEAVE:**

Optional extra; all-welded construction having head machinery with 0.42m root diameter nylon sheave mounted on anti-friction bearing with removable wire rope guard. Pinned to top of tip section. Available to lift light load of 5ton or less under one part-line off the optional aux. crane hoist drum. Fly jib length is 6.1m.

**HOOK BLOCKS:**

Sheaves all mounded on anti-friction bearings. Available in 4 kinds of capacities as under:  
 40t, four sheaves.....Optional extra.  
 30t, three sheaves.....Optional extra.  
 15t, one sheave.....Optional extra.  
 5t, ball hook.....Optional extra.

**DRUM DATA:**

Drum	Root dia.	Type	Line speed (Hoisting, Lowering)	Cable	Max. line pull
Main	402mm	Parallel grooved (Lebus type)	100/ 65mpm	18mm	85kN 8.7t
Optional Auxiliary	402mm	Parallel grooved (Lebus type)	100/ 65mpm	18mm	85kN 8.7t

**Notes:**

1. Line speed is based on drum first layer and rated engine rpm under no load condition.
2. Hoisting line speed varies under load and operating conditions.

**HOIST REEVING:**

(t)

Kind of hook block \ No. of partline	8	7	6	5	4	3	2	1
40t	40.0	35.0	30.0	25.0	20.0	15.0	10.0	5.0
30t	—	—	30.0	25.0	20.0	15.0	10.0	5.0
15t	—	—	—	—	—	15.0	10.0	5.0
5t	—	—	—	—	—	—	—	5.0

**CABLES:**

Main drum .....IWRC 6×WS (31), 18mm dia./170m long, breaking load 238kN 24.3t .  
 Opt. auxiliary drum.....Optional extra; IWRC 6×WS (31), 18mm dia./80m long (with aux jib) / 100m long (with fly jib) breaking load 238kN 24.3t .

## LIFTCRANE CAPACITIES (1) - Boom telescoping mode "B"

Boom length (m) Working radius (m)	10.06	12.19	15.24	18.29	21.34	24.38	27.43	30.48	32.00
2.5	40.00								
3.0	35.00	15.80	15.80	15.80					
4.0	28.40	15.80	15.80	15.80	15.80/4.6				
5.0	22.50	15.80	15.80	15.80	15.80				
6.0	16.90	15.80	15.80	15.80	15.80	13.80/6.1	12.20/6.1		
7.0	13.30	13.40	13.50	13.60	13.70	12.40	11.20	9.40/7.6	7.90/7.6
8.0	11.70/7.6	11.00	11.10	11.20	11.20	11.00	10.10	9.10	7.90
9.0		9.20	9.30	9.40	9.40	9.50	9.10	8.40	7.90
10.0			7.90	8.00	8.10	8.10	8.10	7.70	7.30
11.0			6.90	6.90	7.00	7.00	7.10	7.10	6.70
12.0			6.00	6.10	6.10	6.20	6.20	6.20	6.20
13.0			5.80/12.2	5.30	5.40	5.40	5.50	5.50	5.50
14.0				4.70	4.80	4.80	4.90	4.90	4.90
15.0				4.20	4.30	4.30	4.30	4.40	4.40
16.0				4.10/15.2	3.80	3.90	3.90	3.90	3.90
17.0					3.50	3.50	3.50	3.50	3.50
18.0					3.10	3.10	3.20	3.20	3.20
19.0						2.80	2.90	2.90	2.90
20.0						2.60	2.60	2.60	2.60
21.0						2.30	2.40	2.40	2.40
22.0							2.20	2.20	2.20
23.0							1.90	1.90	2.00
24.0							1.70	1.70	1.70
25.0								1.60	1.60
26.0								1.40	1.40
27.0								1.20	1.20

## LIFTCRANE CAPACITIES (2) - Boom telescoping mode "A"

Boom length (m) Working radius (m)	10.06	12.19	15.24	17.37
2.5	40.00			
3.0	35.00	32.50	31.50	19.50
4.0	28.40	27.00	26.00	19.00
5.0	22.50	21.70	21.00	16.80
6.0	16.90	16.60	16.30	14.50
7.0	13.30	13.00	12.80	12.50
8.0	11.70/7.6	10.60	10.40	10.30
9.0		8.80	8.70	8.60
10.0			7.30	7.20
11.0			6.30	6.20
12.0			5.40	5.30
13.0			5.30/12.2	4.60
14.0				4.10
15.0				3.50
16.0				3.40/15.2

### WORKING MASS & GROUND CONTACT PRESSURE:

Shoe width	Mass	Pressure
810mm	45.2t	55.8kPa <0.57kg/cm²>

Note: Working mass shown above is with a 4-section telescopic boom, 11.5ton counterweight, and 40t hook block.

**Notes — Liftcrane capacities**

**1. GENERAL:**

- (1) WARNING !! IT IS A MUST TO READ AND UNDERSTAND THE OPERATOR'S MANUALS AND THE FOLLOWING INSTRUCTIONS AND RATED LIFTING CAPACITIES BEFORE OPERATING CRANE. OPERATION WHICH DOES NOT FOLLOW THESE INSTRUCTIONS MAY RESULT IN AN ACCIDENT.
- (2) Capacities are in metric tons, and are rated in accordance with EN13000 Standard; the figures surrounded by bold lines are based on the factor of machine structural strength limitations according to EN13000 Standard or hydraulic limitations.
- (3) Rated lifting capacities as shown on these charts pertain to this crane as originally manufactured and normally equipped. Modifications to the crane or use of optional equipment other than that specified can result in a reduction of capacity.
- (4) Construction equipment can be dangerous if improperly operated or maintained. Operation and maintenance of this crane must be in compliance with the instruction/information in the Operator's and Parts Manuals supplied with this crane. If these manuals are missing, it is certain'y required to order us or nearest distributor the replacements.
- (5) The operator and other personnel associated with this crane shall read and fully understand the latest applicable European safety standards like EN414.
- (6) The rated lifting capacities are based on crane standing level on firm supporting surface.

**2. SET-UP:**

- (1) The crane shall be leveled on a firm supporting surface. Depending on the nature of the supporting surface, it may be necessary to have structural supports under the crawler shoes for its level.
- (2) When making lifts, crawler side frames must be fully extended.
- (3) An 11.5ton counterweight is required for all capacities on these charts.
- (4) When operating, maximum boom angle shall not exceed 78 degrees.
- (5) As to required number of part line, see "HOIST REEVING" described in page 6 here.

**3. OPERATION:**

- (1) Rated lifting capacities at rated radii shall not be exceeded. Do not tip the crane to determine allowable loads.
- (2) Rated lifting capacities include the weight of hook block, weighted ball, slings, spreader bar or other suspended gear. These weights must be subtracted from the listed rated capacity to obtain the net load that can be lifted. Weights of hook blocks available from manufacturer are as under:  
40t.....0.42ton    30t .....0.35ton    15t.....0.25ton  
5t.....0.13ton
- (3) All capacities are rated for 360° slewing.
- (4) Least stable rated condition is over the side.
- (5) Rated lifting capacities are based on freely suspended loads. No attempt shall be made to move the lifting load from the ground in any direction.
- (6) Rated lifting capacities are for lift crane service only.
- (7) It is certainly required to operate within maximum radii of each boom length where capacities are listed; if operated at any radii out of ranges listed, the crane will tip or cause boom failure.
- (8) The maximum loads that can be telescoped are not definable because of variation in loadings and crane maintenance, but it is permissible to attempt retraction and extension within the limits of the applicable load rating chart.
- (9) The machine can be steplessly operated in the range of not only working radius between 2.5m and 27.0m, but also boom length from 10.06m thru 32.00m safely; capacities which are available but are not described in these charts are automatically set up by a computerized automatic over-load preventing system, English WYLIE brand Load Moment Indicator.

- (10) The user shall operate at reduced ratings to allow for adverse job conditions, such as: soft or uneven ground, out of level conditions, wind, side loads, pendulum action, jerking or sudden stopping of loads, hazardous conditions, experience of personnel, traveling with loads, and so on. Side load on boom is dangerous and shall be avoided.
- (11) Rated lifting capacities do not account for wind on suspended load or boom.
- (12) Aux. lifting sheave capacities are almost equal to the figures made by the deduction of a 250kg from the liftcrane capacities unless restricted by its maximum capacity of 5ton. As to the details, please consult us or nearest distributor.
- (13) Power sections of boom must be extended in accordance with boom mode "A" or "B" (see page 10, Boom Telescoping Mode).
- (14) Capacities when handling load off main boom head sheaves in case of mounting lattice fly or auxiliary lifting sheave on top of boom are detailed; if required, please consult us or nearest distributor.
- (15) Rated lifting capacities are based on correct no. of part-line. Deduction must be made for excessive no. of part-line. Any hoist cable reeving over the figure as required as minimum is considered excessive and must be accounted when making lifts. It is suggested Working Range Diagram is used to estimate the extra meter of rope then deduct 1.5kg for each extra meter of wire rope before lifting the load.
- (16) In capacity charts, the working radius from center of rotation of the machine to center of vertical hoist line are under loaded conditions.



# Fly Jib Capacitie - EN Rating

## Boom telescoping mode "A" "B"

Unit : t

Boom length (m)	10.06 - 24.38			27.43 - 32.0		
	Jib offset angle (°)			Jib offset angle (°)		
Working radius (m)	2	20	40	2	20	40
7.8	5.00					
8	5.00					
9	5.00	9.5mx4.50 t				
10	5.00	4.50	3.70	10.1mx4.50 t		
12	5.00	4.50	3.70	4.50	11.7mx3.80 t	
14	5.00	4.40	3.60	4.10	3.80	13.1mx3.50 t
16	4.50	4.20	3.60	3.70	3.50	3.30
18	3.50	3.75	3.50	3.50	3.20	3.00
20	2.95	3.00	3.10	2.85	2.95	2.90
22	2.45	2.50	2.60	2.35	2.40	2.55
24	2.05	2.10	22.2mx2.55 t	1.90	2.00	2.10
26	1.65	1.70		1.60	1.70	1.75
28	27.3mx1.50 t	26.9mx1.55 t		1.30	1.35	27.7mx1.45 t
30				26.9mx1.10 t	26.9mx1.15 t	

1. All sections telescope simultaneously.
2. The rated loads are determined according to EN13000 rating on the condition that the machine is stationed on firm, level ground.
3. To calculate the maximum load that can actually be lifted, deduct weight of all lifting accessories, such as main hook, from figures shown above.
4. Working radius is the horizontal distance from the slewing center to the center of gravity of a lifted load.
5. The counterweight is 11.5 t.
6. Be sure to fully extend the side frames before operating the machine.
7. For boom lengths not listed, use rating for next longer boom length or next shorter boom length, whichever is smaller.
8. Fly-jib length is 6.1m.

## Mode "A"

Only 2nd section telescopes.

## Boom Length (m)

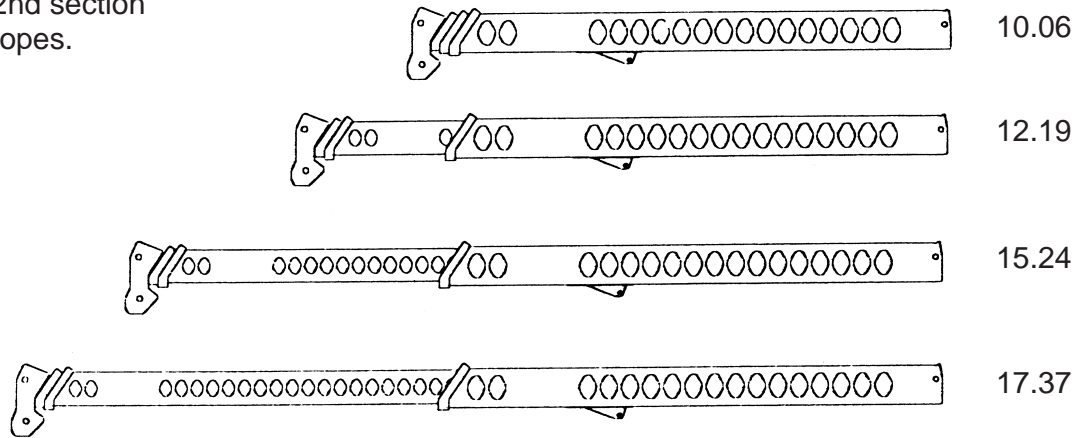

2nd section  
7.315m Stroke

Base section

## Mode "B"

2nd, 3rd and tip section telescopes simultaneously.

## Boom Length (m)

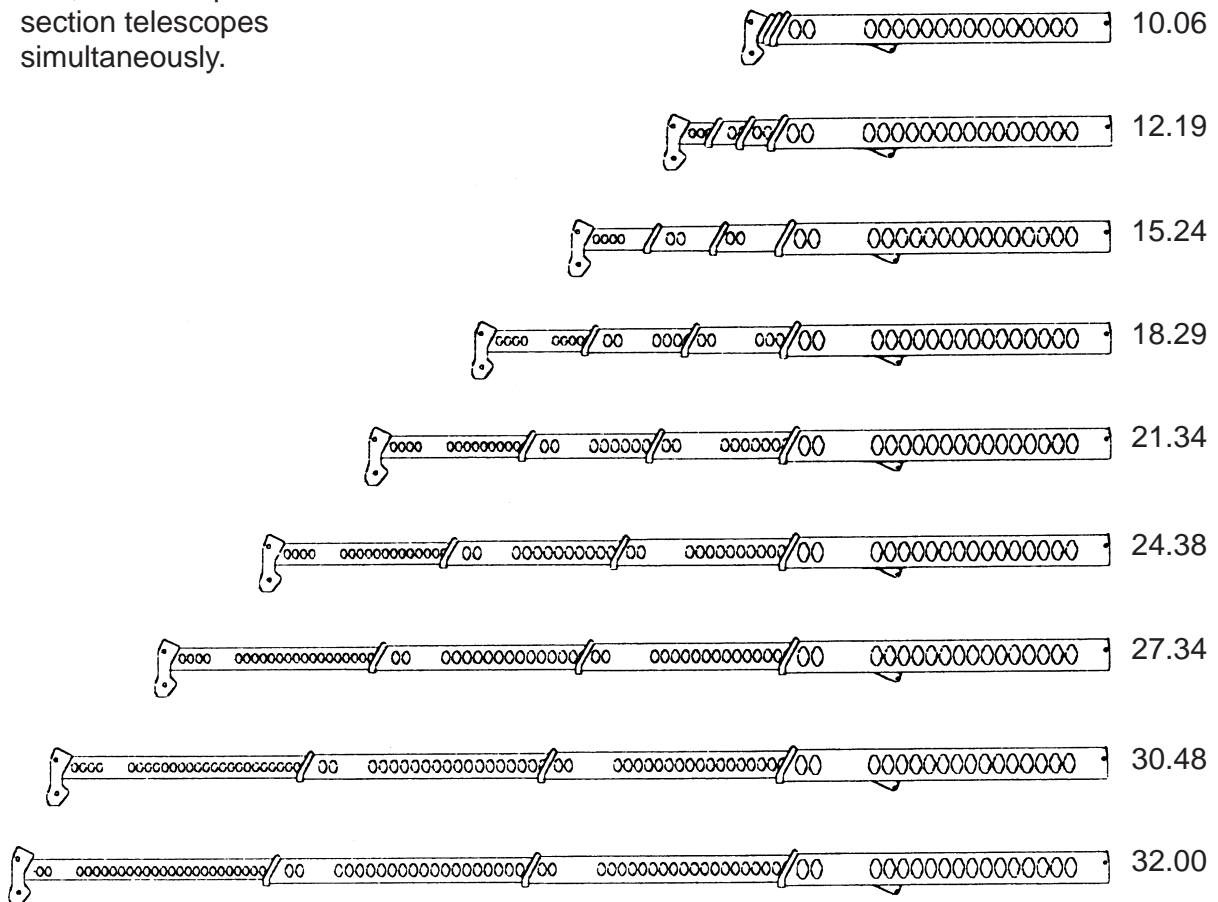

Tip section  
7.315m Stroke

3rd section  
7.315m Stroke

2nd section  
7.315m Stroke

Base section

# Lift Crane Working Ranges

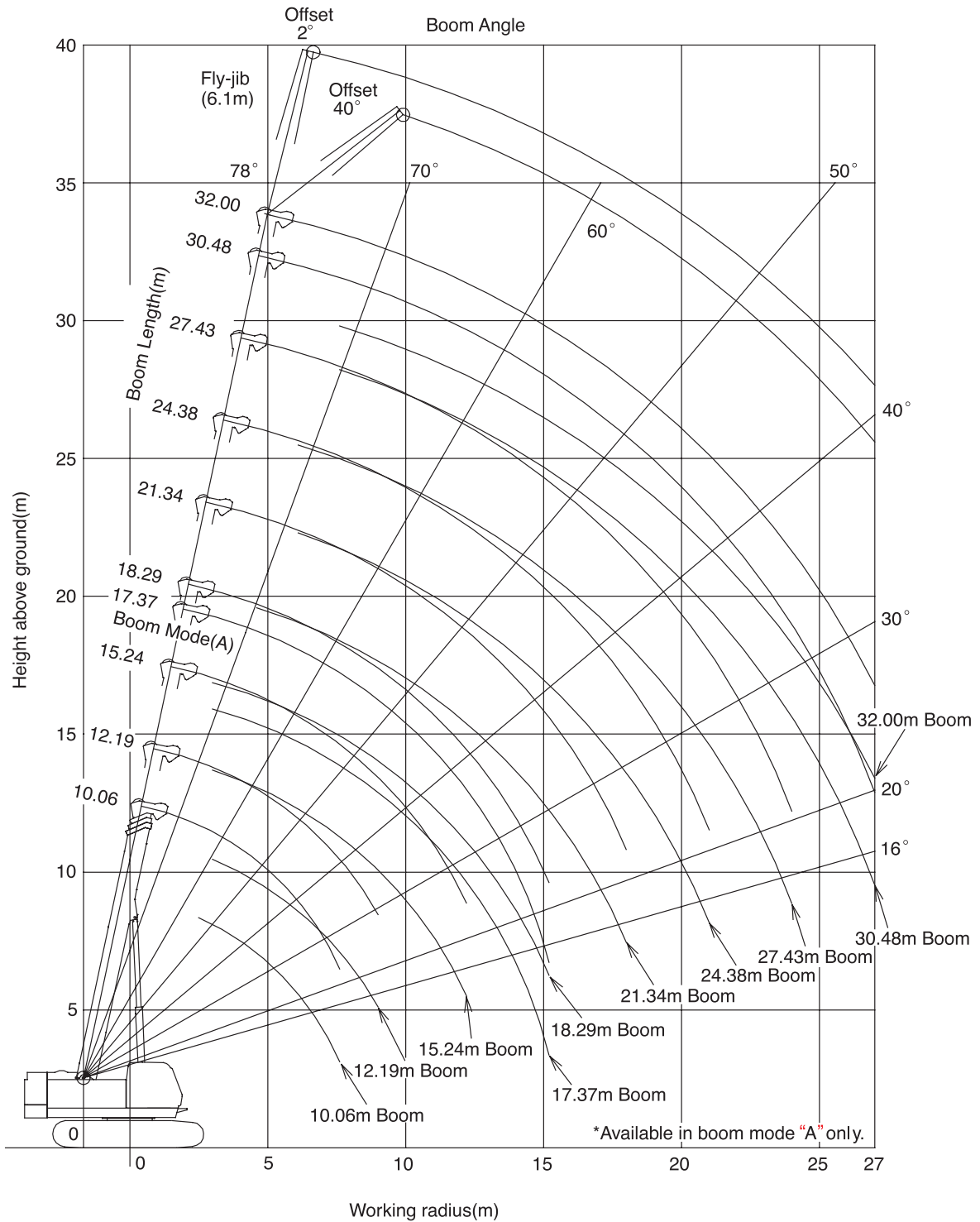

**Notes :**

1. The above diagram shows two kinds of locuses of boom peak sheave and hook points; the lower lines each indicate the locus of hook point, and upper lines each show the locus of boom peak sheave point.
2. A 4-boom length of 10.06/12.19/15.24/17.34m is available in boom telescoping mode "A" while a 9-boom length of 10.06/12.19/15.24/18.29/21.34/24.38/27.43/30.48/32.00m is available in mode "B".

# General Dimensions (w/Service refill capacities data)

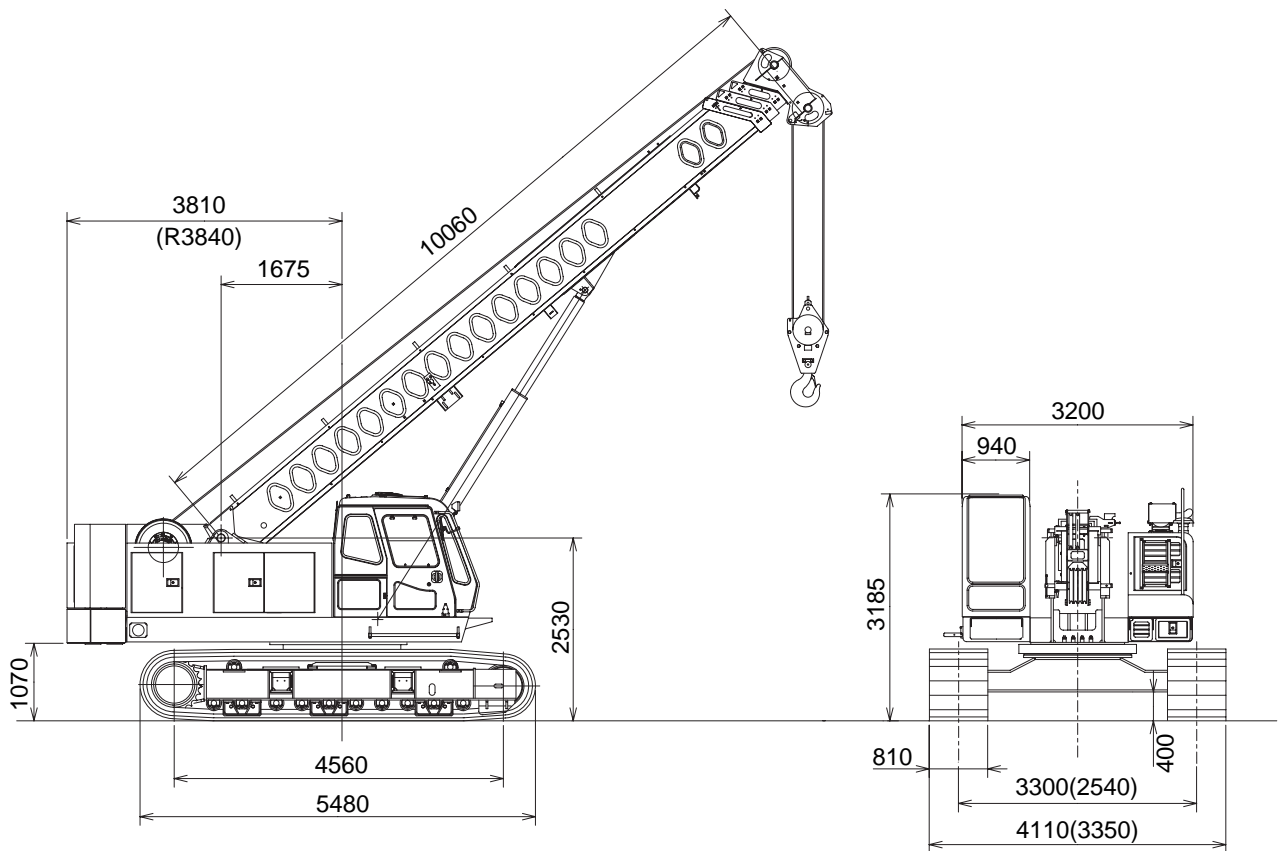

(mm)

Note: The figures in parenthesis are in the case that crawler side frames are fully retracted.

## Service Refill Capacities (in liters):

Full tank .....	300
Engine coolant .....	27
Engine oil .....	23
Main crane hoist drum reduction gear unit .....	11.5
Slewing reduction gear unit .....	8
Travel reduction gear unit .....	11.5x2
Hydraulic system, including reservoir tank capacity .....	650
Hydraulic oil reservoir .....	450

# Standard and Optional Equipment

	Standard equipment	Optional equipment
<b>Superstructure</b>	<ul style="list-style-type: none"> <li>● Isuzu 4HK1X diesel engine with an 148kW &lt;200ps&gt; rated output;</li> <li>● Hydraulic system with two variable/one fixed displacement axial piston pumps and one fixed displacement gear pump; provided with aluminum-make oil cooler;</li> <li>● Control system with two sets each of quadruplicate and single tandem valves and pilot-operated universal joystick and floor control levers; provided with an unique hydraulic circuit to always maximize engine output under any load condition;</li> <li>● Main crane hoist drum winch of 85kN 8.7t line pull with 402mm dia. drum lagging driven by variable displacement axial piston type hyd. motor; provided with a multiple wet-disc type automatic brake;</li> <li>● Slewing mechanism with turntable bearing; driven by one hyd. motor w/spring-applied, power hydraulically released multiple wet-disc brake; provided with slew lock device;</li> <li>● 940mm wide, full-vision operator's cab with a large front window; provided with an arrangement of operator control station with two universal joystick, two travel control and one optional aux. crane hoist drum control levers, air-conditioner and instrument panel;</li> <li>● 11.5ton counterweight;</li> <li>● Machinery cab with hinged doors;</li> <li>● 24-volt electrical system with two 12-volt batteries;</li> <li>● Lighting system; <ul style="list-style-type: none"> <li>• Two 70W working lights;</li> <li>• One 10W interior cab light;</li> </ul> </li> <li>● Rear view mirrors;</li> <li>● Accessories; <ul style="list-style-type: none"> <li>• AM/FM radio w/clock;</li> <li>• Engine hourmeter;</li> <li>• Fuel gauge;</li> <li>• Eng. water temp. gauge;</li> <li>• Engine over-heat indicator;</li> </ul> </li> <li>● Dual intermittent window shield wipers with washers; available on both front and roof windows;</li> <li>● Cigar lighter;</li> <li>● Ashtray;</li> <li>● Sunvisor;</li> <li>● Sunshade;</li> <li>● Non-skid surfaces;</li> <li>● Cab floor mat;</li> <li>● Engine foot throttle;</li> <li>● Built-in type full air conditioner;</li> <li>● Cab front step;</li> <li>● Cab side step;</li> <li>● Superstructure under-cover.</li> </ul>	<ul style="list-style-type: none"> <li>● Aux. crane hoist drum winch;</li> <li>● Microphone &amp; loud-speaker;</li> <li>● Drum light;</li> <li>● Fire extinguisher;</li> <li>● Electric cab fan;</li> <li>● Level gauge.</li> </ul>

	Standard equipment	Optional equipment
<b>Undercarriage</b>	<ul style="list-style-type: none"> <li>● 3,350mm gauge by 5,480mm long crawler lower with power hydraulically retractable/extendible crawler side frames;</li> <li>● Crawler drive units with shoe-in type traction motor with wet-disc type automatic brakes;</li> <li>● Tractor type tracks with 810mm wide 3-bar grouser shoes;</li> <li>● Hydraulic track adjusting devices with recoil spring;</li> <li>● Lifetime lubricated track components;</li> </ul>	
<b>Liftcrane Att.</b>	<ul style="list-style-type: none"> <li>● A 4-section, full power, box construction, telescopic boom extending from 10.06m to 32.00m with American Link-Belt's patented design;</li> <li>● Four nylon boom head sheaves w/two nylon guide sheaves with quick cable reeve design;</li> <li>● A Link-Belt designed power hydraulic boom hoist cylinder;</li> <li>● Main crane hoist cable; 18mm dia./170m long.</li> </ul>	<ul style="list-style-type: none"> <li>● Short jib;</li> <li>● Fly jib;</li> <li>● Aux. lifting sheave;</li> <li>● Aux. hoist cable;</li> <li>● Hook block (5ton, 15ton, 30ton, 40ton).</li> </ul>

	Standard equipment	Optional equipment
<b>Safety Devices</b>	<ul style="list-style-type: none"> <li>● English WYLIE brand Load Moment Indicator; this is a computerized automatic over-load preventing system; provided with a graphic display panel allowing the inputting of the cranes configuration, and a function indicating present lifting conditions like “actual lifted load”, “allowable rated load”, “boom length”, “working radius”, “boom angle”, and so on;</li> <li>● Lock lever (Fool proof shut-off lever);</li> <li>● Emergency engine stop switch;</li> <li>● LMI safety circuit-off switch;</li> <li>● Hook over-hoisting limiter;</li> <li>● Slewing alarm;</li> <li>● Slew lock;</li> <li>● Main crane hoist drum pawl lock;</li> <li>● Slewing brake safety circuit;</li> <li>● Signal horn;</li> <li>● Hook latch;</li> <li>● Engine monitoring lamps;</li> <li>● Drum mirror.</li> </ul>	<ul style="list-style-type: none"> <li>● Three color percentage indicator;</li> <li>● Anemometer;</li> <li>● Cabin roof window guard;</li> <li>● Travel alarm;</li> <li>● Aux. hook over-hoisting limiter;</li> <li>● Drum rope over-payout limiter;</li> <li>● Emergency escape hammer.</li> </ul>

SCX400T

## Hitachi Sumitomo Heavy Industries Construction Crane Co., Ltd.

9-3, Higashi Ueno 6-chome, Taito-ku, Tokyo 110-0015, Japan

Phone: 81-3-3845-1387 Facsimile: 81-3-3845-1394

<http://www.hsc-crane.com>

- We are constantly improving our products and therefore reserve the right to change designs and specifications without notice.
- Units in this specification are shown under International System of Units; the figures in parenthesis are under Gravitational System of Units as old one.

---

Address Inquires to: