

Model 8716 Crane

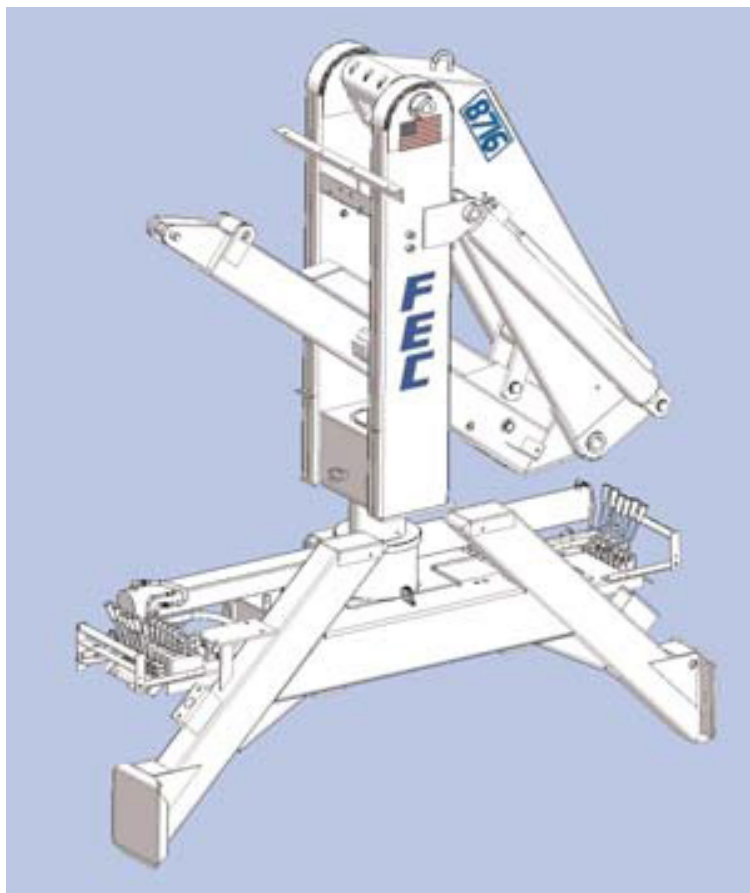

- Load holding valves on all lift cylinders.
- Rack and pinion rotation for superior power and durability.
- Center mounted with “A” frame outriggers.
- Overload by-pass system built into main control valve banks.
- Optional Radio remote control with manual lever back up.

96,000 ft. lbs. Rating

Crane Capacity Rating:	12,000 lbs.
Maximum Reach:	16'
Crane Weight:	3,800 lbs.
Chassis RBM Required:	1,240,000 in. lbs.