

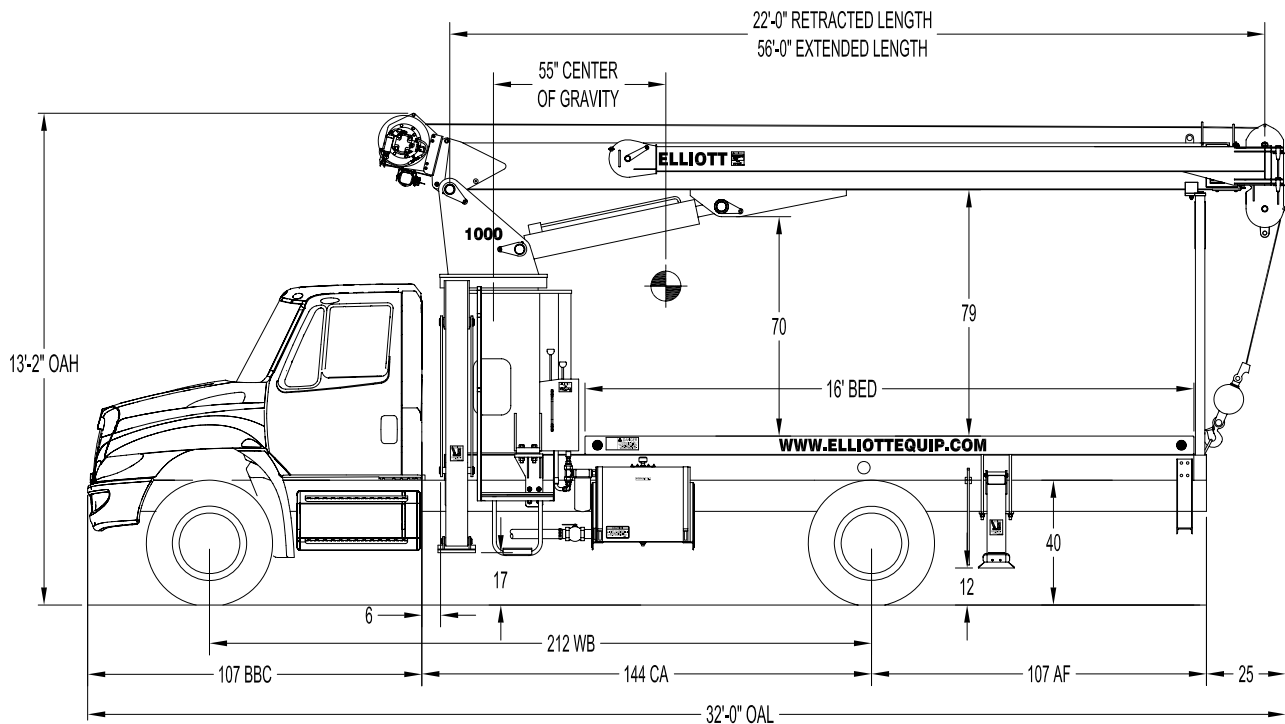

1056F SIDE VIEW DIAGRAM



- | | | | |
|---------------------------------|-------------------------------------|---------------------------------|-----------------------|
| • Maximum Vertical Reach | 96'/29.2 m | • Powered Boom Sections | 3 |
| • Working Area | 180 Degrees Standard (360 Optional) | • Overall Height | 13'2"/4 m |
| • Lifting Capacity | 20,000 lbs/9,072 kg | • Operator Controls | Dual Operator Standup |
| • Boom Length | 56'/17.1 m | • Outrigger Type Front | A-Frame |
| • Crane Weight (Dry) | 13,390 lbs/6,074 kg | • Outrigger Spread Front | 17'7"/5.3 m |
| • Jib Lengths | 18', 18'-30'/5.5 m, 5.5-9.1 m | • Outrigger Type Rear | A-Underslung |
| • Winch Bare Drum Pull | 12,800 lbs/5,806 kg | • Outrigger Spread Rear | 10'4"/3.1 m |

TECHNICAL SPECIFICATIONS

Crane Capacity: 20,000 lbs at five feet load radius.

Maximum Tip Height: 66' height (96' with optional 30' jib)

Control Console: Dual operator standup control stations equipped with four single axis control levers for the main crane controls. Operator station includes bubble level gauge, engine start/stop switch, signal horn button, variable speed foot throttle, lifting capacity chart, range diagram chart, boom angle indicator, system pressure gauge, 12V DC power source, and cup holder. Outrigger lever controls at control consoles.

Boom: Three-section fully proportional, high strength steel plated rectangular tube sections. A maximum boom tip height of 66' mounted on a truck. The boom nose contains one floating upper sheave and two lower sheaves. Assembly includes heavy-duty cylinder fittings, pivot pins, and replaceable wear pads.

Winch: Mounted at the base of the boom for a long fleet angle and flat level spooling of cable. Winch is driven by a planetary reducer and powered by a hydraulic motor. Burst-of-speed winch provides increased line speed. The winch brake is spring applied, pressure release design. Supplied with 275' of 9/16" wire rope with a single line pull of 9,600 pounds, and a downhaul ball with swivel hook for single part line.

Load Moment Indicator System:

System senses hoist cylinder pressures, boom length and boom angle with hydraulic function lockout. The display console is equipped with a bar graph showing crane utilization, boom angle or boom length, a mode select controls for main boom and jib operation, and an anti-two block with an audio/visual warning and shut-off functions to limit hook-boom point contact.

Outriggers: One set of "A" Frame main outriggers with 17'7" span, and

one set of underslung "A" auxiliary outriggers with a 10'4" span.

Frame: Full length, all welded rigid 4-plate design sub-frame. Sub-frame allows for bolt-on addition of 16' bed.

Turret: Reverse offset turret is one-piece weldment. Turret rotates on large diameter ball bearing.

Rotation: Hydraulic motor drives turret through double reduction planetary swing drive for 372-degree non-continuous rotation. The swing drive system has a spring applied, pressure release brake.

Lift: One double-acting long stroke cylinder provides smooth and stable boom elevation. Holding valve prevents boom from falling in event of hose failure.

Boom Extension: Incorporates a single-stage hydraulic extension cylinder, attached to the largest boom section, with a proportional cable extension system driving the outermost section.

Hoses: All high pressure hoses are wire braid reinforced with a minimum safety factor of 4 to 1.

Cylinders: All cylinders use microhoned cylinder tubing, chrome shafts, top grade packing and protective rod wipers. Cylinder-mounted holding valves provided on all load-holding cylinders.

Hydraulic System: Equipped with cable-shift PTO, three-section gear pump, SAE O-ring face seals on pressure lines, and a 10-micron return line filter. The control valve distributes all flow to hoist system, swing circuit, and other crane functions. System is open center type.

Oil Tank Capacity: 70 gallon mounted to truck frame on roadside.

Cab Equipment: PTO cable with indicator lights installed in truck cab. U/L approved 5:BC dry chemical fire extinguisher installed in truck cab.

Operators Manual & Video: Two CD copies and one hard copy of operation, maintenance, safety and parts manual provided with each unit. Operational and safety video provided at delivery.

Installation: Unit installed on chassis, painted, system and tank filled with oil, tested, inspected, and ready to operate.

Standard Paint: Paint turret and boom white, outriggers red, and bed and boxes black.

Bumper: Bureau of Motor Carrier Safety rear bumper.

Weight: Approximately 13,390 lbs. with 16' steel-floor bed less truck.

Truck Chassis Required: Approx. 144" C.A. RBM 1,100,000 in-lb. per rail, 13,000 lb. front axle and 33,000 lb. GVWR required. Trucks must have front frame extension, 12V electrical system with high capacity alternator, cab clearance stop/tail/backup lights, and I.D. lamps. Recommended GVWR is minimum for BOOMTRUCK with flatbed only. Contact factory when additional equipment is to be added.

Options:

18-30' Telescopic Material Handling Jib.

Radio Remote Controls.

Superlink Short Jack Outriggers.

Gravity Leveled Steel Basket.

Front Jack for 360 Degree Area of Operation.

Hydraulic Tool Circuits on Bed.

Much more...

Elliott Equipment Company reserves the right to change the specification of any unit at any time without prior notice. This brochure is only a statement of general specifications on the date of this publication. For more detailed info on specific Elliott trucks go to www.elliottequip.com

MAXIMUM LIFTING CAPABILITIES

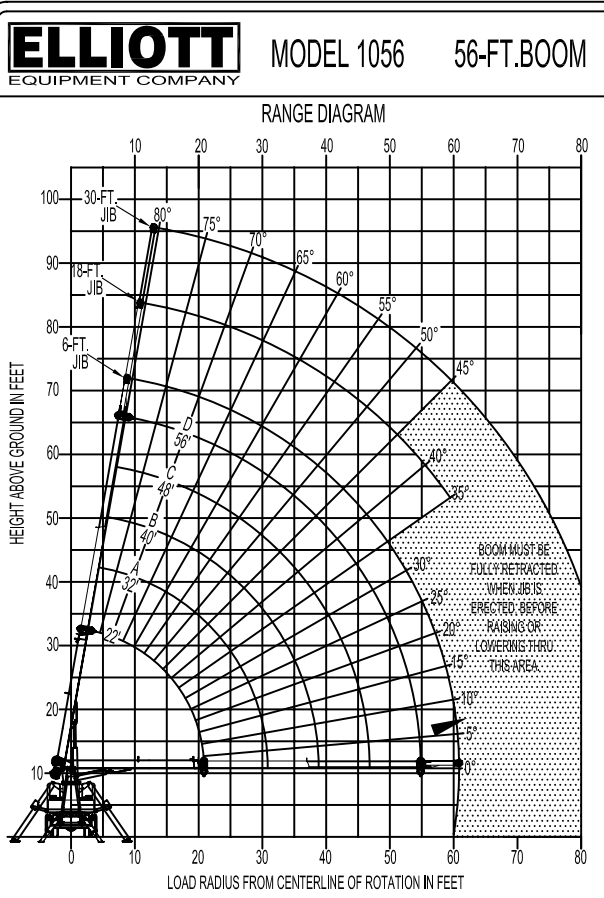

ALLOWABLE LINE PULL			NOTICE
1-PART LINE	2-PART LINE	3-PART LINE	
			<ul style="list-style-type: none"> - DO NOT DEADHEAD LINE BLOCK AGAINST BOOM TIP WHEN EXTENDING BOOM. - KEEP AT LEAST 5 WRAPS OF LOADLINE ON THE WINCH DRUM AT ALL TIMES. - USE ONLY 9/16" DIAMETER WIRE ROPE, AS SPECIFIED BELOW, WITH THE PROPER BREAKING STRENGTHS LISTED. - ANTI-TWO-BLOCK SYSTEM MUST BE IN GOOD OPERATING CONDITION BEFORE OPERATING CRANE. SEE OPERATION & SAFETY MANUAL. - MAXIMUM CAPACITY WITH "BURST OF SPEED" IS 500 LBS.
9600-LBS.	19200-LBS.	20000-LBS.	
9060-LBS.	18120-LBS.	20000-LBS.	<ul style="list-style-type: none"> 9/16" - 6 x 37 IWRC (3.54 S.F.) 33,600-LBS. BREAKING STRENGTH 9/16" - SPIN RESISTANT (54 S.F.) 45,900-LBS. BREAKING STRENGTH
DEDUCTIONS FROM RATED LOADS FOR HANDLING DEVICES SUPPLIED BY ELLIOTT EQUIPMENT CO. OVERHAUL BALL - - - - - SEE OVERHAUL BALL MFR. NAMEPLATE LOAD BLOCK - - - - - SEE BLOCK MFR. NAMEPLATE SWING AROUND JIB - - - - - SEE LOAD RATING CHART			
WARNING: LIFTING OFF THE MAIN BOOM WHILE JIB IS ERECTED IS NOT INTENDED OR APPROVED.			

MAIN BOOM LOAD RATINGS								JIB LOAD RATINGS										
LOAD RATINGS IN LBS. WITH OUTRIGGERS AND STABILIZERS EXTENDED								LOAD RATINGS IN LBS. WITH OUTRIGGERS AND STABILIZERS EXTENDED										
LOAD RADIUS IN FEET	LOADED BOOM ANGLE	22-FT.	LOADED BOOM ANGLE	A 32-FT.	LOADED BOOM ANGLE	B 40-FT.	LOADED BOOM ANGLE	C 48-FT.	LOADED BOOM ANGLE	D 56-FT.	6-FT. FIXED LENGTH JIB	6-FT. LOADED BOOM ANGLE	18-FT. FIXED LENGTH JIB	18-FT. LOADED BOOM ANGLE	18-30 FT. EXTENDABLE JIB	18-30 FT. EXTENDABLE JIB		
5	75	20000									80	4500	80	2900	80	2800	80	1900
10	62	11500	71	10500	75	9500					75	4000	75	2400	75	2300	75	1600
15	46	8000	62	7300	68	6700	72	6100	75	5600	70	3500	70	2000	70	1900	70	1300
20	20	5600	51	5400	60	5100	65	4800	69	4500	65	3000	65	1700	65	1600	65	1050
25			38	4200	51	4000	59	3800	64	3600	60	2700	60	1500	60	1400	60	900
30			17	3400	41	3300	51	3200	58	3000	55	2400	55	1200	55	1100	55	800
35					28	2800	43	2700	51	2500	50	2100	50	1100	50	1000	50	650
40							33	2200	44	2100	45	1800	45	950	45	850	45	550
45							18	1900	36	1800	40	1500	40	850	40	750		
50										26	1500							
55										4	1200							
0	4500	0	2800	0	2000	0	1500	0	1200	0	900							
											DEDUCTIONS FOR STOWED FIXED LENGTH JIB							
											DEDUCTIONS FOR STOWED EXTENDABLE JIB							
											DEDUCTIONS FOR STOWED EXTENDABLE JIB							

- WARNING**
- THE OPERATOR MUST READ AND UNDERSTAND ALL DECALS IN ADDITION TO THE OPERATION AND SAFETY MANUAL BEFORE OPERATING THIS CRANE.
 - POSITIONING OR OPERATION OF CRANE BEYOND AREAS SHOWN ON THIS CHART IS NOT INTENDED OR APPROVED EXCEPT WHERE SPECIFIED IN THE OPERATION AND SAFETY MANUAL.
 - LOADED BOOM ANGLES AT SPECIFIED BOOM LENGTHS GIVE ONLY AN APPROXIMATION OF THE OPERATING RADIUS. THE BOOM ANGLE BEFORE APPLYING A LOAD SHOULD BE GREATER TO ACCOUNT FOR DEFLECTION. DO NOT EXCEED THE OPERATING RADIUS FOR A BOOM LENGTH AND LOAD RATING.
 - THE JIB LOAD RATING CHART IS BASED ON THE LOADED BOOM ANGLES OF THE MAIN BOOM AND NOT THE LOAD RADIUS. DO NOT EXCEED JIB LOAD RATINGS AT REDUCED BOOM LENGTHS.
 - FOR BOOM ANGLES NOT SHOWN ON JIB LOAD RATING CHART, USE RATING OF NEXT LOWER BOOM ANGLE.
 - FOR BOOM LENGTHS NOT SHOWN, USE THE RATING OF NEXT LONGER BOOM LENGTH. FOR RADII NOT SHOWN, USE RATING OF NEXT LONGER RADIUS.
 - CRANE LOAD RATINGS ON OUTRIGGERS AND STABILIZERS ARE BASED ON FREELY SUSPENDED LOADS WITH THE MACHINE LEVELED AND STANDING ON A FIRM UNIFORM SUPPORTING SURFACE. NO ATTEMPT SHALL BE MADE TO MOVE A LOAD HORIZONTALLY TO THE GROUND IN ANY DIRECTION.
 - PRACTICAL WORKING LOADS DEPEND ON THE SUPPORTING SURFACE, WIND, AND OTHER FACTORS AFFECTING STABILITY SUCH AS HAZARDOUS SURROUNDINGS, EXPERIENCE OF PERSONNEL, AND PROPER HANDLING, ALL OF WHICH MUST BE TAKEN INTO ACCOUNT BY THE OPERATOR.
 - THE MAXIMUM LOAD WHICH MAY BE TELESCOPED IS LIMITED BY HYDRAULIC PRESSURE, BOOM ANGLE, AND BOOM LUBRICATION. IT IS SAFE TO ATTEMPT TO TELESCOPE ANY LOAD WITHIN THE LIMITS OF THE LOAD RATING CHART. BOOM MUST BE FULLY RETRACTED AGAINST THE BOOM STOPS AT ALL TIMES WHEN LIFTING MINIMUM BOOM LENGTH CAPACITY LOADS.
 - IF ANY OPERATIONAL AID SUCH ANTI-2-BLOCK, OVERLOAD SYSTEM OR LEVELING INDICATOR IS MALFUNCTIONING OR INOPERATIVE, DISCONTINUE USE IMMEDIATELY AND CONTACT A QUALIFIED REPAIR FACILITY.
 - CAPACITY INDICATING/LIMITING DEVICES SHOULD NOT BE RELIED UPON TO REPLACE THE USE OF CAPACITY CHARTS AND PROPER OPERATING PROCEDURES.

- INFORMATION**
- DEDUCTIONS MUST BE MADE FROM RATED CAPACITIES FOR STOWED JIB, OPTIONAL ATTACHMENTS, HOOKS, LOAD BLOCKS (SEE DEDUCTION CHART), WEIGHTS OF SLINGS AND ALL OTHER LOAD HANDLING DEVICES SHALL BE CONSIDERED A PART OF THE LOAD.
 - CRANE LOAD RATINGS WITH OUTRIGGERS AND STABILIZERS EXTENDED AND SET WITH ALL LOAD REMOVED FROM CARRIER WHEELS.
 - LOAD RATINGS ABOVE THE BOLD LINE ARE STRUCTURALLY LIMITED AND DO NOT EXCEED 85% OF TIPPING.

- DEFINITIONS**
- OPERATING RADIUS IS THE HORIZONTAL DISTANCE FROM THE CENTER OF ROTATION TO THE CENTER OF THE VERTICAL HOIST LINE OR TACKLE WITH A LOAD APPLIED.
 - LOADED BOOM ANGLES, SHOWN ABOVE, ARE THE INCLUDED ANGLE BETWEEN THE HORIZONTAL AND LONGITUDINAL AXIS OF THE BOOM BASE AFTER LIFTING RATED LOAD AT THE RATED RADIUS.

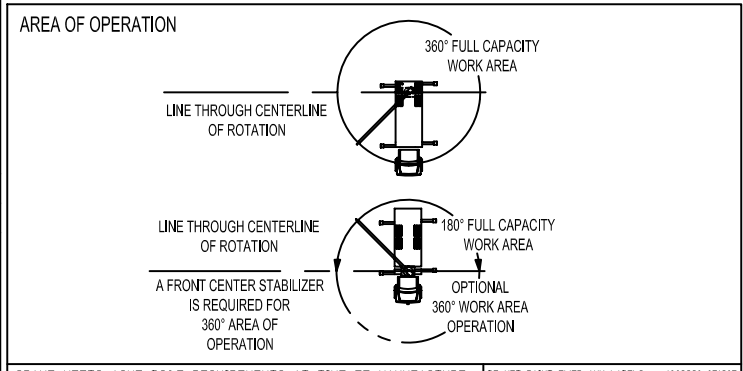

CHASSIS SPECIFICATIONS

	1056F BoomTruck
Wheelbase (WB)	211" / 536 cm
Cab to Axle (CA)	144" / 366 cm
Cab to End of Frame (EOF)	244" / 620 cm
Frame Section Modulus	10.0 in3-110,000 psi / 758,428 kPa
Front Axle Gross Weight Rating	13,000 lb / 5,896 kg
Rear Axle Gross Weight Rating	20,000 lb / 9,072 kg
Integral Front Frame Rails	Required for Front Stabilizer

Chassis data is minimum general requirements-not for engineering.
 Actual dimensions and truck data will depend on truck selection and axle configuration.
 *Minimum chassis weight is required to meet 85% stability requirements.

OPTIONS



Radio Remote Control

Interference protected radio remotes let you get closer to your work and have full control over your machine.



Pin-On Jib Attachments

Choose between telescopic or fixed jibs that stow on the side of the boom and pin on the boom tip for easy placement while on the worksite.



Continuous Boom Rotation

Add the convenience of 360 degree area of operation by adding a special boom rotation bearing for swinging without stops.



Superlink Short Jack Outriggers

Reduce your outrigger spread with Elliott's patented Superlink outriggers that allow straight down outrigger deployment on one side and full crane operation on the other.



Tool Boxes

Optional tool boxes and bed storage can accommodate any storage need for tools, work materials and more.

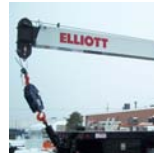

Hook Block for Multi-Part Line

Elliott can install a 2-3 part hook block to improve lifting capabilities. The block can be stored at the rear of the bed.



Gravity Levelled Basket

Elliott's pin-on work platform pins onto the boom for easy installation and removal. Gravity leveling and mechanical rotation makes it a great accessory for any worksite.



Body Mounted Hose Reels and Circuits

Let us work with you to customize your tool compatibility by adding hose reels or hydraulic circuits to the crane bed.