



Rough Terrain Telescopic Boom Material Handler



FEATURES

- **6,000 lb. (2722 kg) capacity**
27 ft. (8.2 m) reach
44 ft. (13.4 m) of lift
- ISO mounted canopy
- Smooth three section roller boom
- One high quality joy stick controller handles all boom and fork functions
- Self-leveling forks with no separate slave cylinder
- Fast, responsive high angle steering
- Dual sway and rear axle lockup cylinders
- Pressure compensated on-demand hydraulics, 10 micron filtration
- Motion control valves in the lift, boom, fork and sway circuits
- Turbo-charged diesel engine, 3-speed Powershift transmission
- 4-wheel drive, 4-wheel (2-wheel & oblique) power steering
- Oil cooled totally enclosed service brakes
- Spring applied, hydraulic release parking brake
- Planetary axles front and rear, 1300 x 24 12-ply tires
- Removable gauge panel
- SAE O-ring or JIC hydraulic connections

simple, available and
cost effective™

TEREX TH644C SPECIFICATIONS

WEIGHTS with Boom retracted and down	
On Front Axle	7,980 lbs. (3619 kg)
On Rear Axle	14,100 lbs. (6394 kg)
TOTAL	22,080 lbs. (10 013 kg)
DIMENSIONS with Boom retracted and down	
Width OVERALL	8' 6" (2.59 m)
Height OVERALL	8' 11" (2.72 m)
Length OVERALL	23' 10" (7.26 m)
Wheel Base	10' 10" (3.30 m)
Ground Clearance	1' 5" (.43 m)
Turning Radius (outside tire)	14' 9" (4.50 m)
ENGINE	
Make	John Deere Turbo-charged
Model	4045T
Power	99 HP (73.8 kW)
RPM	2500
Fuel Tank Capacity	30 Gals. (113.6 L)
TRANSMISSION	
Powershift/Converter	3 Speed
BRAKES - Parking	
Type	Spring Applied, Hydraulic Release
Location	Front Axle Input Shaft
BRAKES - Service	
Type	Enclosed, Hydraulic, Multiplate, Oil Cooled
Location	Internal
AXLES	
	Heavy Duty Steering Planetaries
WHEELS AND TIRES (Interchangeable)	
Wheels	Heavy Duty
Tires - Calcium Chloride Solution Filled	1300 x 24 - 12 Ply
TRAVEL SPEEDS - Forward and Reverse	
First	3.2 MPH (5.1 km/hr)
Second	6.9 MPH (11.1 km/hr)
Third	17.2 MPH (27.7 km/hr)
STEERING	
Power Hydraulic Modes	Hydrostatic 2 Wheel, 4 Wheel & Oblique
HYDRAULICS	
Single Pump (unloaded during engine start)	Axial Piston
Type	Flow on Demand
Filtration	10 Micron
Reservoir Capacity	34 Gals. (128.7 L)
SWAY CONTROL - Frame Leveling	
Type	Twin, Circuit Isolated, Cylinders
Range	10° Either Side of Center
EXTENSION BOOM	
	3 Section Roller
AUTOMATION	
Type	Hydromechanical
Operation	One Controllor
Fork Function	Self-leveling Throughout Lift/Lower Cycles and No Separate Slave Cylinder
FRAME STABILIZATION	
Type	Rear Axle Lock-up
Operation	Twin cylinders mounted between frame and axle actuated by stepping on service brake, shutting engine off, or 60° boom angle

For more information, product demonstration, or details on lease and rental plans, please contact your local Terex Construction Distributor.

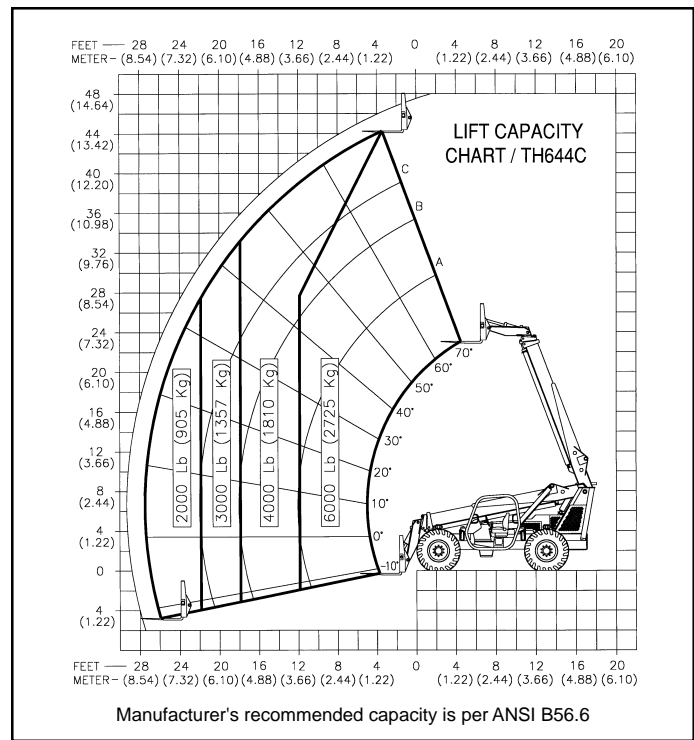

STANDARD EQUIPMENT

Single controller for all boom and fork functions • Heavy duty 3 section boom • Self-leveling fork frame • 2" x 4" x 48" (5.1 cm x 10.2 cm x 1.22 m) forks • Motion control valves in the lift, fork, extend and frame leveling circuits • Pilot operated on-demand hydraulics • 10 micron return hydraulic filter • 99 HP John Deere Turbo-charged diesel engine • Dry type air cleaner • Dirt and water fuel filtration • 31.5 (1,000 CCA @ 0°F) battery • 95 AMP alternator • 3 speed Powershift transmission with a service brake and parking brake activated clutch cutoff • 2 heavy duty steering planetary axles • 4 wheel (2 wheel & oblique) power steering • 1300 x 24 12-ply tires • Enclosed multiplate oil-cooled service and parking brakes / accumulator backup • 10° either side of center frame leveling with indicator • Lockable fuel and hydraulic tank caps • Hourmeter • Removable gauge panel • Gauges for: fuel level, transmission oil temperature, transmission clutch pressure, engine oil pressure, engine coolant temperature and electrical system voltage • Keyed start switch • Adjustable upholstered seat with seat belt • Back up alarm and rear view mirror • Hydraulic pressure connections are SAE O-ring or JIC • Pins are hardened and ground • Bushings are of high compressive strength material • Hardware is grade 8 • ISO mounted canopy

OPTIONAL EQUIPMENT

Fully enclosed cab • Dual joystick controls • Heater • Defroster fan • Wiper • Turn signal & hazard flasher package • Cubing tines • Rubbish bucket (1 yard) • 60" and 72" (1.52 m and 1.83 m) pallet forks • 60" – 72" (1.52 m – 1.83 m) wide fork frame • 48", 60", and 72" (1.22 m, 1.52 m, and 1.83 m) rotating fork frames • 45° Swing fork frame 60" and 72" (1.52 m and 1.83 m) • Variable reach truss boom • Lights: Headlights, brake, tail, rear flood and strobe • Foam-filled tires • Severe duty tires • Cummins B3.9 C-99 Turbo-charged diesel engine • Quik-Switch Attachment • Auxiliary hydraulics • Suspension seat • Front window • Front screen • Right hand sliding window • Ether aid • Block heater • Front axle differential lock

We reserve the right to amend these specifications at any time without notice. The only warranty applicable is our standard written warranty applicable to the particular product and sale. We make no other warranty, expressed or implied.



TEREX CONSTRUCTION AMERICAS

455 N. Superior Ave. • Baraga, MI 49908-0790 USA

906-353-6675 • Fax: 906-353-7543

E-mail: thsales2@up.net

www.terex.com