

COLES Illustrious Truck

B.S. 1767 RATING

GENERAL

The Coles Illustrious is a truck-mounted, diesel-electric, fully slewing crane on an 8 x 4-wheel drive chassis fitted with telescopic outrigger beams, fully sprung front axles and articulated rear bogie.

The diesel engine on the slewing superstructure is directly coupled to a variable speed generator which energises the electric motors of the hoist, derrick and slew motions. Direct current is supplied to the motors at a potential which can be varied at will from zero to maximum.

Each crane motion is controlled by an interlocked pair of heavy duty reversing contactors operated by pilot switches in the operator's cab. Coles advanced control system and built-in safety devices automatically safeguard the machine and load. The operator can select any motion, irrespective of the engine speed, whereupon the electrical equipment introduces the motion without shock to electrical or mechanical components. No restraint is placed upon the crane operator, enabling the optimum operating cycle to be achieved.

The chassis is specially designed for crane service, combining maximum stability for lifting duties with excellent travel performance. Drive to the rear bogie is taken from a chassis-mounted diesel engine via a multi-speed gearbox and two-ratio auxiliary gearbox.

GENERAL DATA

Maximum Negotiable Gradient—1 in 2.4 (42%)

Maximum Drawbar Pull—40,000 lb. (18140 kg).

Turning Radius—45' 0" (13.72 m) kerb to kerb.

Approximate Weight—42.68 tons (43345 kg).

Fuel Tank Capacity—32 gallons (145 litres) supplying superstructure engine, 59 gallons (268 litres) supplying chassis engine.

OPERATING SPEEDS

Hoisting—5 tons (5000 kg) at 160 f.p.m. (49 m.p.m.) on single line. Light line at 280 f.p.m. (85 m.p.m.).

Derricking—maximum to minimum radius in 40 seconds with 25' 0" (7.62 m) jib.

Slewing—3 r.p.m. unladen.

Travelling—28 m.p.h. (45 k.p.h.).

CRANE DATA

Engine—Ford 2704E diesel, developing 92 h.p. at 2000 r.p.m. The engine speed is controlled by a foot throttle in the operator's cab. An engine hour meter is fitted and a semi-rotary fuel pump is provided. **Motors and Generator**—specially designed as matched machines for crane service. The variable voltage, variable speed generator has an output of 0 - 400 volts. The three variable voltage motors have maximum outputs of 78 h.p. hoist, 65 h.p. derrick, and 32 h.p. slew. **Brakes**—electro-mechanical, automatically applied brakes are fitted to hoist, derrick and slew motions, with dynamic braking on lowering motion. The shoes are spring applied and released by a continuously rated solenoid coil. **Operator's Cab**—totally enclosed, full vision type with safety glass windows, one sliding window, windscreen wiper, anti-glare roof window, adjustable seat and lockable door. The control switches are located at the sides of the operator's seat for maximum ease of operation. **Safe Load Indicator**—provides visual and audible warning of approaching overload, and halts the hoisting and derricking-out motions automatically at a predetermined overload. **Limit Switches**—totally enclosed, automatically self-resetting type, fitted to the hoist motion to prevent overwinding and over-

various radii. **Jib**—strut type, pin jointed, lattice construction, 25' 0" (7.62m) between centres. (see Optional Equipment for additional jib lengths). Jib provided with gentry mast and minimum radius jib stops. **Electrical Equipment**—12 volt starting equipment, electric horn and lighting. **Slew Ring**—large diameter double live ring of steel balls running in hardened races. **Ballast**—removable cast iron ballast weight bolted to rear of superstructure.

CHASSIS DATA

General—specially designed for crane service and fabricated from high tensile rolled steel beams and plates. The frame houses four telescopic girder outriggers fitted with screw jacks. **Engine**—A.E.C. AV780 diesel, developing 217 b.h.p. at 2000 r.p.m. Maximum torque 618 lb. ft. (85 kg.m) at 1600 r.p.m. **Ballast Removal Gear**—hydraulically operated, chassis-mounted lifting gear for easy removal of ballast to facilitate road travel at maximum transit speeds. **Wheels and Tyres**—13.00 x 20 pneumatics, singles front, twins rear. **Tyre Pump**—power operated. **Brakes**—air operated dual-line brakes acting on all wheels. Multiple-diaphragm brake chambers on rear axles incorporate lock actuators for parking. Engine fitted with exhaust brake. **Clutch**—single dry plate with servo-assisted release mechanism. **Gearbox**—6 forward speeds and one reverse. Integral two-ratio auxiliary gearbox. **Front Axles**—tandem axles mounted on equalised semi-elliptic leaf springs. **Steering**—cam and double roller type with hydraulic power assistance. **Rear Bogie**—tandem axles with fully articulated rocking beam suspension. Double reduction drive through worm and hub gearing, plus inter-axle differential with clutch-operated locking-out mechanism. **Driver's Cab**—full width, forward mounted 'Roadcruiser' cab with adjustable driver's seat, hydraulically damped against road shocks, and upholstered seats for up to three crew. Windscreen wipers, driving mirrors and full instrumentation is provided. **Electrical Equipment**—24 volt lighting and starting equipment with electric horn, instrument panel and dashlight, two twin unit headlamps, two side and two rear lamps and flashing direction indicators. **Toolbox**—with complete tool kit.

OPTIONAL EQUIPMENT

Jib Extensions—5' 0" (1.52m) used only with 30' 0" (9.14m) jib; 10' 0" (3.05m), 15' 0" (4.57m), 20' 0" (6.10m) and 30' 0" (9.14m) extensions for jibs up to a maximum length of 170' 0" (51.80m). **Fly Jib**—two-piece 20' 0" (6.10m) centres. **Fly Jib Extension**—20' 0" (6.10m) centres. **Auxiliary Tie Ropes**—for self-erection of jibs 140' 0" (42.70m) in length and over. **Single Hook and Pearweight**. **Three-Part Snatchblock**. **Powered Hoist Drum**—additional independently driven unit for use with fly jib and including dynamic braking on lowering motion; giving 5.0 ton (5080 kg) at 150 f.p.m. (45.70 m.p.m.) on single fall; light line at 240 f.p.m. (73.10 m.p.m.) 'Free' Hoist Drum—free-running drum with air clutch and brake. **Tandem 'Free' Hoist Drums**—dual free-running drums with air clutches and brakes. **Tropical Cabs**—with fan and opening windows, on superstructure and chassis. **Arctic Cabs**—with heater and glass fibre insulation, on superstructure and chassis. **Hydraulic Outriggers**—giving powered extension and lift. **Left Hand Drive Chassis**—fitted with removable outrigger housings. **Left Hand Drive Chassis**—fitted with hydraulic outriggers mounted in removable housings, and complete with elephant feet. **Perkins 6/354 Diesel Engine**—on superstructure. **Rear Swing-out Stabilizers**—for self-erection of jibs (with fly if applicable) 140' 0" (42.70m) in length

AXLE LOADING

To conform to local Highway Regulations regarding axle loading, adjustments may be made to the total crane weight, according to the following table. Using Item 1 as the basic crane weight, deduct 'minus' figures or add 'plus' figures as shown.

Item No.	EFFECT OF REMOVING THE FOLLOWING EQUIPMENT FROM ITEM 1	JIB OVER FRONT OF CHASSIS				JIB OVER REAR OF CHASSIS				TOTAL WEIGHT OR ADJUSTMENT	
		Front Axles		Rear Bogie		Front Axles		Rear Bogie		Tons	kg
		Tons	kg	Tons	kg	Tons	kg	Tons	kg	Tons	kg
1	Complete Standard Machine with 1.75 ton (1778 kg) Hoist Ballast, 2.30 ton (2335 kg) Fixed Ballast, 5.2 ton (5280 kg) Removable Ballast in stowed position, and 25' 0" (7.62 m) Jib in travel position with Snatchblock stowed.	16.84	16095	28.82	27250	17.35	17630	26.31	25715	42.68	43346
2	Ballast complete	- 4.18	- 4245	- 1.02	- 1040	- 4.18	- 4245	- 1.02	- 1040	- 5.20	- 5285
3	25' 0" (7.62 m) Basic Jib complete with Tie Ropes, Equalising Gear, Gantry Mast and Jib Head Tackle	- 2.98	- 3030	+ 0.77	+ 785	+ 2.28	+ 2315	- 4.49	- 4560	- 2.21	- 2245
4	10' 0" (3.05 m) Head Section and Jib Head Tackle	- 1.60	- 1625	+ 0.74	+ 750	+ 1.33	+ 1350	- 2.19	- 2225	- 0.88	- 875
5	15' 0" (4.57 m) Foot Section with Gantry Mast and Equalising Gear	- 1.38	- 1405	+ 0.03	+ 35	+ 0.96	+ 965	- 2.30	- 2335	- 1.35	- 1370
6	Front Outrigger Beams - Manual	- 0.47	- 475	- 0.33	- 335	- 0.47	- 475	- 0.33	- 335	- 0.80	- 810
7	Rear Outrigger Beams - Manual	+ 0.27	+ 275	- 1.07	- 1085	+ 0.27	+ 275	- 1.07	- 1085	- 0.80	- 810
8	Front Outrigger Beams - Hydraulic	- 0.71	- 720	- 0.49	- 500	- 0.71	- 720	- 0.49	- 500	- 1.20	- 1220
9	Rear Outrigger Beams - Hydraulic	+ 0.42	+ 425	- 1.82	- 1845	+ 0.42	+ 425	- 1.82	- 1845	- 1.20	- 1220
10	Front Outrigger Housings and Beams - Manual	- 0.90	- 915	- 0.65	- 660	- 0.90	- 915	- 0.65	- 660	- 1.55	- 1575
11	Rear Outrigger Housings and Beams - Manual	+ 0.67	+ 680	- 2.57	- 2610	+ 0.67	+ 680	- 2.67	- 2610	- 1.90	- 1930
12	Front Outrigger Housings and Beams - Hydraulic	- 1.10	- 1120	- 0.80	- 810	- 1.10	- 1120	- 0.80	- 810	- 1.80	- 1830
13	Rear Outrigger Housings and Beams - Hydraulic	+ 0.70	+ 710	- 2.70	- 2745	+ 0.70	+ 710	- 2.70	- 2745	- 2.00	- 2035
14	Derrick Rope	- 0.08	- 80	- 0.08	- 80	+ 0.03	+ 30	- 0.19	- 190	- 0.18	- 160
15	Hoist Rope	- 0.09	- 90	- 0.16	- 165	+ 0.01	+ 10	- 0.28	- 265	- 0.25	- 255
16	Snatchblock	- 0.64	- 650	0	0	- 0.64	- 650	0	0	- 0.64	- 650
Item No.	EFFECT OF ADDING THE FOLLOWING OPTIONAL EQUIPMENT TO ITEM 1										
17	Rear Stabilizers	- 0.13	- 130	+ 0.43	+ 435	- 0.13	- 130	+ 0.43	+ 435	+ 0.30	+ 306
18	Single Free Hoist Drum	0	0	+ 0.50	+ 510	+ 0.18	+ 165	+ 0.34	+ 345	+ 0.50	+ 510
19	Tandem Free Hoist Drums including removal of Hoist Ballast										
20	Twin Motor Hoist Drums including removal of Hoist Ballast	- 0.05	- 50	- 0.40	- 405	- 0.10	- 100	- 0.36	- 355	- 0.46	- 455
21	Hydraulic Outriggers including removal of 1 ton (1015 kg) Fixed Ballast	+ 0.51	+ 515	- 0.38	- 365	- 0.54	- 550	+ 0.89	+ 700	+ 0.15	+ 150
22	Removable Housings	+ 0.08	+ 80	+ 0.62	+ 630	+ 0.08	+ 80	+ 0.62	+ 630	+ 0.70	+ 710
23	Outrigger Feet (Manual Outriggers)	+ 0.01	+ 10	+ 0.09	+ 90	+ 0.01	+ 10	+ 0.09	+ 90	+ 0.10	+ 100
24	Auxiliary Hoist Rope	+ 0.06	+ 50	+ 0.18	+ 185	+ 0.02	+ 20	+ 0.21	+ 215	+ 0.23	+ 235

The following axle and bogie loads must not be exceeded for highway travel — Front axles (total), 16.50 tons (16760 kg).
Rear bogie (total), 31 tons (31500 kg).

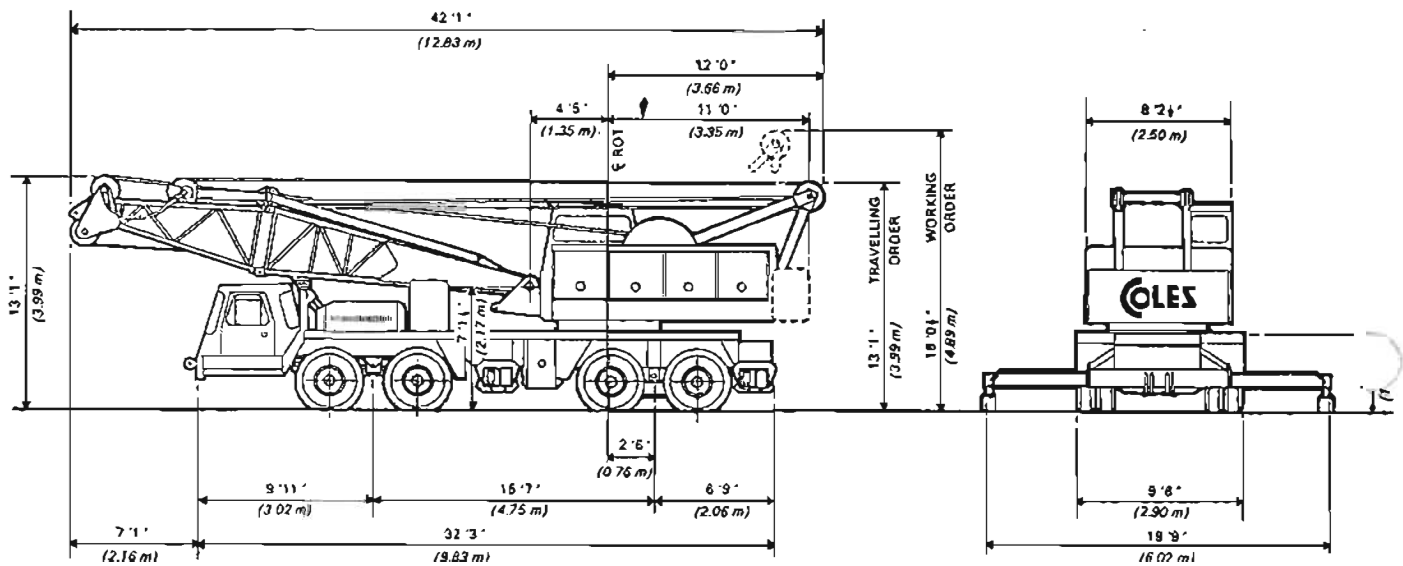

MAIN JIB CAPACITIES OVER SIDE AND REAR IN TONS

Radius in Feet	26' 0" JIB		40' 0" JIB		60' 0" JIB		80' 0" JIB		70' 0" JIB		80' 0" JIB		90' 0" JIB		100' 0" JIB		110' JIB	120' JIB	130' JIB	140' JIB	160' JIB	180' JIB	170' JIB	
	Blkd	Free	Blkd	Free	Blkd	Free	Blkd	Free	Blkd	Free	Blkd	Free	Blkd	Free	Blkd	Free	Blkd	Blkd	Blkd	Blkd	Blkd	Blkd	Blkd	
13' 0"	40.00	13.60																						
15' 0"	33.50	11.30	33.00	11.20	32.00	11.10	28.00	11.00																
20' 0"	24.00	7.90	23.75	7.80	23.50	7.75	22.50	7.70	21.50	7.65	20.00	7.60												
25' 0"	18.00	6.80	17.80	5.70	17.60	5.65	17.40	5.60	17.20	5.55	17.00	5.50	16.50	5.40	14.50	5.30	12.50							
30' 0"			14.50	4.40	14.40	4.35	14.30	4.30	14.20	4.25	14.10	4.20	13.75	4.10	13.00	4.00	12.00							
35' 0"			11.30	3.60	11.20	3.55	11.10	3.50	11.00	3.40	10.90	3.30	10.75	3.20	10.50	3.10	10.20	9.00	8.00					
40' 0"			9.20	2.90	9.10	2.85	9.00	2.80	8.90	2.70	8.80	2.60	8.70	2.50	8.60	2.40	8.40	8.20	7.70	6.50	5.50	4.50	4.00	3.50
50' 0"					8.30	2.00	8.20	1.95	8.15	1.90	8.10	1.80	8.05	1.70	8.00	1.60	5.90	5.80	5.70	5.60	5.00	4.30	3.70	3.20
60' 0"							4.70	1.40	4.65	1.30	4.60	1.25	4.55	1.16	4.50	1.06	4.45	4.40	4.30	4.25	4.25	4.00	3.50	3.00
70' 0"									3.80	0.95	3.65	0.85	3.50		3.35		3.40	3.35	3.30	3.30	3.25	3.20	3.00	2.50
80' 0"											2.90		2.85		2.75		2.70	2.65	2.60	2.60	2.55	2.50	2.40	2.00
90' 0"													2.25		2.20		2.18	2.10	2.06	2.04	2.00	1.95	1.90	1.50
100' 0"															1.75		1.70	1.65	1.60	1.60	1.55	1.50	1.45	1.00
110' 0"																	1.55	1.60	1.36	1.30	1.25	1.20	1.15	0.75
120' 0"																		1.30	1.15	1.00	0.96	0.90	0.85	0.50

FLY JIB CAPACITIES OVER SIDE AND REAR IN TONS

Radius in Feet	80' 0" Jib + 20' 0" Fly	80' 0" Jib + 40' 0" Fly	80' 0" Jib + 60' 0" Fly	100' 0" Jib + 20' 0" Fly	100' 0" Jib + 40' 0" Fly	100' 0" Jib + 60' 0" Fly	130' 0" Jib + 20' 0" Fly	130' 0" Jib + 40' 0" Fly	130' 0" Jib + 60' 0" Fly	130' 0" Jib + 80' 0" Fly	150' 0" Jib + 20' 0" Fly	150' 0" Jib + 40' 0" Fly	150' 0" Jib + 60' 0" Fly	150' 0" Jib + 80' 0" Fly	Radius in Feet
	Blkd	Blkd	Blkd	Blkd	Blkd	Blkd	Blkd	Blkd	Blkd	Blkd	Blkd	Blkd	Blkd	Blkd	
30' 0"	12.00														30' 0"
35' 0"	10.20	8.10		8.80											35' 0"
40' 0"	8.50	7.30	6.50	7.70	6.30		5.00				3.90				40' 0"
45' 0"	7.00	6.70	6.00	6.80	5.80	5.00	4.65	4.00			3.75	3.30			45' 0"
50' 0"	6.30	6.00	5.50	5.80	5.30	4.75	4.30	3.90	3.00		3.70	3.00			50' 0"
55' 0"	5.10	5.50	5.10	5.00	4.80	4.40	4.00	3.70	2.80	2.40	3.40	2.90			55' 0"
60' 0"	4.50	4.60	4.70	4.40	4.40	4.10	3.70	3.50	2.65	2.30	3.15	2.80	1.70	1.05	60' 0"
70' 0"	3.45	3.60	3.70	3.35	3.50	3.50	3.10	2.90	2.40	2.10	2.70	2.40	1.60	0.90	70' 0"
80' 0"	2.75	2.90	3.00	2.85	2.70	2.80	2.40	2.50	2.20	1.90	2.20	2.10	1.30	0.80	80' 0"
90' 0"	2.20	2.30	2.40	2.00	2.20	2.30	1.85	2.00	1.80	1.70	1.75	1.70	1.10	0.70	90' 0"
100' 0"	1.75	1.90	2.00	1.65	1.70	1.80	1.45	1.60	1.55	1.45	1.30	1.40	1.00	0.65	100' 0"
110' 0"		1.50	1.60	1.30	1.40	1.50	1.10	1.25	1.30	1.25	1.00	1.10	0.80		110' 0"
120' 0"		1.25	1.30	1.00	1.10	1.20	0.80	0.95	1.00	1.00		0.80			120' 0"

IMPORTANT NOTE: The above imperial tables and the metric tables overleaf are not direct conversions of each other and must be used independently.

The above capacities are in accordance with British Standard 1757 (1984) Clause 11 — Stability.

The weight of the snatchblock, magnets, slings, equalising beams and all similarly used load handling devices must be added to the weight of the load.

Jib Erection—rear stabilizers must be used for the self-erection of jibs (with fly if applicable) 140' 0" in length and over. Auxiliary tie ropes must be fitted for jibs of 140' 0" in length and over.

Fly Jib—when a fly jib is fitted, the main hook capacities at the jib head must be reduced accordingly—see table

If a snatchblock is fitted to the main jib, the fly jib capacities must be reduced by the weight of the snatchblock.

SNATCHBLOCK CAPACITIES AND WEIGHTS (Tons)

Number of Falls	8	7	6	5	4	3	2	1
Maximum Load	40.00	35.00	30.00	25.00	20.00	15.00	10.00	5.00
Snatchblock Weight	0.64	0.64	0.61	0.61	0.58	0.25	0.26	0.14

FLY JIB DATA

Fly Jib Offset: 10° from centre line of main jib	
Fly Jib Centres	Reduction in Main Hook Duty
20' 0"	0.80 tons
40' 0"	1.20 tons
60' 0"	1.60 tons
80' 0"	2.00 tons

CLEAR OUTREACH According to position of jib

Position of Jib Relative to Chassis	Deduct from Radius	
	Blocked	Fully Mobile
Over Sides	9' 0"	4' 9"
Over Rear Corners	13' 0"	10' 4 1/2"
Over Rear	9' 3"	9' 3"

HEIGHT TO —
Add to hook
headroom ca

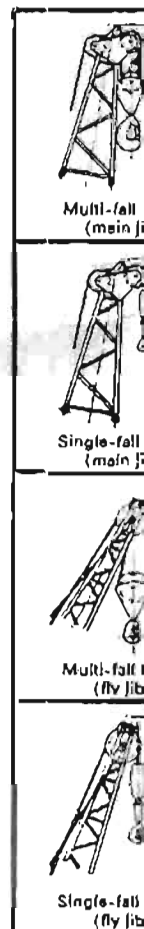

The above
25' 0" to

IN FEET

150' JIB	160' JIB	170' JIB	Radius in Feet
Blkd	Blkd	Blkd	12'0"
			16'0"
			20'0"
			25'0"
			30'0"
			35'0"
5.50	4.50	4.00	40'0"
6.00	4.30	3.70	50'0"
4.25	4.00	3.50	60'0"
3.25	3.20	3.00	70'0"
2.55	2.60	2.40	80'0"
2.00	1.95	1.90	90'0"
1.85	1.60	1.45	100'0"
1.25	1.20	1.15	110'0"
0.95	0.90	0.85	120'0"

HEIGHT TO JIB HEAD
Add to hook height for headroom calculations

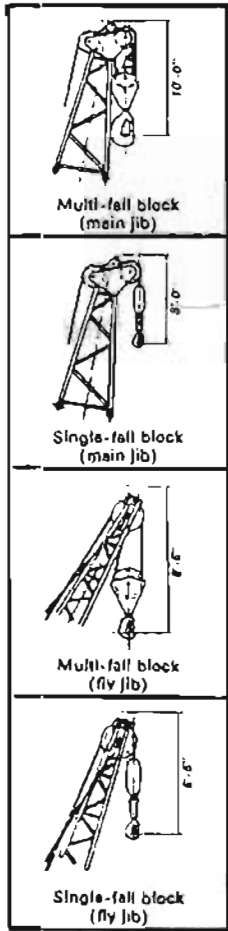

Q OF ROTATION

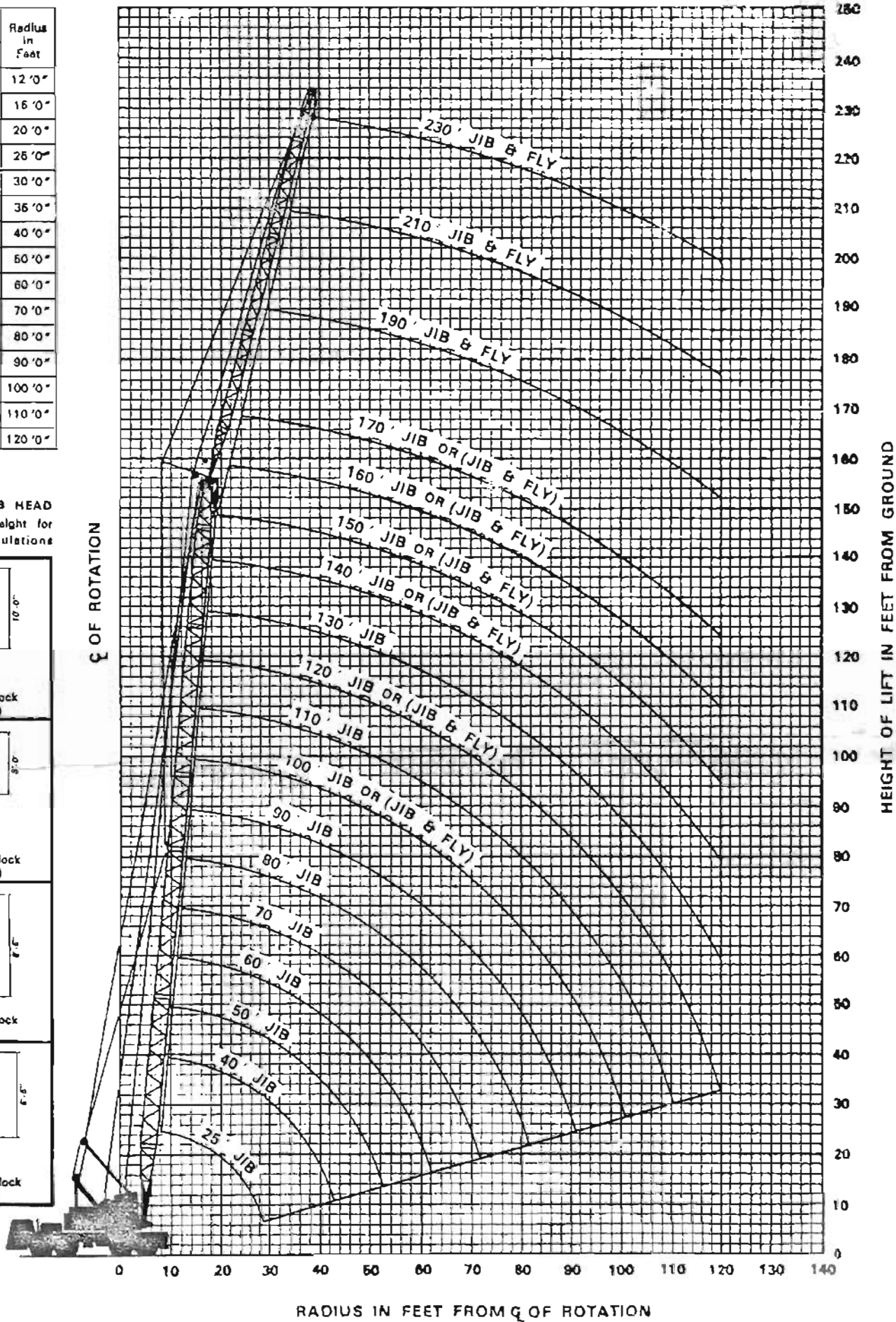

RADIUS IN FEET FROM Q OF ROTATION

The above heights of lift are for multi-fall snatchblocks on jibs from 25'0" to 150'0" and single-fall snatchblocks on jibs from 160'0"

to 230'0". Add 2'0" if single-fall block is used in place of multi-fall, or deduct 2'0" if multi-fall block is used in place of single-fall.