

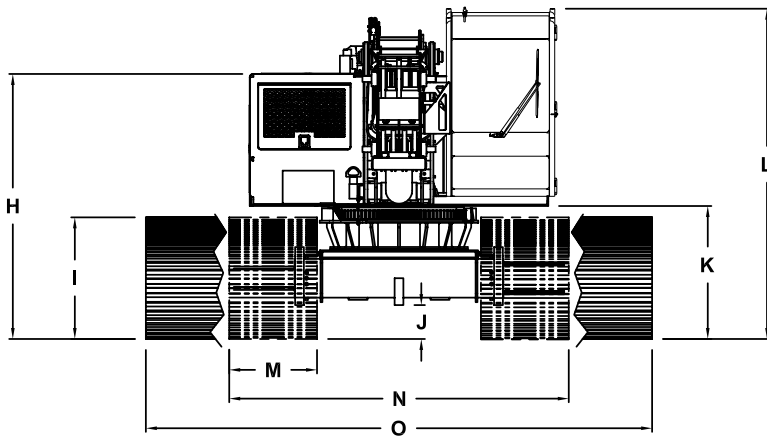

# SPECIFICATIONS

## MANTIS® 6010 30 TON TELE-BOOM CRAWLER CRANE

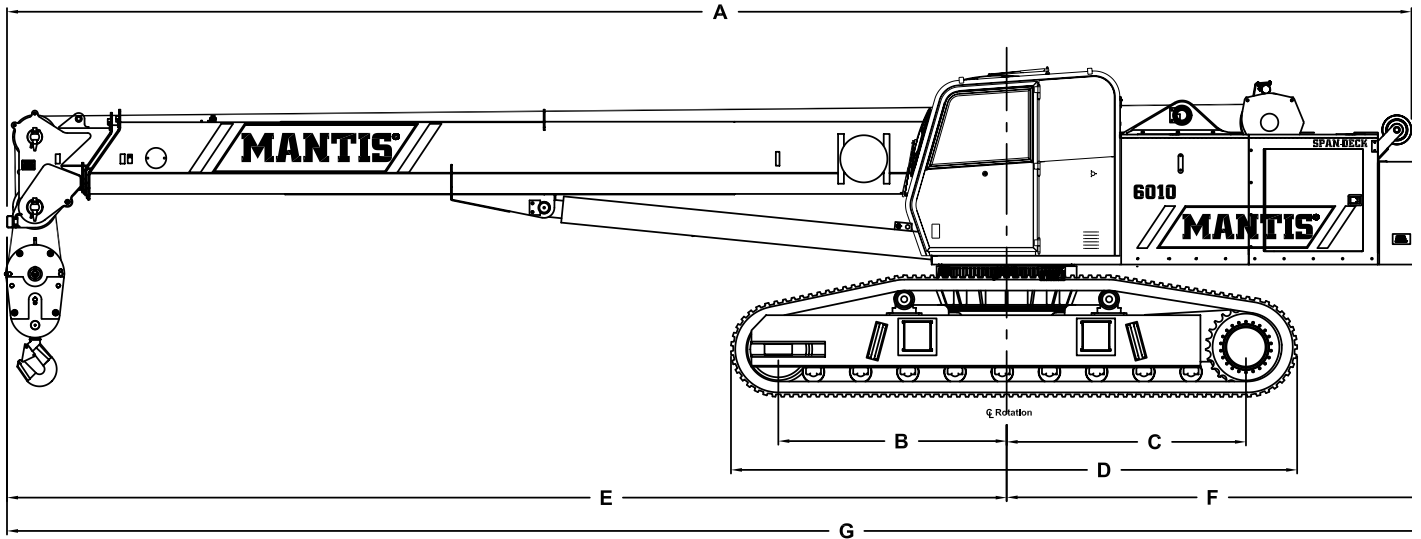

### PRINCIPAL DIMENSIONS

| Dimension | Description                         | Value                |
|-----------|-------------------------------------|----------------------|
| A         | Length (Counterweight Removed)      | 40 ft 2 in (12.24 m) |
| B         | CL Front Track Drive to CL Rotation | 80 in (2.03 m)       |
| C         | CL Rear Track Drive to CL Rotation  | 81 in (2.06 m)       |
| D         | Track Length                        | 16 ft 1 in (4.90 m)  |
| E         | Boom Length to CL Rotation          | 28 ft 6 in (8.69 m)  |
| F         | Tailswing                           | 12 ft 8 in (3.86 m)  |
| G         | Overall Length                      | 41 ft 1 in (12.52 m) |
| H         | Ground to Top of Engine Cover       | 90 in (2.29 m)       |
| I         | Track Height                        | 42 in (1.07 m)       |
| J         | Ground Clearance                    | 11 in (279 mm)       |
| K         | Ground to Bottom of Cab             | 46 in (1.17 m)       |
| L         | Maximum Overall Height              | 9 ft 6 in (2.90 m)   |
| M         | Track Width                         | 30 in (762 mm)       |
| N         | Overall Width (Tracks Retracted)    | 10 ft 2 in (3.10 m)  |
| O         | Overall Working Width               | 14 ft 6 in (4.42 m)  |

### WIDTHS, WEIGHTS, AND GROUND PRESSURES\*

| Shoe Width     | Overall Width       |                     | Area   | Ground Pressure                     | Working Weight        |
|----------------|---------------------|---------------------|--|-------------------------------------|-----------------------|
|                | Retracted           | Extended            |  |                                     |                       |
| 18 in (457 mm) | 8 ft 6 in (2.59 m)  | 13 ft 6 in (4.11 m) | 5,760 in <sup>2</sup> (3.72 m <sup>2</sup> ) | 10.5 psi (0.74 kg/cm <sup>2</sup> ) | 60,505 lb (27,445 kg) |
| 24 in (609 mm) | 9 ft 8 in (2.95 m)  | 14 ft 0 in (4.27 m) | 7,680 in <sup>2</sup> (4.95 m <sup>2</sup> ) | 8.0 psi (0.56 kg/cm <sup>2</sup> )  | 61,665 lb (27,971 kg) |
| 30 in (762 mm) | 10 ft 2 in (3.10 m) | 14 ft 6 in (4.42 m) | 9,600 in <sup>2</sup> (6.19 m <sup>2</sup> ) | 6.5 psi (0.46 kg/cm <sup>2</sup> )  | 62,820 lb (28,495 kg) |

\* Crane equipped with: 80 ft boom, extension, jib, 30 ton hook block, and 7 ton headache ball



# SPECIFICATIONS

## MANTIS® 6010 30 TON TELE-BOOM CRAWLER CRANE

### STANDARD CRANE AND EQUIPMENT

---

#### Boom

The boom consists of three full power sections. Retracted length is 32 ft 8 in (9.96 m) and extended length is 80 ft (24.38 m). Maximum tip height is 85 ft (25.91 m).

#### Boom Telescoping & Elevating Systems

The elevating system features a single cylinder and counterbalance lock valves which provides boom elevations from -1° to 78°.

The telescoping system features a single double-acting hydraulic cylinder and counterbalance lock valves.

#### Boom Head

Five 15 in (381 mm) diameter cast nylon sheaves on heavy-duty roller bearings are mounted in the boom head.

#### Load Moment Indicator & Anti-Two Block<sup>1</sup>

Standard Rated Capacity Limiter and Anti-Two Block system includes audio and video warnings and control function shutdown. System's LCD screen provides a continuous electronic display of working boom length, boom angle, working load radius, tip height, parts-of-line (operator set), machine track configuration, relative load moment, maximum permissible load and actual load. The standard Work Area Definition audio and video warnings aid the operator in avoiding job-site obstructions by pre-setting and defining the work area. The anti-two block weight allows quick reeving of hook blocks.

### SUPERSTRUCTURE

---

#### Frame

The frame is an all-steel, welded structure, precision machined to accept attachment of the boom and swing components.

#### Operator's Cab

The fully-enclosed, air conditioned all-steel modular cab includes a lockable swinging door, acoustical lining, anti-slip floor and tinted safety glass. Sliding windows are located in the cab door and cab boom side. A vent window is positioned in the rear of the cab. Grab bars and steps are appropriately located for easy access to the cab. Erectable swing barricades are attached to the superstructure. Rear view cameras are appropriately located as are work lights.

Standard cab accessories include a two-speed windshield wiper, top glass wiper, defroster, heater, circulating fan, adjustable hand and foot throttles, six-way adjustable fabric seat with headrest, seat belt, dome light, and a dry-chemical fire extinguisher.

#### Instrumentation

Dash instrumentation features a tachometer, voltmeter, oil pressure gauge, temperature gauge, hour meter and fuel gauge. Indicators are provided for crane level, load moment, drum rotation, air filter restriction, hydraulic oil temperature and filter restriction, engine oil pressure and temperature.

A termination switch is located in the seat and armrest and is capable of immediately disabling all hydraulic functions as the operator rises from the seat or it can be activated by lifting the left hand armrest.

#### Control

Two-way hydraulic joysticks mounted in the armrests of the operator's seat control swing, boom extend, main winch and boom hoist. Three two-way hydraulic foot pedals control the travel and swing service brake functions. Travel pedal hand levers are available as an option. A fourth pedal controls engine speed.

#### Counterweight

The 11,500 lb (5,220 kg) single piece counterweight can be removed and installed via a pendant attached to the boom.

#### Swing

The superstructure rotates 360° on an external gear shear ball slew bearing bolted to the superstructure and the carbody. The hydraulic swing drive powers the system and consists of a gear motor driving a planetary gear reducer with a shaft mounted pinion, providing infinitely variable speeds of up to 3 rpm.

Swing braking is achieved through a "failsafe", hydraulically released, spring applied, multi-disc brake which includes a foot applied service brake. Alternatively, the brake can be electrically actuated through a cab mounted switch into a "locked-on" (parking) mode. A two position house lock system is included. Regular lubrication of the bearing is achieved through a cab mounted grease applicator.

#### Fuel System

An 80 US gal (303 liter) tank is bolted to the superstructure. The fuel filtration system consists of an inline fuel/water separator as well as an engine mounted fuel filter.

#### Hydraulic System

The load sensing, open-loop hydraulic system is served by two variable volume pumps mounted in tandem. The pumps are torque limiting and pressure compensated providing a maximum output of 115 gpm (437 l/min) @ 2,200 rpm and maximum operating pressure of 4,850 psi (339.5 kg/cm<sup>2</sup>). An extra circuit is included for ready adaptation to hydraulic accessories.

The system includes two pilot operated valve banks that are pressure and flow compensated. The 150 US gal (568 liter) capacity hydraulic oil reservoir has a spin-on filler-breather cap, external sight gauge, clean-out access and a sump type drain. Hydraulic oil filtering is achieved with two 5 micron full flow cartridge type filters designed to return in-tank with bypass protection and an electronic bypass indicator.

(System pressure test ports with quick disconnect fittings are provided for diagnostic purposes.)



# SPECIFICATIONS

## MANTIS® 6010 30 TON TELE-BOOM CRAWLER CRANE

### MAIN HOIST

| Planetary geared single-speed winch includes a bent axis, variable displacement hydraulic motor and a multi-disc internal brake. Wire Rope: 600 ft (183 m) 9/16 in (14 mm) 6 x 37 EIPS, IWRC, RRL. Line pulls are not based on wire rope strength. Drum rotation indicator is standard. |                   |          |                      |            |                |          |        |        |        |         |
|---|-------------------|----------|----------------------|------------|----------------|----------|--------|--------|--------|---------|
| Rope Layer  | Maximum Line Pull |          | Full Load Line Speed |            | Pitch Diameter |          | Layer  |        | Total  |         |
| 1   | 11,000 lb         | 4,990 kg | 198 ft/min           | 60.4 m/min | 11.2 in        | 284.3 mm | 70 ft  | 21.4 m | 70 ft  | 21.4 m  |
| 2   | 10,000 lb         | 4,540 kg | 212 ft/min           | 64.6 m/min | 12.2 in        | 309.1 mm | 76 ft  | 23.3 m | 147 ft | 44.7 m  |
| 3   | 9,100 lb          | 4,130 kg | 221 ft/min           | 67.4 m/min | 13.1 in        | 333.9 mm | 83 ft  | 25.2 m | 229 ft | 69.9 m  |
| 4   | 8,400 lb          | 3,810 kg | 229 ft/min           | 69.8 m/min | 14.1 in        | 358.8 mm | 89 ft  | 27.1 m | 318 ft | 97.0 m  |
| 5   | 7,800 lb          | 3,540 kg | 244 ft/min           | 74.4 m/min | 15.1 in        | 383.6 mm | 95 ft  | 28.9 m | 413 ft | 125.9 m |
| 6   | 7,300 lb          | 3,310 kg | 247 ft/min           | 75.3 m/min | 16.1 in        | 408.4 mm | 101 ft | 30.8 m | 514 ft | 156.7 m |
| 7   | 6,800 lb          | 3,080 kg | 256 ft/min           | 78.0 m/min | 17.1 in        | 433.2 mm | 107 ft | 32.7 m | 621 ft | 189.4 m |

### AUXILIARY HOIST

| Planetary geared single-speed winch includes a bent axis, variable displacement hydraulic motor and a multi-disc internal brake. Wire Rope: 300 ft (91 m) 9/16 in (14 mm) 6 x 37 EIPS, IWRC, RRL. Line pulls are not based on wire rope strength. Drum rotation indicator is standard. |                   |          |                      |            |                |          |       |        |        |         |
|--|-------------------|----------|----------------------|------------|----------------|----------|-------|--------|--------|---------|
| Rope Layer   | Maximum Line Pull |          | Full Load Line Speed |            | Pitch Diameter |          | Layer |        | Total  |         |
| 1  | 12,000 lb         | 5,440 kg | 182 ft/min           | 55.5 m/min | 10.3 in        | 261.9 mm | 66 ft | 20.1 m | 66 ft  | 20.1 m  |
| 2  | 10,800 lb         | 4,900 kg | 198 ft/min           | 60.4 m/min | 11.3 in        | 286.8 mm | 72 ft | 22.0 m | 138 ft | 42.1 m  |
| 3  | 9,800 lb          | 4,450 kg | 205 ft/min           | 62.5 m/min | 12.3 in        | 311.6 mm | 79 ft | 23.9 m | 217 ft | 66.1 m  |
| 4  | 9,000 lb          | 4,080 kg | 214 ft/min           | 65.2 m/min | 13.2 in        | 336.4 mm | 85 ft | 25.8 m | 302 ft | 91.9 m  |
| 5  | 8,300 lb          | 3,760 kg | 228 ft/min           | 69.5 m/min | 14.2 in        | 361.2 mm | 91 ft | 27.7 m | 393 ft | 119.6 m |

### STANDARD ENGINE

| Cummins QSB173 (U.S. EPA Tier 3)  |                         |                  |                         |                   |                            |
|---|-------------------------|------------------|-------------------------|-------------------|----------------------------|
| Noise Emissions: Top 96.3 dBA (excludes noise from intake, exhaust, cooling system and driven components) |                         |                  |                         |                   |                            |
| Type  | 6 Cylinder Water Cooled | Weight (Wet)     | 1005 lb (457 kg)        | Aspiration        | Turbocharged & Aftercooled |
| Displacement  | 359 cu in (5.9 l)       | Oil Capacity     | 17.2 US quarts (16.3 l) | Air Filter        | Dry Type                   |
| Bore  | 4.02 in (102 mm)        | Rated Horsepower | 173 @ 2200 rpm          | Electrical System | 12 volt                    |
| Stroke  | 4.72 in (120 mm)        | Peak Torque      | 590 ft/lb @ 1500 rpm    | Alternator        | 100 amp                    |

### MACHINE WEIGHTS

| STANDARD CRANE WITH 3 SECTION 80 ft 0 in (24.38 m) BOOM, 1 PIECE COUNTERWEIGHT & 30 in (762 mm) TRACK SHOES | 59,980 lb | 27,210 kg |
|---|-----------|-----------|
| Crane Less Counterweight  | 48,480 lb | 21,990 kg |
| Counterweight   | 11,500 lb | 5,220 kg  |
| OPTIONAL EQUIPMENT  |           |           |
| 20 ft (6.10 m) Lattice Extension  | 1,200 lb  | 544 kg    |
| 20 ft (6.10 m) Jib (connects to head of Lattice Extension ONLY)   | 700 lb    | 318 kg    |
| Auxiliary Nose Sheave   | 150 lb    | 68 kg     |
| Auxiliary Winch with Standard Rope  | 607 lb    | 275 kg    |
| 12 ton (11 mt) Headache Ball  | 180 lb    | 82 kg     |
| 30 ton (27 mt) Hook Block   | 760 lb    | 345 kg    |
| Auger Ready Package   | 440 lb    | 200 kg    |
| Complete Auger Package  | 1,520 lb  | 690 kg    |
| 60 in (1.52 m) Auger Kelly Bar  | 120 lb    | 54 kg     |
| 72 in (1.83 m) Auger Kelly Bar  | 140 lb    | 64 kg     |
| 72 in (1.83 m) Auger Kelly bar  | 140 lb    | 64 kg     |

\* Deduction from Standard Crane Weight



# SPECIFICATIONS

## MANTIS® 6010 30 TON TELE-BOOM CRAWLER CRANE

### UNDERCARRIAGE

#### Carbody

The steel box type carbody is fabricated with square axles to accept the crawler side frames. The top surface is precision machined to receive the swing bearing.

#### Side Frames

Two welded steel side frames are paired with a track group consisting of nine sealed rollers located on the bottom of the frame. Each frame includes a self-lubricating idler and spring type track tensioning device. Standard track shoes are 30 in (762 mm) wide, 3-bar semi-grousers. Optional shoes are available in 18 in (457 mm) and 24 in (609 mm) widths in both flat pad and semi-grouser configurations. Flat pads are also available in 30 in widths. The side frames extend and retract hydraulically and are controlled from the cab.

#### Travel

Each side frame contains a pilot controlled, two-speed track drive. The drives are hydraulic piston motors which propel the crane at a low speed of 2.0 mph (3.2 km/hr) and at a high speed of 3.0 mph (4.8 km/hr). The internal brake system is spring applied and automatically released upon actuation of the travel system.

The hydraulic travel system provides skid steering and track counter rotation and achieves an unladen gradeability of 56%.

### OPTIONAL EQUIPMENT

#### Boom Attachments

- **Boom Extension:** 20 ft (6.10 m), lattice type swingaway that stores alongside of the boom base section and can be used with or without the optional 20 ft (6.10 m) jib. Head contains two 19 in (483 mm) diameter high strength cast nylon sheaves mounted on heavy-duty roller bearings, reeving up to 2 parts of wire rope. With optional extension deployed maximum tip height is 102 ft (31.09 m).
- **Boom Jib:** 20 ft (6.10 m) lattice type swingaway, attaches to and stores alongside the extension and can only be used with the extension deployed. Offsets are at 15° & 30°. With jib and extension deployed maximum tip height is 124 ft (37.80 m).
- **Auxiliary Nose Sheave:** quick reeve, single 15 in (381 mm) diameter high-strength, cast nylon sheave mounted on a heavy-duty roller bearing.
- **Wire Rope:** rotation resistant, (non-spin) Dyform-18 HSLR.
- **Headache Ball:** 7 ton (11 mt) ball includes a swivel hook with a safety latch.
- **Hook Block:** 37 ton (27 mt) hook block contains three 16 in (406 mm) diameter sheaves mounted on heavy-duty roller bearings with a swivel hook and safety latch.

#### Hydraulic

- **Auger Ready Package:** includes hoses, fasteners and stowage bracket assembly mounted to the base section of the boom with a flow capability of 34 gpm (130 l/min).
- **Complete Auger Package:** adds a two speed auger motor/gear box and one 60 in (1.52 m) kelly bar to the Auger Ready Package.
- **Tool Circuit:** provides 6 gpm (23 l/min) and 12 gpm (45 l/min) at 2,500 psi (176 kg/cm<sup>2</sup>) through a 50 ft (15.24 m) twin hose reel with quick disconnect fittings to operate open center tools.

#### Other Options

- **Free Fall Hoists:** all winches are available in free fall and controlled free fall configurations.
- **Crane Cab Access Walkway:** a pair of 54.5 in (1.38 m) wide x 25 in (635 mm) deep walkways which attach to both the front and rear of the carbody and allow for easier egress and ingress to the operator's cab when the crane's upper rotating frame is not aligned front to rear.
- **Model WP750 Work Platform:** 36 in x 72 in (914 mm x 1 828 mm), all-steel, two-person platform with a maximum capacity of 750 lb (340 kg). A test weight and boom head adapter are included in the package. Operation and control are by the crane operator from the cab. Radio (RF) controls to enable remote operation from the platform are available.

*(See separate WP750 Specification for a complete description of standard and optional Work Platform equipment.)*