

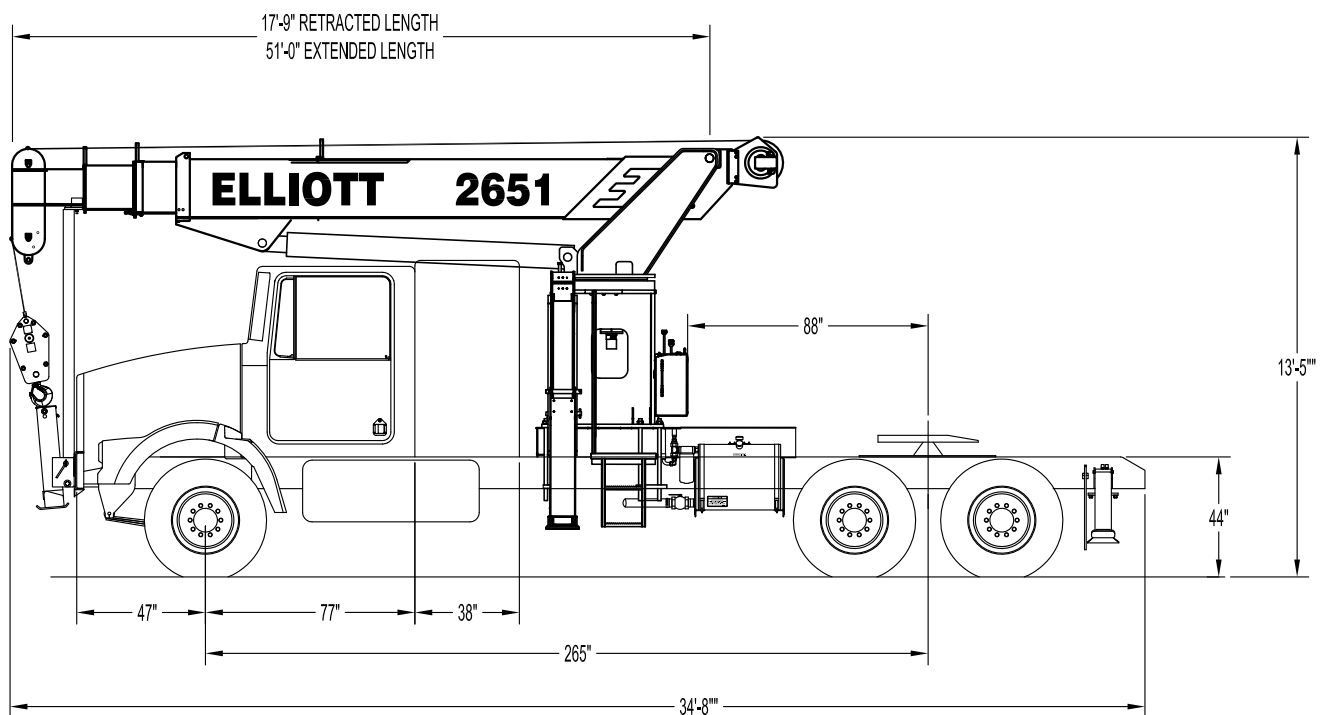

### 2651F SIDE VIEW DIAGRAM



- |                                  |                        |                                  |                               |
|----------------------------------|------------------------|----------------------------------|-------------------------------|
| • <b>Maximum Vertical Reach</b>  | 61' / 18,6 m           | • <b>Powered Boom Sections</b>   | 4                             |
| • <b>Working Area</b>            | 360 Degrees            | • <b>Overall Height (42" FH)</b> | 13'5" / 4 m                   |
| • <b>Lifting Capacity</b>        | 52,000 lbs / 23 587 kg | • <b>Operator Controls</b>       | Dual Operator Standup Console |
| • <b>Boom Length</b>             | 51' / 15,5 m           | • <b>Outrigger Type Front</b>    | "A" Frame                     |
| • <b>Crane Weight (Standard)</b> | 22,000 lbs / 9979 kg   | • <b>Outrigger Spread Front</b>  | 20'8" / 6,3 m                 |
| • <b>Jib Lengths</b>             | N/A                    | • <b>Outrigger Type Rear</b>     | Out-Down                      |
| • <b>Winch Bare Drum Pull</b>    | 12,800 lbs / 5806 kg   | • <b>Outrigger Spread Rear</b>   | 18'2" / 5,5 m                 |

## TECHNICAL SPECIFICATIONS

**Crane Capacity:** 52,000 lbs at 5' load radius.

**Maximum Tip Height:** 61' height.

**Control Console:** Dual standup operator control stations with Dynasmooth controls, pressure gauge, LMI display, bubble level gauge, engine start/stop switch, signal horn button, variable speed foot throttle, lifting capacity chart, range diagram chart, boom angle indicator, system pressure gauge, 12V DC power source, and cup holder. Outrigger lever controls at control consoles.

**Boom:** Four-section fully proportional, high strength steel plated rectangular tube sections. A maximum boom tip height of 61'. The boom nose contains one floating upper sheave and three lower sheaves. Assembly includes heavy-duty cylinder fittings, pivot pins, and replaceable wear pads.

**Winch:** Mounted at the base of the boom for a long fleet angle and flat level spooling of cable. Winch is driven by a planetary reducer and powered by a hydraulic motor. Burst-of-speed winch provides increased line speed. The winch brake is spring applied, pressure release design. Supplied with 425' of 9/16" diameter rotation resistant wire rope with a single line pull of 9,060 pounds, and a downhaul ball with swivel hook for single part line.

**Load Moment Indicator System:**

System senses hoist cylinder pressures, boom length and boom angle with hydraulic function lockout. The display console is equipped with a bar graph showing crane utilization, boom angle or boom length, a mode select controls for main boom and jib operation, and an anti-two block with an audio/visual warning and shut-off functions to limit hook-boom point contact.

**Outriggers:** One set of 'A' Frame front outriggers with 20'10" span and one set of out and down underslung rear

outriggers with 18'2" span. Outriggers are configured for full span operation.

**Frame:** 4-plate design sub-frame inside track tub. Sub-frame allows for bolt-on addition of steel diamond plated bed with stake pockets.

**Turret:** Reverse offset turret is one-piece weldment. Turret rotates on large diameter ball bearing.

**Rotation:** Hydraulic motor drives turret through double reduction planetary swing drive for 372 degree non-continuous rotation. The swing drive system has a spring applied, pressure release brake.

**Lift:** One double-acting long stroke cylinder provides smooth and stable boom elevation. Holding valve prevent boom from falling in event of hose failure.

**Boom Extension:** Incorporates a 2-stage hydraulic extension cylinder, attached to the largest boom section, with a proportional cable extension system driving the outermost sections.

**Hoses:** All high pressure hoses are wire braid reinforced with a minimum safety factor of 4 to 1.

**Cylinders:** All cylinders use microhoned cylinder tubing, chrome shafts, top grade packing and protective rod wipers. Cylinder-mounted holding valves provided on all load-holding cylinders.

**Hydraulic System:** Equipped with three-section gear pump, SAE O-ring face seals on pressure lines, and a 10-micron return line filter. The control valve distributes all flow to hoist system, swing circuit, and other crane functions. System is open center type.

**Oil Tank Capacity:** 120 gallon mounted on side of truck frame.

**Cab Equipment:** U/L approved 5:BC dry chemical fire extinguisher installed in truck cab.

**Operators Manual & Video:** Two CD copies and one hard copy of operation, maintenance, safety and parts manual provided with each unit. Operational and safety video provided at delivery.

**Installation:** Unit installed on truck chassis, painted, system and tank filled with oil, tested, inspected, and ready to operate.

**Standard Paint:** Paint turret and boom white, outriggers red, and bed and boxes black.

**Weight:** Approximately 22,000 lbs. (crane only).

**Chassis Required:** 60,000 lb GVWR capacity, 12V electrical system with high capacity alternator. Contact factory for complete specification review.

**Options:**

Continuous Rotation.

Shortjacking With Superlink Outriggers.  
18' Steel or Wood Bed.

Two-Person Gravity Leveled Work Platform.

Custom Toolboxes.

Hydraulic Tool Circuits on Bed.

Removable Boom Rest.

Front Recovery Winch.

Much more...

Elliott Equipment Company reserves the right to change the specification of any unit at any time without prior notice. This brochure is only a statement of general specifications on the date of this publication. For more detailed info on specific Elliott trucks go to [www.elliottequip.com](http://www.elliottequip.com)

**LOAD CHART - MAIN BOOM, FULL-SPAN OUTRIGGERS**

**MAIN BOOM LOAD RATINGS**





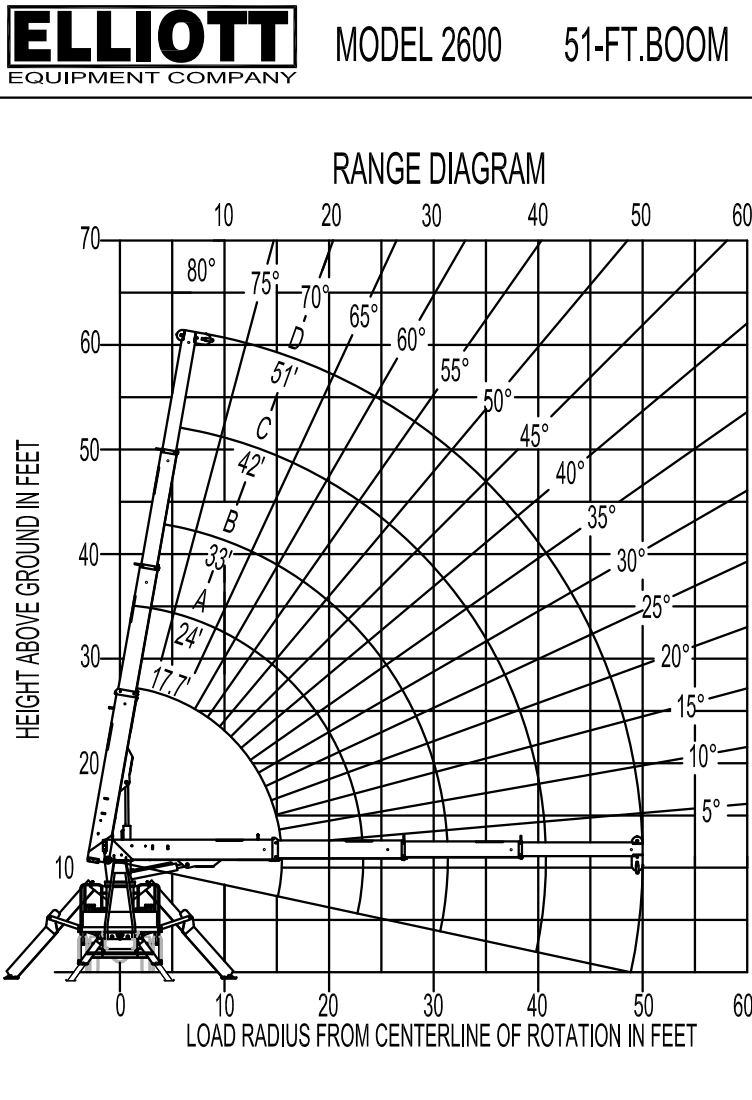

LOAD RATINGS IN LBS. WITH OUTRIGGERS AND STABILIZERS EXTENDED

LOAD RADIUS IN FEET	LOADED BOOM ANGLE	17.7-ft	LOADED BOOM ANGLE	A 24-ft	LOADED BOOM ANGLE	B 33-ft	LOADED BOOM ANGLE	C 42-ft	LOADED BOOM ANGLE	D 51-ft
5	70.9	52,000								
8	59.6	35,000	68.6	31,000						
10	51.4	30,300	63.2	27,200	71.2	24,000	75.6	23,000	78.3	21,000
12	42	26,000	57.5	23,300	67.4	21,000	72.7	20,000	75.9	18,900
14	30.2	22,100	51.3	21,000	63.5	18,700	69.7	17,600	73.5	16,200
16			44.5	18,800	59.4	17,000	66.7	15,700	71.1	14,800
18			36.9	17,000	55.1	15,500	63.6	14,000	69.2	13,000
20			27.4	15,000	51.6	15,500	61.2	13,000	66.7	12,650
25					38.9	11,000	52.8	10,600	60.2	10,300
30					20.3	8,600	43.3	8,700	53.3	8,600
35							31.6	7,000	45.8	7,300
40							12.2	5,000	37	6,100
45									25.8	4,600
	0	10,000	0	6,150	0	3,800	0	3,500	0	2,800

**RANGE CHART - MAIN BOOM, FULL-SPAN OUTRIGGERS**



**ALLOWABLE LINE PULL**

1-PART LINE	2-PART LINE	3-PART LINE	4-PART LINE	5-PART LINE	6-PART LINE	NOTICE
						<ul style="list-style-type: none"> <li>- DO NOT DEADHEAD LINE BLOCK AGAINST BOOM TIP WHEN EXTENDING BOOM.</li> <li>- KEEP AT LEAST 3 WRAPS OF LOADLINE ON THE WINCH DRUM AT ALL TIMES.</li> <li>- USE ONLY 9/16" DIAMETER WIRE ROPE, AS SPECIFIED BELOW, WITH THE PROPER BREAKING STRENGTHS LISTED.</li> <li>- ANTI-TWO-BLOCK SYSTEM MUST BE IN GOOD OPERATING CONDITION BEFORE OPERATING CRANE. SEE OPERATOR'S SAFETY MANUAL.</li> <li>- MAXIMUM CAPACITY WITH "BURST OF SPEED" IS 500 LBS.</li> </ul>
MAX PULL: 9,600 lbs	19,200 lbs	28,800 lbs	38,400 lbs	48,000 lbs	52,000 lbs	9/16" -6 x 37 1WRC (3.5:1 S.F.) 33,600-lbs BREAKING STRENGTH
MAX PULL: 9,060 lbs	18,120 lbs	27,180 lbs	36,240 lbs	45,300 lbs	52,000 lbs	9/16" -SPIN RESISTANT (5:1 S.F.) 45,300-lbs BREAKING STRENGTH

DEDUCTIONS FROM RATED LOADS FOR HANDLING DEVICES SUPPLIED BY ELLIOTT EQUIPMENT CO,  
 OVERHAUL BALL -----SEE OVERHAUL BALL MFGR. NAMEPLATE  
 LOAD BLOCK -----SEE BLOCK MFGR. NAMEPLATE  
 SWING AROUND JIB -----SEE LOAD RATING CHART

**CHASSIS SPECIFICATIONS**

	2651F BoomTruck
Wheelbase (WB)	256" / 650 cm
Cab to Tandem (CT)	192" / 488 cm
Cab to End of Frame (EOF)	390" / 792 cm
Frame Section Modulus	15.9 in3-110,000 psi / 758,428 kPa
Front Axle Gross Weight Rating	20,000 lb / 9071 kg
Rear Axle Gross Weight Rating	40,000 lb / 18 143 kg
Integral Front Frame Rails	Required for Front Stabilizer

Chassis data is minimum general requirements-not for engineering.  
 Actual dimensions and truck data will depend on truck selection and axle configuration.  
 \*Minimum chassis weight is required to meet 85% stability requirements.

**OPTIONS**



**Radio Remote Control**

Interference protected radio remotes let you get closer to your work and have full control over your machine. Includes battery charging feature and optional LMI screen.



**Superlink Short Jack Outriggers**

Reduce your outrigger spread with Elliott's patented Superlink outriggers that allow straight down outrigger deployment on one side and unrestricted lifting on the other.



**Continuous Boom Rotation**

Add the convenience of 360 degree area of operation by adding a front stabilizer and continuous rotation mechanism.



**Hydraulic Oil Cooler**

Add a bed-mounted hydraulic oil cooler to assist with high duty cycle job applications.



**Tool Boxes**

Optional tool boxes and bed storage can accommodate any storage need for tools, work materials and more.

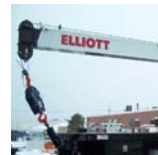

**Hook Block for Multi-Part Line**

Elliott can install a 2-3 part hook block or a 4 part-hook block to improve lifting capabilities. The block can be stored at the rear of the bed.



**Gravity Leveled Basket**

Elliott's pin-on work platform pins onto the boom for easy installation and removal. Gravity leveling and mechanical rotation makes it a great accessory for any worksite.



**Body Mounted Hose Reels and Circuits**

Let us work with you to customize your tool compatability by adding hose reels or hydraulic circuits to the crane bed.