



# TEREX®

## COMMANDER 6000 SERIES

### DIGGER DERRICK

Terex® Telelect Digger Derricks are known throughout the industry. They come with a long history featuring quality and innovative design.

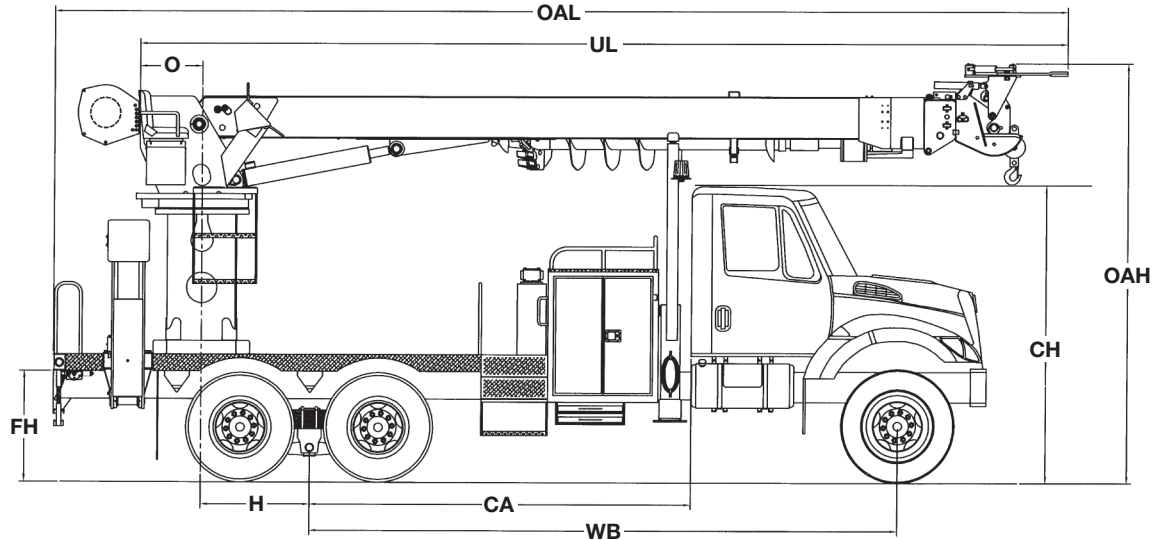

Measurements	Commander 6051	Commander 6054	Commander 6060
	ORA	ORA	ORA
Typical Frame Height (FH)	40 in. (101.6 cm)	40 in. (101.6 cm)	40 in. (101.6 cm)
Typical Cab Height (CH)	112 in. (284.5 cm)	112 in. (284.5 cm)	112 in. (284.5 cm)
Offset (O)	44.62 in. (113.3 cm)	44.62 in. (113.3 cm)	44.62 in. (113.3 cm)
Overall Height (OAH)	12' 8" (3.9 m)	12' 8" (3.9 m)	12' 8" (3.9 m)
Overall Length (OAL)	27' 2" (8.3 m)	28' 2" (8.6 m)	30' 2" (9.2 m)
Unit Length (UL)	26' 11" (8.2 m)	27' 11" (8.5 m)	29' 11" (9.1 m)
Center of Rotation (H)	39.5 in. (100.3 cm)	39.5 in. (100.3 cm)	39.5 in. (100.3 cm)
Cab to Axle (CA)	138 in. (350.5 cm)	138 in. (350.5 cm)	138 in. (350.5 cm)
Wheel Base (WB)	210 in. (533 cm)	210 in. (533 cm)	210 in. (533 cm)
Front Axle (GAWR)	12,000 lb. (5,443 kg)	12,000 lb. (5,443 kg)	12,000 lb. (5,443 kg)
Rear Axle (GAWR)	34,000 lb. (15,422 kg)	34,000 lb. (15,422 kg)	34,000 lb. (15,422 kg)
Gross Vehicle Weight Rating (GVWR)	46,000 lb. (20,865 kg)	46,000 lb. (20,865 kg)	46,000 lb. (20,865 kg)
Recommended Weight for Stability	35,000 lb. (15,876 kg)	35,000 lb. (15,876 kg)	35,000 lb. (15,876 kg)
Frame Section Modulus	18.0 in <sup>3</sup>	18.0 in <sup>3</sup>	18.0 in <sup>3</sup>
Frame Yield Strength	50,000 psi	50,000 psi	50,000 psi
Frame RBM	900,000 in-lbs	900,000 in-lbs	900,000 in-lbs



# TEREX®

500 Oakwood Drive  
PO BOX 1150  
Watertown, SD 57201-6150  
USA

Phone: (605) 882-4000  
Facsimile: (605) 882-1842  
www.terexutilities.com  
E-mail: utilities.info@terex.com

**Distributed By:**

# COMMANDER 6000 SERIES

## STANDARD EQUIPMENT

- 100 Degrees of Boom Travel (+80 to -20)
- Dual Lift Cylinders
- Self-Aligning Swivel Ball Bushings
- Rectangular, Bi-Axial Epoxy Resin, Filament Wound Fiberglass Booms
- Box Fabricated Steel Lower Boom and Intermediate
- Hydraulic Boom Extension Intermediate & Upper
- Full Pressure Hydraulic Controls
- Full Pressure, Open-Center Hydraulic System
- 50 Gallon Hydraulic Oil Reservoir
- Custom Made Zoned Load Chart
- Continuous Unrestricted Rotation
- 15,000 lb. Planetary Turntable Winch
- Meets or Exceeds ANSI A10.31
- Transferable Pole Flanges
- Planetary Parking Brake Rotation
- Right-Hand Command Post Controls
- Engine Stop/Start at Lower Controls
- Boom Angle Indicator
- Boom Interlock
- Moving Outrigger Alarm
- Truck Level Indicator

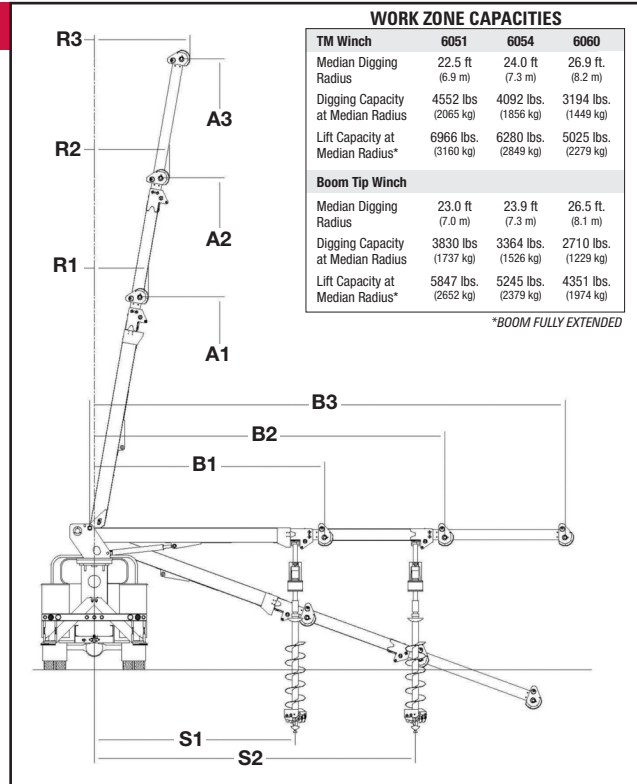

## CAPACITIES & DIMENSIONAL DATA (Based on a 40 Inch Frame Height)

Model	Maximum Capacity	Capacity @ 10 ft Radius	Sheave Height			Load Radius			Horizontal Reach			Digging Radius	
			A1	A2	A3	R1	R2	R3	B1	B2	B3	S1	S2
<b>CMDR 6051</b>	36,000 lb (16,330 kg)	19,100 lb (8,664 kg)	31.4 ft (9.6 m)	41.3 ft (12.6 m)	51.1 ft (15.6 m)	3.5 ft (1.1 m)	5.2 ft (1.6 m)	7.1 ft (2.2 m)	21.3 ft (6.5 m)	31.3 ft (9.5 m)	41.3 ft (12.6 m)	18.3 ft (5.6 m)	28.3 ft (8.6 m)
<b>CMDR 6054</b>	36,000 lb (16,330 kg)	18,500 lb (8,391 kg)	32.4 ft (9.9 m)	43.2 ft (13.2 m)	54.1 ft (16.5 m)	3.7 ft (1.1 m)	5.6 ft (1.7 m)	7.6 ft (2.3 m)	22.3 ft (8.8 m)	33.3 ft (10.1 m)	44.3 ft (13.5 m)	19.3 ft (5.9 m)	30.3 ft (9.3 m)
<b>CMDR 6060</b>	36,000 lb (16,330 kg)	18,100 lb (8,210 kg)	34.4 ft (10.5 m)	47.2 ft (14.4 m)	60.0 ft (18.3 m)	4.0 ft (1.2 m)	6.3 ft (1.9 m)	8.6 ft (2.6 m)	24.3 ft (7.4 m)	37.3 ft (11.4 m)	50.3 ft (15.3 m)	21.3 ft (6.5 m)	34.3 ft (10.5 m)

## OPTIONAL EQUIPMENT

- Various Digger/Augers
  - Auger Storage Left Side (Typical)
  - Auger Storage Right Side (Subject to Configuration)
- Fiberglass Personnel Platform
  - Liners With or Without Steps
- Handle Rack Controls
- Various Types of Controls
- Radio Remote Controls
- Full Pressure Upper Controls
- Single Stick "T" Controls
- Engine Stop/Start and Throttle Advance at Top Controls
- Various Types of Advance Throttle at Lower Controls
- Hydraulic Overload Protection (HOP)
- Boom Tip Winch
- Material Handling Jibs
- Transferable Pole Flanges
- Various Sizes of Pole Guides
- Pole Guide Interlock
- Planetary Slip Brake Rotation
- Hydraulic Tool Outlets
- Pole Puller
- Multi-Part Line Components
- Boom Storage Warning Light
- Outrigger Sag Light
- Various Types of Outriggers
- Truck Grounding Cable & Clamp

Effective Date: February 2014. Product specifications and prices are subject to change without notice or obligation. The photographs and/or drawings in this document are for illustrative purposes only. Refer to the appropriate Operator's Manual for instructions on the proper use of this equipment. Failure to follow the appropriate Operator's Manual when using our equipment or to otherwise act irresponsibly may result in serious injury or death. The only warranty applicable to our equipment is the standard written warranty applicable to the particular product and sale and Terex makes no other warranty, express or implied. Products and services listed may be trademarks, service marks or trade-names of Terex Corporation and/or its subsidiaries in the USA and other countries. All rights are reserved. Terex® is a registered trademark of Terex Corporation in the USA and many other countries. Copyright 2014 Terex Corporation.