

Mobile Crane LTM 11200-9.1

Max. Capacity: 1,200 t
Max. Hoisting height: 188 m
Max. Radius: 136 m



LIEBHERR

Mobile Crane LTM 11200-9.1 **With maximum capacity** **universally useable**



The LTM 11200-9.1 with its capacity of 1,200 t is the strongest telescopic mobile crane in the market and offers the worldwide longest telescopic boom. A remarkable increase of the capacity is realized with the Y-telescopic boom suspension. Short erection times, an extraordinary mobility as well as a comprehensive comfort and safety configuration distinguish the mobile crane LTM 11200-9.1 from Liebherr.

- **100 m long telescopic boom and 22 m telescopic boom extension (10 m + 6 m + 6 m)**
- **Capacity 65 t at the 100 m long, suspended telescopic boom**
- **126 m long luffing fly jib**
- **60.5 m long fixed jib, optionally hydraulically adjustable**
- **Fast and comfortable erection with marginal required space**
- **Optimal for assemblies in the industry, in the wind power generation field and at infrastructure projects**
- **Active, speed depending rear axle steering, all axles steered**
- **Economical transportation**



Large operation spectrum with high performance and variable boom systems

Erection of a portal crane

Load 129.5 t each crane at
max. 21 m radius

Crane 1:
System T3Y
Telescopic boom 55 m + Y-suspension

Crane 2:
System T7Y
Telescopic boom 53.3 m +
Y-suspension





Erection of a radio tower

Load 9.5 t to 154 m hoisting height at
31 m radius

System T3YV2VEN
Telescopic boom 52.2 m + Y-suspension +
adapter 20.2 m + luffing fly jib 90 m



Erection of an absorber column

Load 128 t at max. 21 m radius

System T7Y

Telescopic boom 65 m + Y-suspension

Outstanding capacities at large radii with luffing fly jib





Optimized for the installation of wind power generators

100 m-telescopic boom + Y-guying system

Height of hub of wind power generator	Max. capacity at radius	Hook height	System
80 m	84 t x 16 m	92 m	T7Y

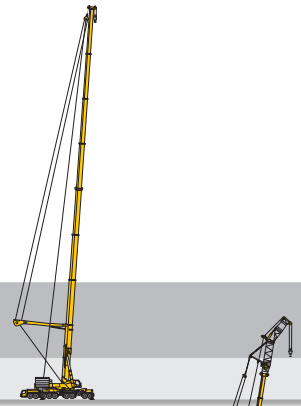

100 m-telescopic boom + Y-guying system + fixed jib

Height of hub of wind power generator	Max. capacity at radius	Hook height	System
80 m	94 t x 20 m	89 m	T7YVENZF
100 m	76 t x 16 m	107 m	T7YVEV2NZF
105 m	65 t x 16 m	114 m	T7YVEV3V2NZF

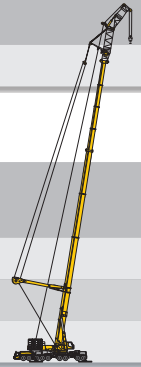

52 m-telescopic boom + Y-guying system + luffing jib

Height of hub of wind power generator	Max. capacity at radius	Hook height	System
80 m	141 t x 18 m	90 m	T3YVEN
100 m	97 t x 22 m	112 m	T3YV2VEN
105 m	83 t x 24 m	117 m	T3YV2VEN
120 m	58 t x 32 m	128 m	T3YV2VEN
130 m	38 t x 36 m	138 m	T3YV2VEN
140 m	26.1 t x 44 m	148 m	T3YV2VEN
150 m	15.8 t x 50 m	158 m	T3YV2VEN

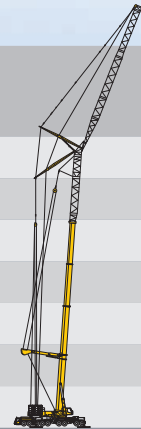



Economical transportation

The chassis drives on the road with slewing platform, luffing cylinder and all four folding beams.

The chassis weight and the axle loads can further be reduced by dismantling of equipment components.

	Axle 1-2	Axle 3-9	Total weight
Vehicle without telescopic boom	12 t	12 t	108 t
Vehicle without telescopic boom, without winches	< 10 t	< 12 t	< 100 t
Vehicle without telescopic boom, without winches, without swing-out beams	< 9 t	< 9 t	< 76 t

The boom is transported separately on a low bed trailer. For this different variations are possible.

Variable boom transportation concept (examples)



Heel section + telescope 1



52 m telescopic boom



52 m telescopic boom + Y-suspension



100 m telescopic boom



100 m telescopic boom + Y-suspension
Stated weights without boom lifting unit





Flexible driving on the job site

The LTM 11200-9.1 can drive on the job site with the better part of its equipment on board.

- Reduction of mobilisation times
- Driving inside of a width of 3 m
- Safe driving due to a low centre of gravity
- Boom assembly outside of the job site at limited site space



Simple and speedy boom assembly





The assembly of the boom on the job site can optionally be carried out without an auxiliary crane. By means of four special support jacks the boom is lifted so that the low bed trailer can move off and the chassis of the LTM 11200-9.1 can be positioned below the boom to the front or the rear. The boom can now be mounted to the chassis with a few manual actions.

Economical crane assignment logistic

A multitude of heavy duty crane operations can be performed with a small number of transportation vehicles. For the erection of a wind power plant with a hub height of 80 m and a component weight of up to 80 t for example only four transportation units are necessary:

Crane LTM 11200-9.1 – self propelled

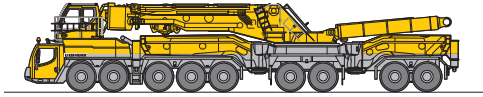

Transport of telescopic boom T7 – 100 m

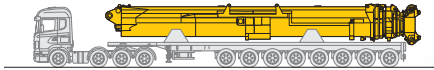

Transport of the Y-suspension plus 30 t ballast

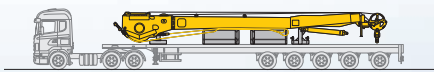

Transport of 52 t ballast incl. base plate



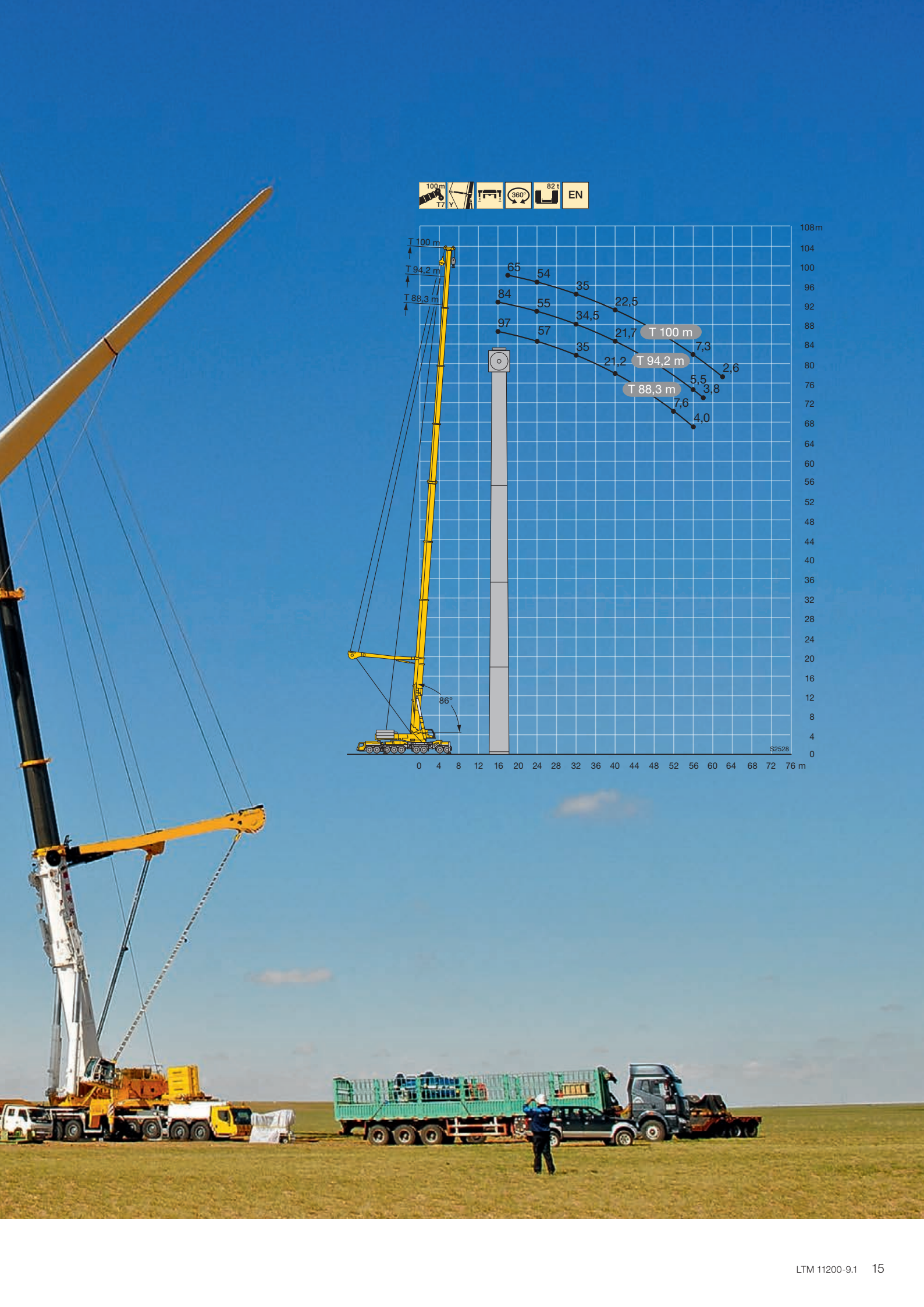







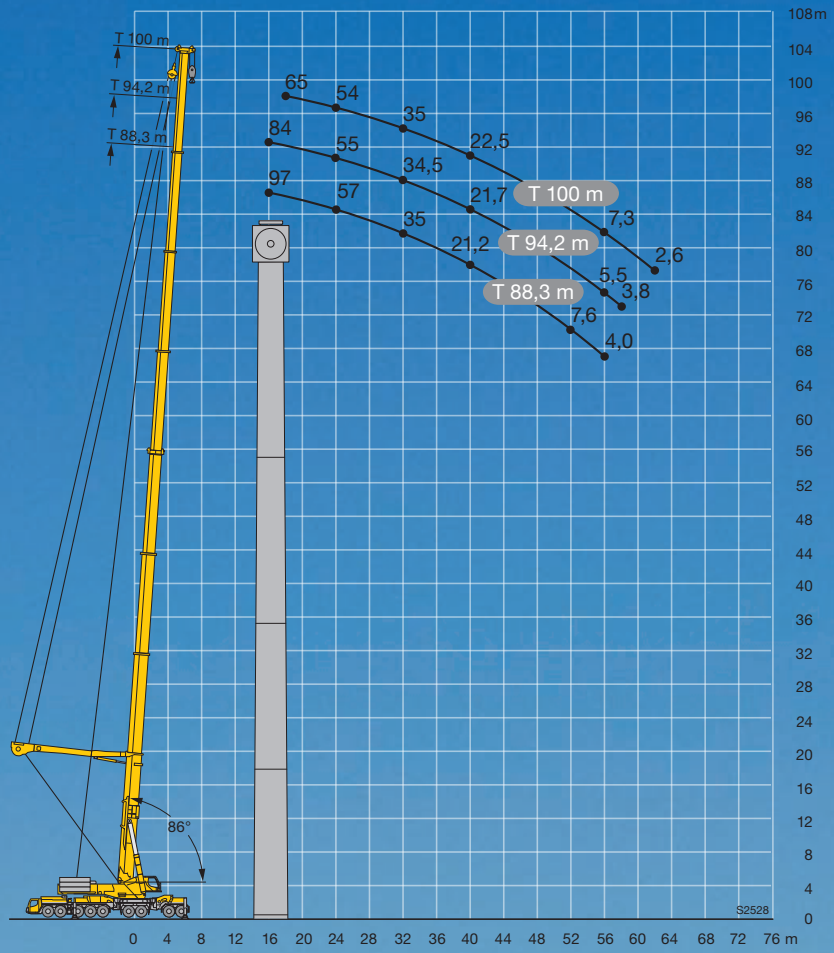

Counterweight

The ballast concept of the LTM 11200-9.1 developed by Liebherr offers numerous advantages for the crane operator.

- Dimensions and weights of the ballast plates are ideally adapted to the low bed trailers
- Complete ballast assembly without an auxiliary crane
- High economy due to compatibility of the ballast weights with those of other large Liebherr cranes
- Comfortable and safe ballasting with the mobile control and display unit BTT



Base plate	22 t
16 identical plates 10 t each	160 t
4 identical plates 5 t each	20 t
Total ballast	202 t

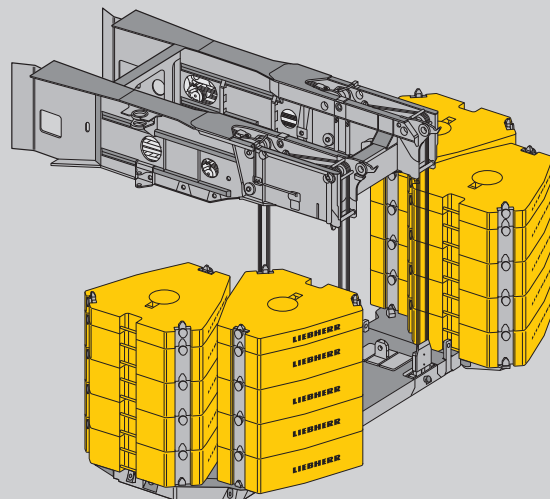

The large scale ballast distribution with two ballast stacks on each side provides by the low working height for improved safety and ergonomic working conditions.



Simple pinning of the base plate to the ballasting device

Self assembly of hoist gear 2

Chassis and drive technology



Hydro pneumatic axle suspension „Niveaumatik“

- Maintenance-free suspension cylinders
- Large dimensions to cope with high axle loads
- Spring travel +175/-125 mm
- High side stability at cornering
- Choice of the driving conditions by fixed programmes



Air operated disk brakes

- Higher braking power, better brake control
- Improved track stability
- No brake fading at higher operation temperatures
- Higher service life
- Shorter working times for changing of the brake pads
- Brake pads with wear indication

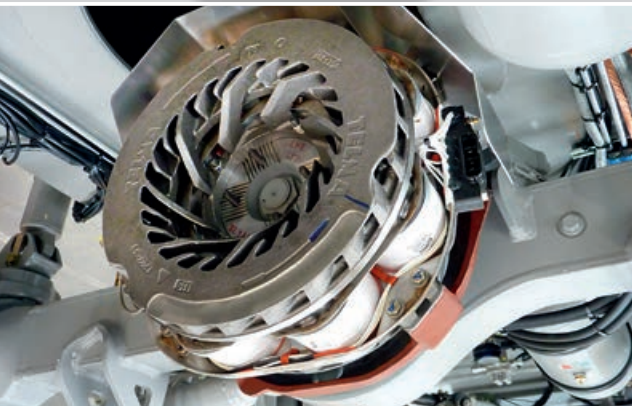

Intarder and Telma-Eddy current brake as standard

- No wear, low maintenance system
- Increased safety due to fast activation in milliseconds
- Reduction of operation costs
- High comfort due to braking absolutely without jolts
- Environmentally friendly brake system, no emission and respirable dust

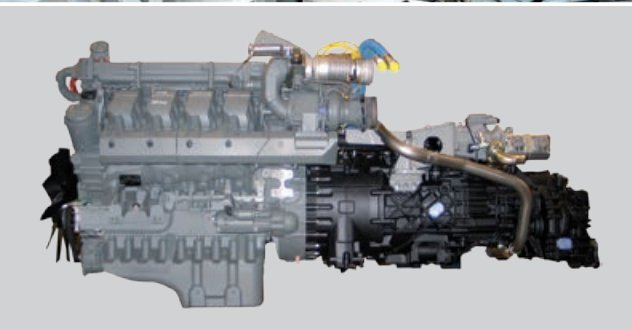

Chassis engine

- Powerful 8-cylinder turbo diesel engine with 500 kW/680 HP, max. torque 3,000 Nm
- Automated 12-speed-shift system ZF-TC-TRONIC with torque converter and intarder directly at the gearbox offers high efficiency and best comfort
- Axle 1, 2, 4 and 5 are driven axles



Superstructure engine

- 6-cylinder Liebherr turbo diesel engine, 270 kW/367 HP, max. torque 1,720 Nm
- Optimized fuel consumption due to electronic engine management

Variable steering concept

Active rear axle steering

- Electro hydraulic steering of the rear axles depending on the speed and the steering angle of the front axle
- Distinct reduction of the tyre wear
- Improvement of the manoeuvrability
- Stable driving performance
- All 9 axles steerable, no lifting of the middle axles during crab steering



High safety standards

- Centralizing cylinders for automatic straightening of the rear axles in case of failure
- Two independent hydraulic circuits with wheel driven and motor driven hydraulic pumps
- Two independent steering computers

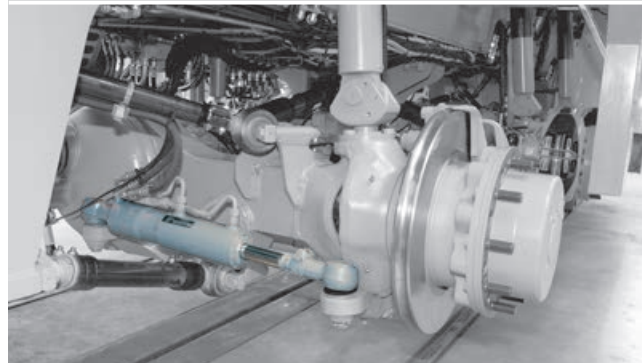

5 steering programmes

- Programme selection by simple push button
- Clear arrangement of the control elements and displays
- Programmes changeable during driving
- Crab steering controlled comfortably by the steering wheel



P1 Road steering



P2 All-wheel steering



P3 Crab steering

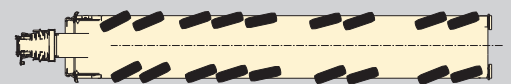

P4 Reduced swing out



P5 Independent rear axle steering



Comfort and functionality

The modern driving cab as well as the movable crane cab offer a comfortable and functional working place. The control elements and displays are arranged according to ergonomic factors. Thus a safe and wear free working is assured.

The driver's cab

- Corrosion resistant
- All around safety glazing
- Tinted windows
- Heatable and electrically adjustable outside mirrors
- Air cushioned driver's seat with lumbar support
- Engine independent additional heating, air condition

The crane cab

- Optimized heating and ventilation system, automatic temperature control, engine independent additional heating, air condition
- Extended field of view due to large screens
- Crane driver seat with lumbar support, multiply adjustable
- 20° tiltable to the rear
- Can hydraulically be lowered for a comfortable access



Crane supporting – fast, comfortable and safe

- BTT – Bluetooth Terminal, mobile control and display device
- Electronic inclination display
- Fully automatic leveling by push button
- Display of supporting forces
- Engine start/stop and speed regulation
- Lighting of the support area with 4 integrated floodlights
- Stroke of supporting cylinders 750 mm
- Folding beams slewable, 2-fold telescopic

Safe working with well-thought-out solutions

The supporting, the boom and counterweight assembly as well as the attachment of additional equipment are designed for speed, safety and comfort. For the safety of the operating personnel ascents, holding grips and railings are furnished.

For the observation of the winches and the Y-suspension in operation mode cameras are installed, which transfer their pictures to the crane cab. Likewise a back-up camera system for a safe and comfortable reversing is in place.



Intelligent crane control

For functional and safe crane operation, the LICCON computer system

The soft- and hardware of the mobile crane control is developed by Liebherr in-house. The centre is the LICCON computer system (Liebherr Computed Control).

- Integrated LML-load moment limiter
- Key components are in-house manufactured by Liebherr
- Guaranteed availability of spare parts
- Worldwide proven under the most different climate conditions
- Operator friendly

The data bus technology

Liebherr mobile cranes are completely interlaced by the data bus system. All important electric and electronic components are equipped with own micro processors and communicate with each other by only limited data cables. For the special demands of the mobile crane Liebherr has developed own data bus systems (LSB – Liebherr-System-Bus). The data bus technology improves the reliability, the comfort and the safety for road driving and crane operation:

- Higher reliability due to remarkable less electric cables and contacts
- Continuous self testing of the „intelligent sensors“
- Comprehensive diagnosis possibilities, fast fault finding



BTT-Bluetooth Terminal

For the remote control of crane assembly functions like e.g. supporting, boom assembly and the ballasting

- Free view and proximity to the assembly work
- Higher comfort and economy

The LICCON work planner

- Computer programme for planning, simulation and documentation of crane operations at the PC
- Display of all load charts belonging to a specific crane
- Automatic search for the suitable crane by input of the load case parameters load, radius and hoisting height
- Simulation of crane operations with drawing functions and display of support forces



LTM 11200-9.1



PN 178.00.E02.2014

The pictures contain also accessories and special equipment not included in the standard scope of delivery. Subject to modification

Liebherr-Werk Ehingen GmbH

Postfach 1361, 89582 Ehingen, Germany

☎ +49 7391 502-0, Fax +49 7391 502-3399

www.liebherr.com, E-Mail: info.lwe@liebherr.com

www.facebook.com/LiebherrConstruction