



Increased productivity:

- ➔ Electric drive with the ability to drive at full height
- ➔ Compact and easy to drive
- ➔ Smooth and accurate controls
- ➔ Lightweight machine

Specs at a glance:

- ➔ 16 working height
- ➔ Max width only 2 ft 8 in
- ➔ Drive speeds up to 3 mph

227 kg
500 lb / 2x  LR 10 SP

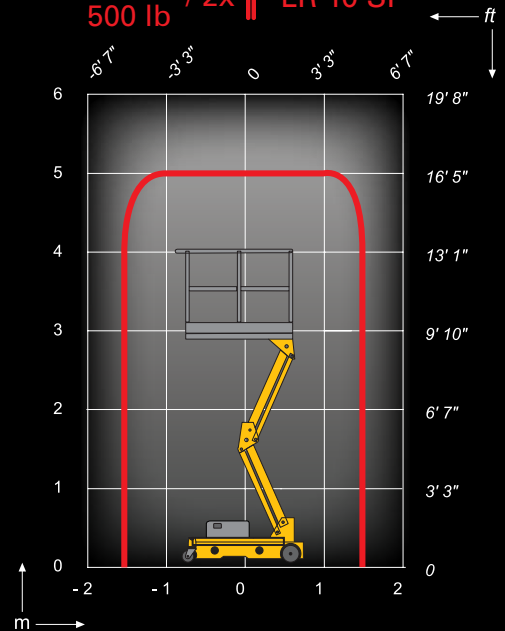

Haulotte 
GROUP

More Than Lifting



www.haulotte-usa.com

LiteRiser 10 SP

Vertical Masts

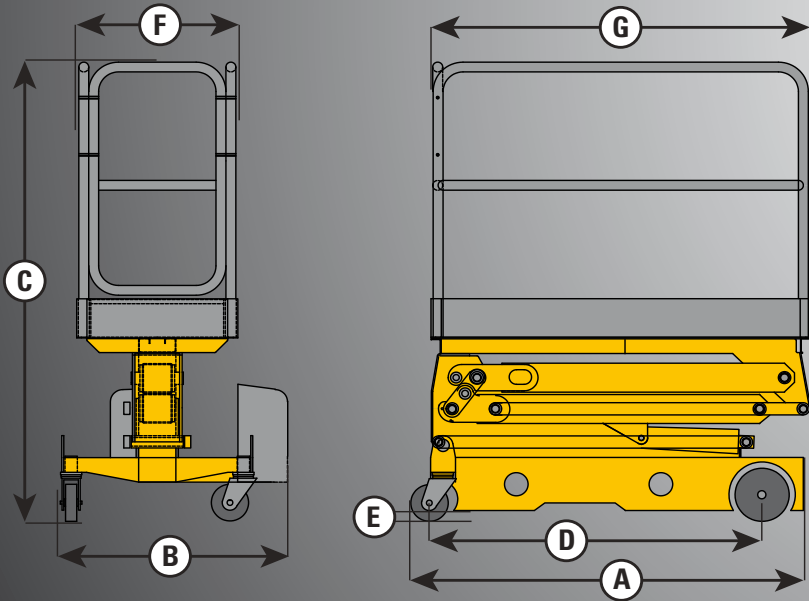

TECHNICAL SPECS

LR 10 SP

Working height	16 ft
Platform height	10 ft
Lift capacity	500 lb
A - Length	5 ft 9 in
B - Width	2 ft 8 in
C - Stowed height	6 ft 4 in
D - Wheelbase	4 ft
E - Ground clearance	1 in
F x G - Platform size	2 ft 3 in x 4 ft 9 in
Drive speed	0.6 - 3 mph
Outside turning radius	6 ft 3 in
Inside turning radius	0
Batteries	2 x Maintenance free 100 amp-hr
Gradeability	25%
Non-marking tires	Caster: 8 in x 2 in Drive: 13 in x 4 in
Brakes	Spring applied / Electric release
Weight	1,250 lb

STANDARD EQUIPMENT & HIGHLIGHTS

- Lightweight and compact
- 30 amp automatic battery charger
- 24 V electric drive
- Travels through a standard doorway
- Forklift pockets
- Zero inside turning radius
- Simple to use control system with adjustable parameters

OPTIONS & ACCESSORIES

- Alarm package



Haulotte 
GROUP