

**Winlet**  
**1320**



Pat. Pending

Visit our **NEW** web page!  
[www.winletusa.com](http://www.winletusa.com)

## ***Don't break your back - or the glass!***

- Lifts 1320 lbs
- Safer than manual handling
- Self propelled
- Improve job efficiency and work environment
- Access narrow doorways, elevators and balconies
- Twin wheels for rough terrain operations

**GOOD  
DESIGN**

2011 Winner

THE CHICAGO  
ATHENAEUM  
MUSEUM OF  
ARCHITECTURE  
AND DESIGN



### **Lift airtight materials:**

- **Glass**
- **Granite**
- **Concrete**
- **Plastic Sheets**
- **Steel Plates**
- **Wooden Sheets**
- **Tiles / Marble**
- **Fire Doors**
- **Aluminum Sheets**

## REACH DIAGRAM

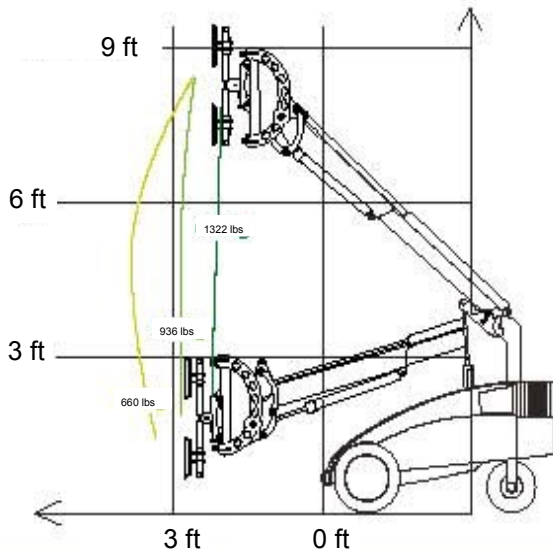

## PICKUP AND PLACE DIAGRAM

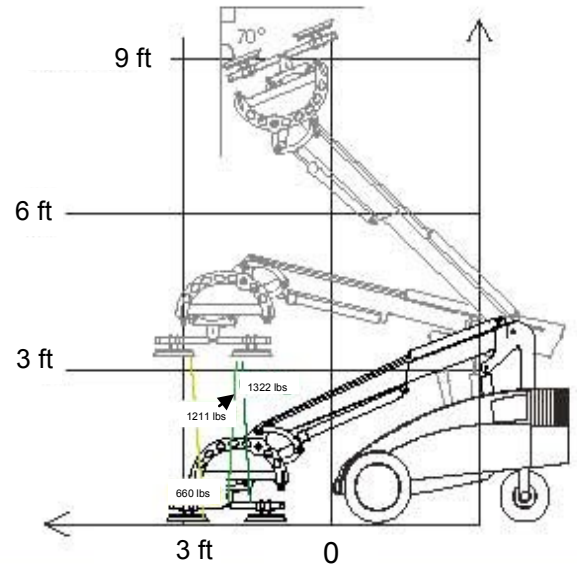

- **User friendly**
- **Easy to transport**
- **Increase efficiency**
- **Double action safety keys**
- **Improve safety on jobsites**
- **Gyro feature standard**
- **Increase your bottom line**
- **Multi functional control box**

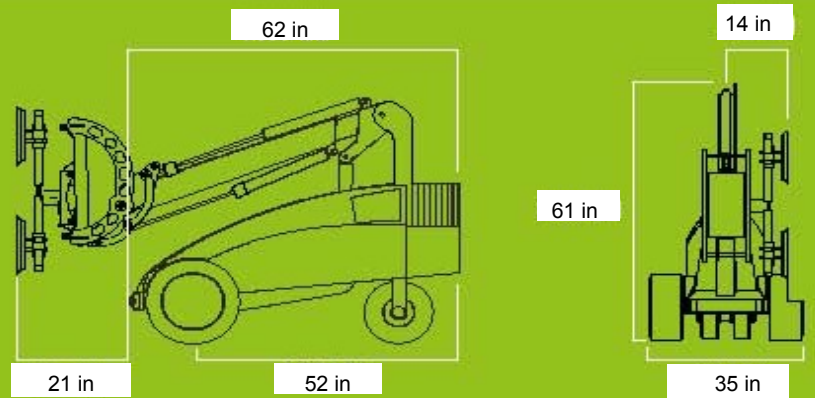

## Specifications

External Length	62 in
External Width	35 in
Max. Lifting Capacity	1322 lbs
Max Load at Max Extension	660 lbs
Max Load on Side	660 lbs
Total Weight –excl counterweight	1905 lbs
Total Weight - incl counterweight	2335 lbs
Min. Extension	23 in
<i>(Horizontal arm-front bumper to suction cup )</i>	
Max Extension	51 in
<i>(Horizontal arm-Front bumper to suction cup)</i>	
Max Lifting Height	110 in
<i>(to center of lifting yoke)</i>	
Side Offset	4 in
Fine Lift on Arm	8 in
Tilt Function	160°
Continuous Rotation	360°
Suction cups	4 x 15 in
Batteries	2 x 95 AH



### Accessories

- **Quick connector**
- **Twin wheels for rough terrain**
- **Support wheels – extra stability**
- **Lifting fork for pallets**
- **Lifting hook for straps**
- **Forklift Adapter**



### Superior Operator Interface

- **Operator friendly design**
- **Portable**
- **Easy to understand buttons and signal lights**
- **All functions in one place**
- **Double safety keys for material release**