

15010

77 Ton Tele-Boom Crawler Crane



 TADANO

MANTIS[®]
CRANES

mantiscranes.com



MANTIS[®] CRANES

VERSATILE. POWERFUL. DEPENDABLE.

Tadano Mantis cranes are engineered as VERSATILE, heavy-duty machines. We match massive steel fabrications with diesel engines and state of the art hydraulics to provide a POWERFUL crane that meets the toughest demands in full load pick-and-carry as well as lift applications. MANTIS... the one DEPENDABLE crane that does it all on your jobsite



OPTIONAL EQUIPMENT



AUGER AND POLE CLAW



WORK PLATFORM



LIGHT BAR AND TOOL CIRCUIT

FEATURES

NO OTHER CRANE COMBINES SO MANY VALUABLE FEATURES:

- Pick-and-carry the full crane load chart through 360°.
- Lift and walk...even with tracks retracted.
- Climb steeper grades, thanks to minimized counterweight and low center of gravity.
- Pull through deep mud without bogging down.
- Telescope or lift the boom with a full load on the hook.
- Save time and money on the job due to low clearance height, retract on-the-fly tracks and telescopic boom.
- Independent hydrostatic track drives allow pivot turns and counter rotation
- Hydraulic tool circuit option powers wide choice of Mantis-approved tools.



Standard operators cab tilts up for improved operator comfort. Improved design walkways allow easy access into the cab.



Spacious cab, adjustable seat, and conveniently located controls are common in all Tadano Mantis Cranes.



Cameras display the winch as well as the blind area directly behind the crane. Full color video display in operator cab is standard equipment.



Large access doors, spacious machinery compartments simplify preventative maintenance and service of the crane.



Tadano AML-C rated capacity indicator provides continuous feedback of crane lift position and data

SPECIFICATIONS

MAXIMUM LIFTING CAPACITY

77 ton at 10 feet (70t at 3.0m)

BOOM

4-section full power synchronized telescoping boom. Synchronized telescoping system consists of two double acting hydraulic cylinders with load holding valves and extension and retraction cables.

- Retracted Length: 37'6" (11.4m)
- Extended Length: 111'6" (34 m)
- Extension Time: 102 s
- Elevating Angles: -1° to 78°
- Elevating Time: 64 s
- Boom Head: Seven, 19 inch (483 mm) diameter cast nylon sheaves on heavy-duty roller bearings (5 load bearing and 2 lead in sheaves)
- Auxiliary Boom Head: Quick reeve, single 19 inch (483 mm) diameter high-strength, cast nylon sheave mounted on a heavy-duty roller bearing.
- Hook Block: 80 ton (72.5t) hook block - Five 19 inch (483 mm) diameter sheaves mounted on heavy duty roller bearings with swivel hook and safety latch.
- Headache Ball: 12 ton (11t) ball includes a swivel hook with a safety latch.

WINCHES

Planetary geared two-speed winch includes a bent axis hydraulic motor, multi-disc internal brake, counterbalance valve, grooved drum and cable follower. Drum rotation indicator is included

- Main Winch
 - Rope Diameter and Length: ¾" x 700 ft (19mm x 213m)
 - Single line pull: 17,590 lb (78.2 kN) (first layer)
 - Single line speed: 225 ft/min (68.6 m/min) (4th layer)
- Auxiliary Winch
 - Rope Diameter and Length: ¾" x 350 ft (19mm x 107m)
 - Single line pull: 17,590 lb (78.2 kN) (first layer)
 - Single line speed: 225 ft/min (68.6 m/min) (at the 4th layer)

TRAVEL

Each side frame contains a pilot controlled, two-speed track drive with hydraulic axial piston motor and parking brake. Travel system provides skid steering and counter rotation.

- Low travel speed: 0.6 mph (1.0 km/h)
- High travel speed: 1.7 mph (2.8 km/h)
- Gradeability (unladen): 68%

LOAD MOMENT INDICATOR & ANTI -TWO BLOCK

TADANO AML-C Rated Capacity Limiter and Anti-Two Block system

- Control function shutdown. Audible and visual warnings
- LCD screen provides a continuous display of working boom length, boom angle, working load radius, tip height, parts-of-line (operator set), machine track configuration (operator set), relative load moment, maximum permissible load and actual load.
- Optional 3-color light bar for external indication of load state.

OPERATOR'S CAB

Fully-enclosed, air conditioned all-steel modular cab with lockable swinging door, acoustical lining, anti-slip floor and tinted safety glass.

- Cab tilts 20°.
- Rear view cameras are appropriately located as are three remote control work lights.
- 2-speed windshield wiper, top glass wiper
- Six-way adjustable fabric seat with headrest, seat belt
- Four-way electronic armrest mounted joysticks control swing, boom extend, main winch, auxiliary winch and boom hoist. Electronic foot pedals control the travel and swing service brake functions.
- Selectable control modes for: Fine Control, Auger, and hand control of travel functions.
- Seat and armrest termination switches immediately disable all hydraulic functions as the operator rises from the seat or lifts the left hand armrest.

Dash instrumentation: tachometer, voltmeter, oil pressure gauge, temperature gauge, hour meter and fuel gauge. Indicators are provided for crane level, load moment, drum rotation, air filter restriction, hydraulic oil temperature and filter restriction, engine oil pressure and temperature.

ENGINE

- Make/ Model: Cummins QSB 6.7
- Rating: 260 hp (194 kW) @ 2100 RPM
- Alternator: 130 amp

ELECTRICAL SYSTEM

12VDC

COUNTERWEIGHT

Total 35,000 lb (15,875 kg) rear counterweight (Two pieces)

SWING

Gear motor driving a planetary gear reducer with a shaft mounted pinion, external gear shear ball slew bearing bolted to the superstructure and the carbody allows the superstructure to rotate 360°

- Swing Speed: 0 - 2.2 rpm
- Swing Parking Brake: Spring applied failsafe brake with hydraulic release that is controlled from the operators cab
- Swing Service Brake: Hydraulically applied, controlled through foot actuated pedal
- House Lock System: 2-position, manually pinned

HYDRAULIC SYSTEM

- Hydraulic Pumps: Two high pressure, variable axial piston pumps with load sense and power limiting control for crane functions. One variable axial piston pump for cooling loop
- Directional Valves: Multiple pressure and flow compensated valves with integrated relief valves controlled by hydraulic pilot signals.
- Pump output: 154 gpm (583 l/min) @ 2100 RPM engine speed. 4,800 psi (330 bar) maximum pressure
- Filtration: 5 micron.

SIDE FRAMES

Two welded steel side frames are paired with a track group. The side frames extend and retract hydraulically and are controlled from the cab.

- Track Rollers: Two top and twelve bottom sealed rollers on each track frame Idler: Oil filled, self lubricating with spring type tensioner
- Track Shoes: 36 inch (900 mm) 3-bar semi grouser

OPTIONAL EQUIPMENT

- Boom Extension: Lattice type, swing away
 - Length: 30 feet (9.1m)
 - Head: Two, 19-inch (483 mm) diameter cast nylon sheaves on heavy-duty roller bearings
 - Max. Lifting Height: 142 ft (43.3 m)
- Boom Jib: Lattice type, swing away, stores along boom extension
 - Length: 20 feet (6.1m)
 - Offset Angles: 15° & 30°
 - Max. Lifting Height: 162 feet (49.4 m)
- 50 ton (45t) hook block - Three 18 inch (457mm) steel sheaves, swivel hook & safety latch
- Carbody Jack System: Hydraulic cylinder jack system and pendant control to facilitate quick removal of track frames for 9' 10" (3.0 m) shipping width.
- Track Shoes: 30 inch (760 mm) 3-bar semi grouser
- Track Shoes: 31.5 inch (800 mm) flat shoe
- Auger Ready Package: Includes hoses, fasteners and stowage bracket assembly mounted to the base section of the boom with a flow capability of 34 gpm (130 l/min)
- Complete Auger Package: Adds a two speed auger motor/gear box and one 60 inch (1.52 m) kelly bar to the Auger Ready Package.
- Tool Circuit: Provides 5 gpm (23 l/min) and 10 gpm (45 l/min) at 2,500 PSI (176 bar) through a 50 foot (15.2m) twin hose reel with quick disconnect fittings to operate open center tools.
- Free Fall Hoists: All winches are available in controlled free fall configurations.
- Cold Weather Packages: Cold weather options are available for operation to -40°C (Consult factory for application support)
- Work Platform: Model WP750 - 36 in x 72 in (0.9m x 1.8m) , all steel, welded, two person platform with maximum capacity of 750 lbs (340 kg).
- Pole Claw: Heavy-duty pole claw with hydraulic clamp and tilt.
- Radio control package.
- Rotation resistant wire rope.
- Pile Driving Lead Ready Package: Includes Hydraulic valves, in-cab control pendant, and quick coupler panel.

DIMENSIONS

15010

77 Ton Tele-Boom Crawler Crane

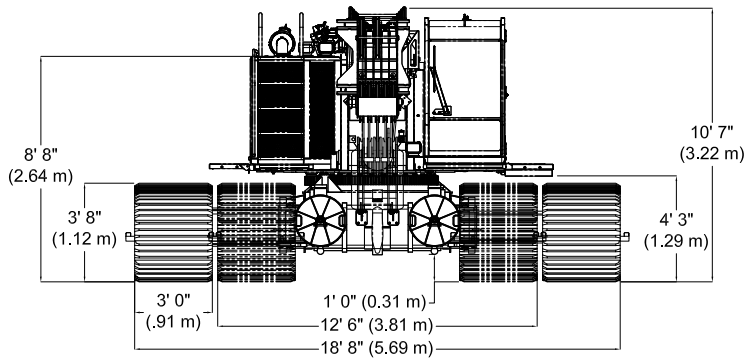
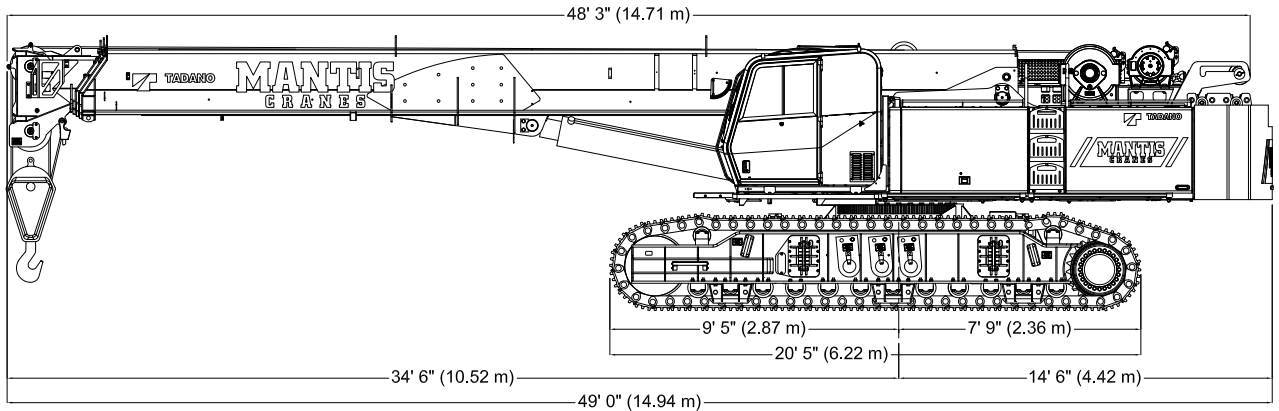

**111 FT 6 IN MAIN BOOM,
30 FT EXTENSION & 20 FT JIB**

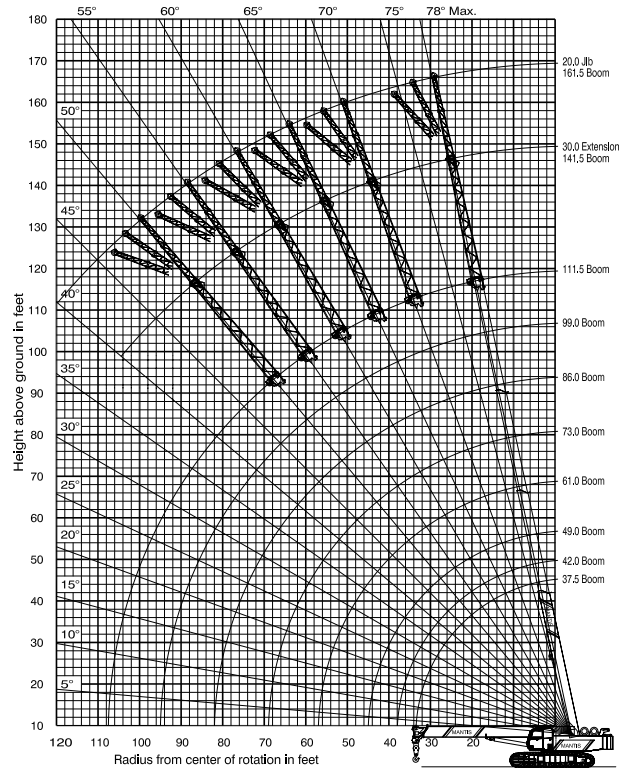

WIDTHS, WEIGHTS, AND GROUND PRESSURES*

| Shoe Width | Overall Width | | Area | Ground Pressure | Working Weight |
|-------------------|------------------------|------------------------|--|--|---------------------------|
| | Retracted | Extended | | | |
| 30 in (762 mm) | 12 ft 0 in (3.66 m) | 18 ft 2 in (5.54 m) | 12,360 in ² (7.97 m ²) | 11.0 psi (0.77 kg/cm ²) | 135,730 lb (61,419 kg) |
| 36 in (900 mm) | 12 ft 6 in (3.81 m) | 18 ft 8 in (5.69 m) | 14,850 in ² (9.57 m ²) | 9.3 psi (0.65 kg/cm ²) | 137,554 lb (62,241 kg) |

* Crane equipped with: 111 ft 6 in boom, extension, jib, 75 ton hook block and 12 ton headache ball

TADANO MANTIS CORPORATION

1705 Columbia Avenue • Franklin, TN 37064 USA • Toll-Free: 1-800-272-3325 • Fax: 615-790-6803 • mantiscranes.com



PILE DRIVING



POWERLINE