

SELF PROPELLED ROUGH TERRAIN CRANE 4 x 4 x 4

UPPERSTRUCTURE

Boom and Telescoping

- 4 section standard boom consisting of a basic boom (10 m) and 3 hydraulically powered sections (31 m). Automatic synchronization through a positive mechanical system and a single control lever. Double acting telescoping ram. No hoses inside the boom.
- Sections are longitudinally and laterally guided by bearing mounted rollers.
 - Continuous telescoping stroke : 21 m.
 - Telescoping capacity (out or in) : 30 T.
 - 2 speed ranges : 54 secs and 88 secs.
- Optional : 8.10 lattice extension folded alongside the main boom for transport - 4.70 m fly-jib (2 positions 0° and 20°) folded under the extension.

Derricking system

- Single double acting ram. Negative boom angle for easy raising and servicing of boom head. Boom angles maxi : 82° - mini : - 5°.
- Two speed ranges : 36 secs or 73 secs (- 5° up to + 82°).

Main winch and auxiliary winch (optional)

- P.P.M. type winch high pressure hydraulic motor and single reduction gear. Grooved drum and cable press device standard. Safe braking system : spring applied, hydraulically released, multi disc type. Non return spring clutch.

	Motor	Auxiliary (opt.)
Motor (rpm)	80	54.8
Reductor	1/32,4	1/25,5
Max. line pull (1st layer)	6 T	4.2 T
Speeds (4th layer) (mm/m)	0-77 0-115 0-154	0-55 0-110
Ø cable length	13 mm/150 m	15 mm/150 m
Drum Ø	420 mm	330 mm

Slewing

- By hydraulic motor through reduction gear and electromagnetic brake release. Cross-roller slewing ring with external gear teeth mounted and bolted on machined surface. Transport lock, pneumatically operated from the cab.
- Slewing speed : 0 to 2 r.p.m.

Operator cab

Full all round vision, electric windscreen wiper and washer, cab interior light, working light, adjustable seat, independent cab heater, electric horn.

Cab controls and instrumentation

- Front panel with electric warning lights and controls for engine, cab heater, windscreen wiper and washer, lighter.
- Crane controls through 4 short levers and 2 interconnected pedals for independent or simultaneous operation of crane functions. Hoisting, derricking and telescoping controls are fitted with electric switches to provide 2 speed ranges.

CHASSIS AND TRANSMISSION

Chassis

Specific P.P.M. chassis. Made from high strength steel. Unitary welded torsion box construction with integral outriggers housing. Fitted with rigid and removable deck plate (with non slip protection). Towing bracket with pin on front and rear. Lateral tool box.

Outriggers

Independent type 4 horizontal beams and 4 vertical jacks mounted upside down with fixed rods protected by sleeves and fitted with bolt. On lock valves. Long vertical stroke (850 mm) Partial extension facility.

Engine

Diesel DEUTZ F6L413F - 182 HP DIN (132 kw) at 2500 r.p.m. Air cooling. Fuel tank capacity : 220 l. Electric level gauge.

Transmission

Torque converter and power shift gear box directly flanged to the engine with 6 speeds (2 x 2) forward and reverse. Two wheel drive (4 x 2) on road and 4 wheel drive (4 x 4) off road selection from cab. Automatic rear axle disconnection in high range.

Rear and front axles

- Double reduction steering drive axles with planetary type reduction in the hubs.
- No spin differential on rear axle.

Suspension

- Front : axle fixed to the chassis.
- Rear : helicoil springs and hydraulic shocks absorbers, lockable in any position from the cab for free-on-wheel drives.

Tyres

- Standard : 26.5 x 25
- Optional : 29.5 x 25.

Steering

- Front : Hydrostatic with steering wheel.
- Rear : Hydro-electric controlled by independent lever located under the steering wheel.

Braking

- Service brakes (pedal) : Air operated on all wheels.
- Emergency and parking brakes : lever control, spring action on front wheels with pneumatic release.

CIRCUITS

Hydraulic

- Two main pumps with power take-off mounted on engine (4 x 46 l) can be automatically disconnected from the cab for travelling.
- Triple pump for steering, slewing, telescoping and outriggers.
- Separate selector blocks ensuring independent feeding flows for combining motions of the boom, winch and slewing.
- 725 l hydraulic oil tank with filter and sight-level gauge.

Electric

24 volt equipment. Two 12 volt batteries (160 Ah each) and alternator with integral electronic regulator. Specific wiring for chassis and upperstructure with separate and pre-wired modules connection boxes and instrument panels. Multicolour cables with plug-in connections and simple identification with number guide marks. Fuses grouped in 2 locations (chassis and turret cab). Complete road working equipment and lighting system.

Air circuit

Single cylinder air compressor (169 cm³). Air regulator, anti-freeze device, automatic dryer, tyre inflating connection. Separate air tanks (3 x 36 l) for service brakes, emergency and parking brakes, and general service.

SAFETY DEVICES

- Safety lock valves bolted on all load bearing cylinders (derricking, telescoping, outriggers).
- Hydraulic speed limiter on all load lowering motions (hoisting, derricking, telescoping).
- Block to block limit switch.
- Boom length and boom angle indicator.
- Mechanical lock of the upperstructure. Power operated.

OTHERS OPTIONS

- Safe load indicator.
- Lower stroke hook limiter.
- Climatic adaptations.
- Sound-proofing according to regulations.
- Special adaptations to customer requirements.

NOTE : P.P.M. reserves the right to modify the above specifications which are given as a guide only. (Figures in accordance with metric system).

50 METRIC TONS
50 TONNES METRIQUES

MAIN BOOM / FLECHE PRINCIPALE
*** ON OUTRIGGERS FULLY EXTENDED - OVER 360°**
*** CHARGES SUR STABILISATEURS EN EXTENSION TOTALE - 360°**

	FULLY SYNCHRONISED BOOM FROM 10 m TO 31 m FLECHE ENTIEREMENT SYNCHRONISEE 10 m à 31 m														
	RED ROUGE		PURPLE VIOLET		BLUE BLEU		WHITE BLANC		GREEN VERT		YELLOW JAUNE		BLACK NOIR		
	10 m		13,50 m		17 m		20,50 m		24 m		27,50 m		31 m		
	∠°	⊞	∠°	⊞	∠°	⊞	∠°	⊞	∠°	⊞	∠°	⊞	∠°	⊞	
3	66,50	50,00	73,00	41,00	76,00	36,00	78,00	25,80	81,00	23,25					3
3,5	63,50	44,90	70,50	41,00	74,50	36,00	77,00	26,90	79,50	23,25	80,00	15,80			3,5
4	60,50	40,55	68,50	40,85	72,50	36,00	76,00	26,90	78,00	22,35	79,00	15,80	80,00	12,30	4
4,5	57,50	35,95	67,50	35,95	71,00	35,45	74,50	25,75	77,00	21,30	78,00	15,80	79,00	12,30	4,5
5	54,50	32,00	64,00	32,00	69,00	32,00	73,00	24,45	75,00	20,35	77,00	15,80	78,00	12,30	5
6	47,50	26,10	60,00	26,10	65,50	26,10	70,00	22,15	73,50	18,60	75,00	15,40	76,50	12,30	6
7	39,50	21,85	54,50	21,85	62,00	21,85	67,00	20,00	71,00	17,10	73,00	14,40	74,50	11,95	7
8	27,00	18,65	49,50	18,65	58,00	18,65	64,50	18,15	68,50	15,70	71,00	13,45	73,00	11,30	8
9			43,50	16,65	54,00	16,45	61,50	18,20	66,00	14,55	69,00	12,65	71,00	10,00	9
10			37,50	14,60	50,00	14,70	58,00	14,45	63,00	13,45	67,00	11,80	69,50	10,00	10
11			30,00	12,60	45,50	13,30	54,50	13,00	60,00	12,55	65,00	11,00	67,50	9,50	11
12			16,00	11,40	40,50	11,40	51,00	11,25	57,50	11,15	62,50	10,35	65,50	8,85	12
13					35,00	9,60	48,50	8,80	54,50	9,60	60,50	8,75	63,50	8,50	13
14					28,00	8,20	44,00	8,55	51,50	8,35	58,00	8,75	61,50	8,05	14
15					19,00	7,30	39,50	7,55	48,50	7,40	55,50	7,75	59,50	7,60	15
16							35,00	6,70	45,00	6,60	52,50	6,85	56,50	6,70	16
17							23,00	6,00	42,00	5,95	49,50	6,00	55,00	5,85	17
18							20,00	5,25	38,50	5,25	46,50	5,25	52,50	5,20	18
19							13,00	4,60	34,50	4,75	43,50	4,70	50,00	4,70	19
20									30,00	4,20	40,00	4,15	47,50	4,10	20
21									24,50	2,65	37,00	3,70	45,00	3,65	21
22									17,00	3,30	33,50	3,35	42,50	3,30	22
23											29,50	3,00	39,50	3,00	23
24											24,50	2,65	36,50	2,65	24
25											19,50	2,35	33,00	2,35	25
26											13,00	2,15	29,00	2,05	26
27													24,50	1,85	27
28													19,00	1,60	28
29													13,00	1,45	29

10-17,5 m EXTENSION / EXTENSION 10-17,50
*** ON OUTRIGGERS FULLY EXTENDED - OVER 360°**
*** CHARGES SUR STABILISATEURS EN EXTENSION TOTALE - SUR 360°**

	MAIN BOOM + 10 m EXTENSION FLECHE PRINCIPALE + EXTENSION 10 m				MAIN BOOM + 17,50 m EXTENSION FLECHE PRINCIPALE + 17,50 m EXTENSION				
	0°		30°		0°		30°		
	∠°	⊞	∠°	⊞	∠°	⊞	∠°	⊞	
6	81,50	7,60							6
7	81,00	7,35			81,50	4,30			7
8	80,50	7,05			81,00	4,25			8
9	79,50	6,70			80,00	4,15			9
10	78,50	6,35	81,50	4,45	79,50	4,00			10
11	77,50	6,00	81,00	4,40	78,50	3,90			11
12	76,00	5,70	80,50	4,30	78,00	3,80			12
13	74,50	5,40	79,50	4,20	77,00	3,70			13
14	73,50	5,20	78,50	3,95	76,00	3,60			14
15	72,00	4,95	77,50	3,80	75,50	3,45			15
16	70,00	4,70	76,00	3,70	74,50	3,35			16
17	68,50	4,50	75,00	3,50	73,50	3,25	81,50	2,20	17
18	66,50	4,30	73,00	3,40	72,50	3,20	80,50	2,15	18
19	65,00	4,15	71,50	3,30	71,50	3,10	79,50	2,10	19
20	63,00	3,65	70,00	3,20	70,00	2,95	78,50	2,05	20
21	61,00	3,20	68,00	3,10	69,00	2,90	77,50	1,95	21
22	59,00	2,80	66,00	2,95	67,50	2,80	76,50	1,85	22
23	57,00	2,45	64,00	2,90	66,50	2,75	75,50	1,90	23
24	55,00	2,20	62,00	2,80	65,00	2,65	74,50	1,80	24
25	53,00	1,95	60,00	2,65	63,50	2,60	73,00	1,85	25
26	51,00	1,75	58,00	2,35	62,00	2,45	71,50	1,85	26
27	49,00	1,55	56,00	2,10	60,50	2,35	70,00	1,80	27
28	47,00	1,45	54,00	1,80	59,00	2,10	68,50	1,80	28
29	45,00	1,30	52,00	1,55	57,50	1,85	67,00	1,75	29
30	43,00	1,20	50,50	1,35	55,50	1,65	65,00	1,75	30
31			48,50	1,10	53,50	1,45	63,50	1,75	31
32			46,50	0,90	51,50	1,20	61,50	1,70	32
33					49,50	1,05	59,50	1,65	33
34							57,50	1,45	34
35							55,50	1,20	35

On firm and level ground and wheels raised clear of the ground. / Avec roues décollées du sol, sur sol dur et horizontal.
 Boom length indicating colours / Couleur de repérage des longueurs de flèche

07 85 1 S 06515-83

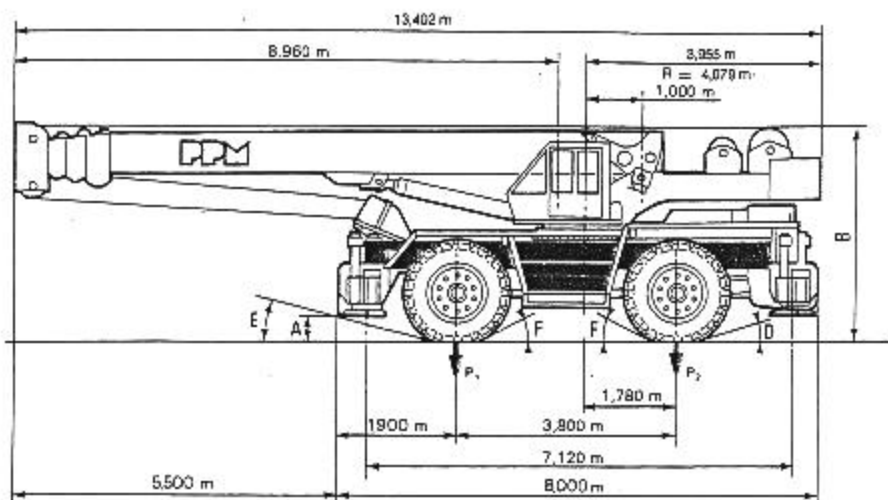

	A	B	C	D	E	F
26,5 x 25	0,385 m	3,79 m	3,22 m	18°	23°	25°
29,5 x 25	0,445 m	3,88 m	3,305 m	20°	24°	26°

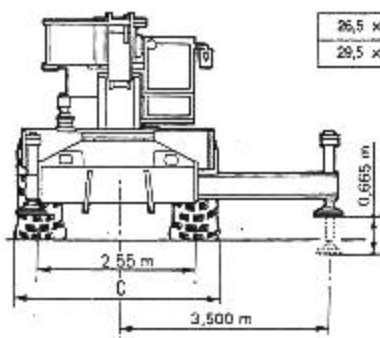

Poids / Weight / Gewicht / Peso			
Machine de base Basic machine Maquina de base Grundgerät	39,75 t	Toutes options All options Todas opciones Zusausaüstung	41,5 t
P ₁ : 18,7 t	P ₂ : 20,05 t	P ₁ : 21,5 t	P ₂ : 20 t

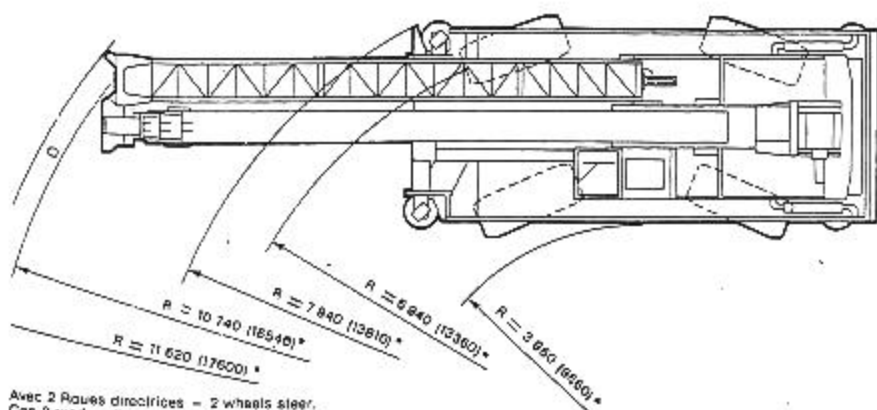

Avec 2 Roues directrices - 2 wheels steer.
Con 2 ruedas directrices - 2 Lenkräder.