

ETC MH37 IH

ARTICULATED / TELESCOPIC INSULATED MATERIAL HANDLING



INSULATED VERSATILITY

The ETC37MH is a versatile insulated unit that is well suited to those customers in need of an aerial unit that can offer powerful capabilities. With an articulating and telescoping aerial lift that reaches a height of 37' to the bottom of the bucket, this unit has a standard option continuous rotation allowing for unrestricted rotation. This model also offers material handling capabilities with a hydraulic winch and a 5' jib that can lift up to 1,000 lbs. utilizing the full 27 ft - 5 in. of hydraulic reach.



DEPEND ON IT.™



ETC MH 37 IH

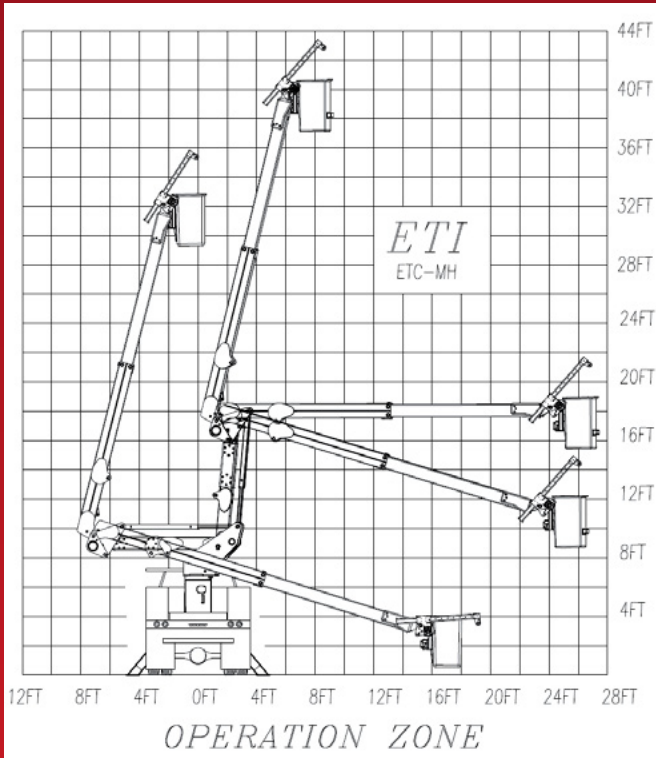

**EQUIPMENT TECHNOLOGY LLC
IS A FULL SERVICE SOLUTION
PROVIDER OF THE HIGHEST
QUALITY DESIGN,
MANUFACTURING, AND POST
SALE SERVICE.**

EQUIPMENT TECHNOLOGY LLC

341 NW 122nd
Oklahoma City, OK 73114
Toll-Free: 1-888-748-3841 • Fax: 1-405-755-6829
etiequipment.com

GENERAL SPECIFICATIONS*

Height to bottom of bucket	37 ft. - 0 in.
Working height	42 ft. - 0 in.
Side reach, End mount	27 ft. - 5 in.
Rotation	Continuous
Lower boom articulation	0° to 95°
Upper boom travel	-17° to 76°
Stow height	10 ft. - 2 in.
Rated bucket capacity	400 lbs.

MINIMUM VEHICLE SPECIFICATIONS

- GVWR 19,500 lbs.
- C.A. 84 in.

STANDARD FEATURES

- Continuous rotation is standard providing unrestricted rotation.
- Lower boom compensating link.
- Full pressure hydraulic controls located at platform and turret with full feathering capabilities from upper and lower controls.
- Hydraulic leveling via master/slave system providing a bucket dump for clean out and operator rescue.
- Shear ball rotation gear driven by external drive gear box. The gear box has an extended hex shaft for manual rotation.
- Internally mounted holding valve (integral part of cylinder) locks cylinder in place in event of hydraulic failure.
- All pins turn on replaceable composite bushings.
- Inner boom extend with double acting hydraulic cylinder for safety and performance.
- 90 Degree bucket rotator
- Single handle hydraulic control at basket.
- Fiberglass upper boom, fiberglass insert on lower boom.
- 24"x 30" Basket
- 2 sets of outriggers
- Outrigger/boom interlock
- 400lbs. Bucket capacity
- Hydraulic winch & 5ft jib—up to 1000lbs. material handling

OPTIONS

- Engine start/stop at bucket
- Emergency hydraulic power (12VDC)
- Hydraulic tool circuit
- Bucket liner
- Bucket cover
- Hydraulic jib extension



Specifications are subject to change without notice
Note (*): All specifications are based on 40" frame height