

LIBERATOR 5000H

25,000 ft-lbs Crane Rating



Designed
to a
Higher Standard

Better by design

ETI is committed to designing and manufacturing the best electric hydraulic crane value in the industry. Our cranes are innovatively designed to perform to a higher standard of durability and reliability, and to provide the maximum duty cycle possible in an electric crane. We've backed that commitment with our limited lifetime structural warranty and factory direct technical support. You can be assured that your new Liberator crane will provide many years of dependable service.

ETI
A PALFINGER Company

LIBERATOR 5000H

Liberator 5000H cranes come complete with wireless proportional remote control with an optional-usage wire tether, mounting bolts and owner's manual are also included.

Minimum chassis size, 10,500 GVW.

Maximum lifting capabilities

5000 lbs	5'
4166 lbs	6'
3571 lbs	7'
3125 lbs	8'
2500 lbs	10'
2083 lbs	12'
1785 lbs	14'
1562 lbs	16'
1388 lbs	18'
1250 lbs	20'

Features

- Automatic overload protection prevents hoist up, boom extension and boom down.
- Anti-two-block system is standard.
- Large diameter, self-locking, all steel worm gear rotation drive is mounted on steel slewing ring crane bearing and provides 400 degree power rotation.
- Load cushioning counterbalance/check valves on all cylinders for precise load holding and handling.
- Safety valves on all cylinders prevents load drop if hose fails.
- Powder coat finish for high gloss and durability.
- Trigger operated wireless proportional speed control of all functions.
- All boom function valves have manual override capability.
- 30' tether for non-radio operation or back-up battery operation.
- Planetary gear hoist is on it's own dedicated circuit and is designed for maximum power and hook speed control.
- 85ft of 5/16" wire rope. Hoist drum and wire rope are on the outside of the boom where they are visible to the operator.
- Polymer wire rope pulleys reduce wire rope wear and are permanently lubricated.
- Boom extensions slide on low friction self-lubricating polymer slide pads.
- Meets OSHA 1910.180 requirements, and ANSI B30.5 safety standards.
- Hydraulics powered by truck engine, 10 GPM, 2800 psi., 25gal reservoir minimum.
- Mounting bolts and nuts provided (4 ea. 7/8" grade 8).

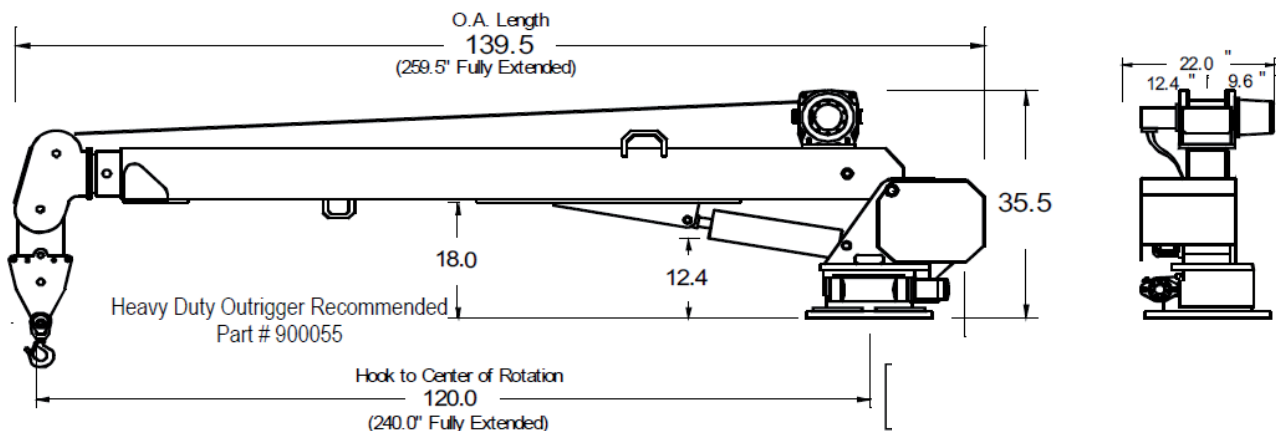

Model	Power Boom	Power Extend	Manual Extend	Weight	O.A. Length Retracted	O.A. Width
LIB 5000H LS	Yes	10' to 22'	No	1450 lbs	11' - 4 1/2"	22"