

CLASSIC



	12021	12022	12023	12024	12025	12023 +J11	12023 +J12
Maximum lifting moment Momento del elevación máxima	ft lbs 82540	79920	77080	75450	69200	-	-
Maximum hydraulic reach Alcance hidráulico	horizontal - horizontal ft 20'10"	27'1"	33'8"	40'2"	46'5"	46'3"	50'10"
vertical - vertical ft 31'2"	37'7"	43'6"	50'0"	56'1"	55'9"	60'4"	
Maximum reach with manual extensions Alcance con prolongas manuales	horizontal - horizontal ft -	-	52'2"	52'6"	52'6"	55'7"	55'7"
vertical - vertical ft -	-	-	60'8"	61'0"	61'0"	64'12"	64'12"
Hydraulic system - Sistema hidráulico	recommended oil flow - caudal requerido gals/min 8	8	8	8	8	8	8
rated pressure - presión máxima Psi 3990	3990	3990	3990	3990	3990	3920	3990
tank capacity - capacidad del depósito de aceite Gals 23	23	23	23	23	23	23	23
Slewing system - Sistema de giro	slewing angle - ángulo de giro ° 390	390	390	390	390	390	390
slewing moment - momento de giro ft lbs 11800	11800	11800	11800	11800	11800	11800	11800
max. working heel - inclinación máxima de trabajo %(°) 8,7(5)	8,7(5)	8,7(5)	8,7(5)	8,7(5)	8,7(5)	0	0
Standard crane weight - Peso de la grúa est	Empty oil tank - deposito de aceite vacío lbs 3042	3285	3516	3726	3946	4034	4189
LC version - LC version	Empty oil tank - deposito de aceite vacío lbs 3131	3351	3549	3792	-	-	-



Cod. 836.696 EID - 07



- PM crane in LC version, with first hydraulic retractable boom, optimizes the load positioning close to the column, and makes easy the placement of heavy and bulky loads.
- En la versión LC, el primero brazo se recoge hidráulicamente, así que permite de elevar, mover y también colocar material pesado y de grande tamaño cerca de la columna.

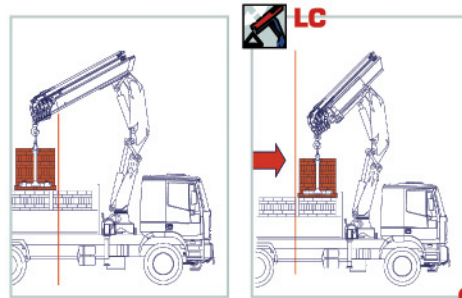

- Up to 5 hydraulic extensions available.
- Disponible hasta 5 extensiones hidráulicas.

- Jib with 1 and 2 extensions on 3 extension crane version.
- Jib con 1 y 2 extensiones en la grúa del model con 3 extensiones.

- Manual extensions on crane and jib with LMU device (opt).
- Prolongas manuales sobre la grúa y antenas con dispositivo LMU (opt).

- Stabilizers with manual and hydraulic extension, extendable up to 16'5" ft.
- Brazos estabilizadores con extensión manual y hidráulica que ofrecen un alcance máximo de 5 m.



ACCESSORIES - ACCESORIOS

New



Heat exchanger.
Cambiador de calor.

New

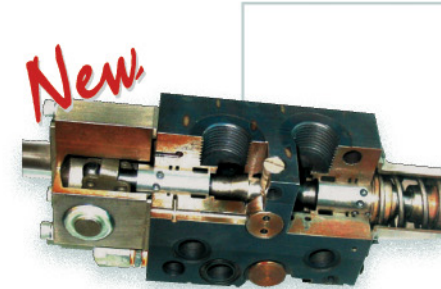

Have proportional hydraulic control valve block.
Distribuidor hidráulico proporcional Hawe.



Raised control station: maximum angle of visibility.
Puesto de maniobra en pie: máximo ángulo de visibilidad.

PQS

CERTIFIED PAINTING QUALITY SYSTEM
SISTEMA DE BARNIZADO DE CALIDAD CERTIFICADA

[3]

3 YEARS OF WARRANTY ON THE STRUCTURAL PARTS
3 AÑOS DE GARANTÍA POR LAS PARTES ESTRUCTURALES

New



Scanreco multifunction radio control.
Radiocontrol multifunción Scanreco.



Hydraulic winches with a capacity ranging from 2090 lbs up to 2430 lbs on cranes.
Cabrestantes hidráulicos de 950 kg a 1100 kg en grúa.

IIIA

DECLARATION OF CONFORMITY OF THE MANUFACTURER
DECLARACIÓN DE CONFORMIDAD DEL PRODUCTOR

Slewing by rack
Rotación con cremallera de giro

LC execution
Configuración LC

Manual outrigger booms
Brazos estabilizadores a salida manual

Extension sequence boom
Salida secuencial de los brazos

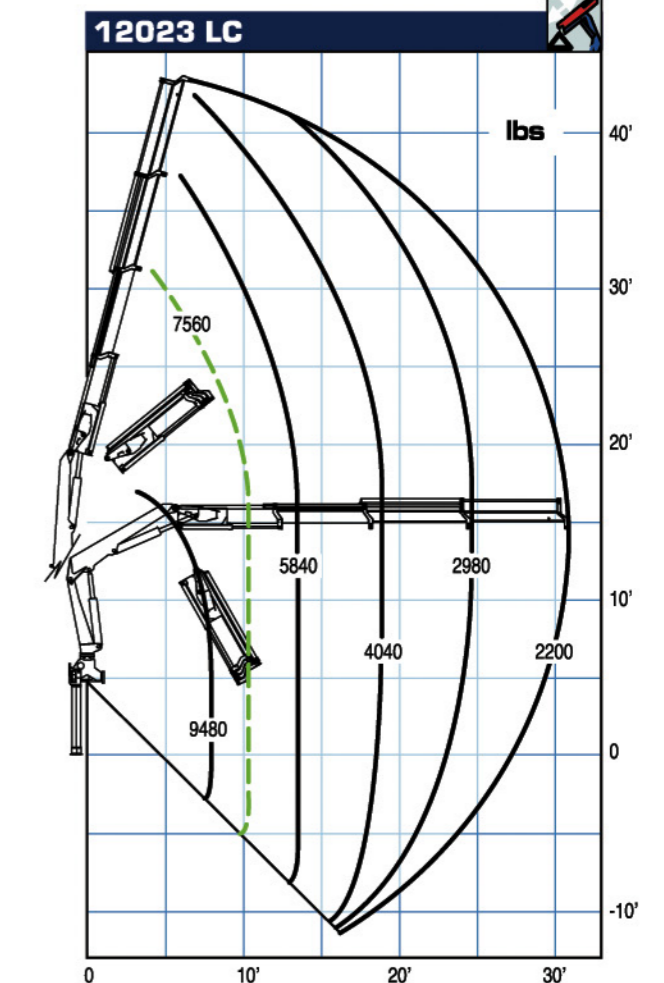
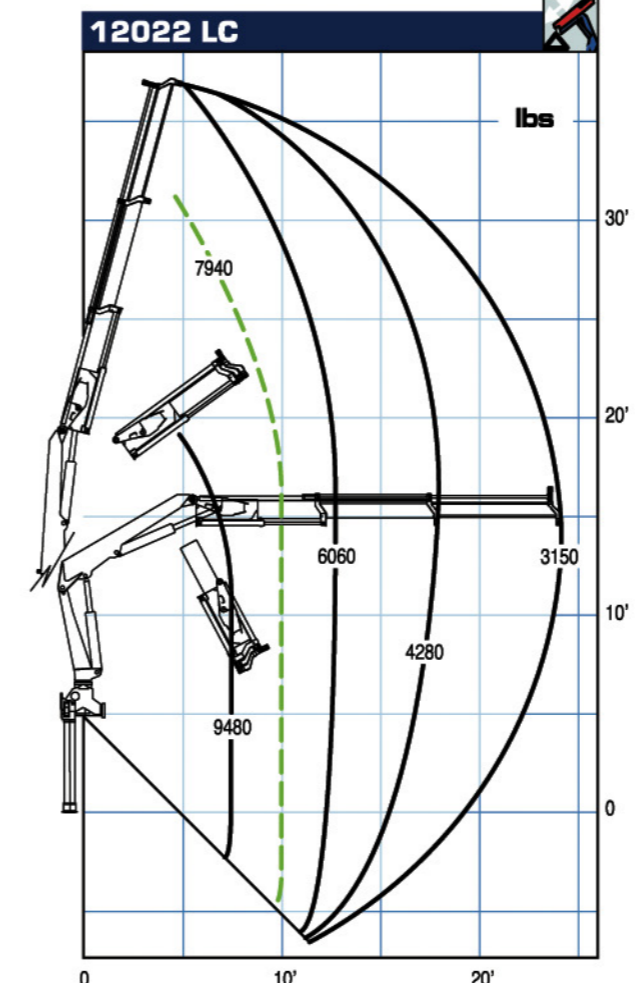
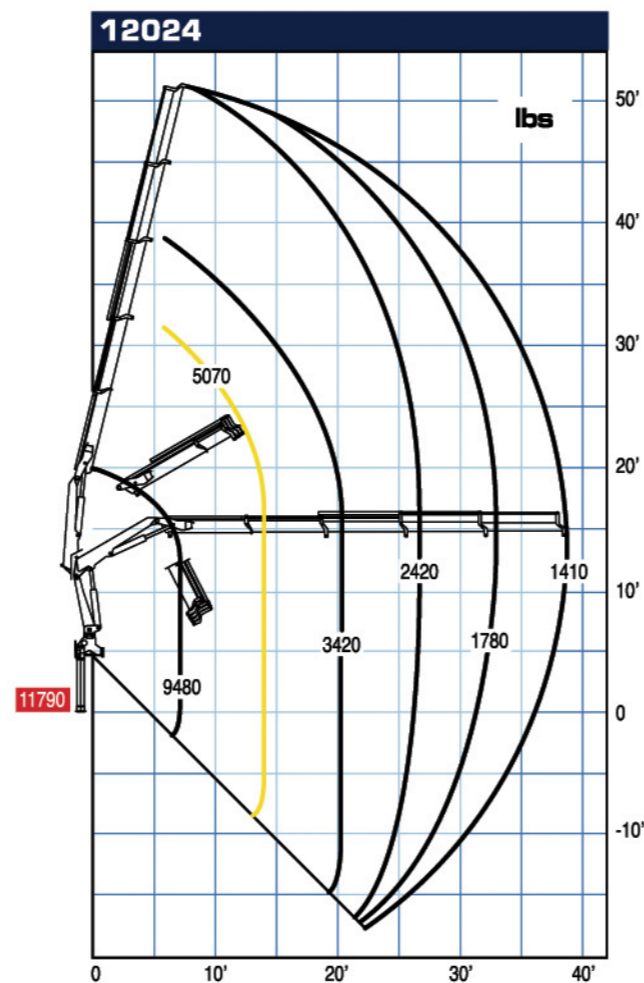
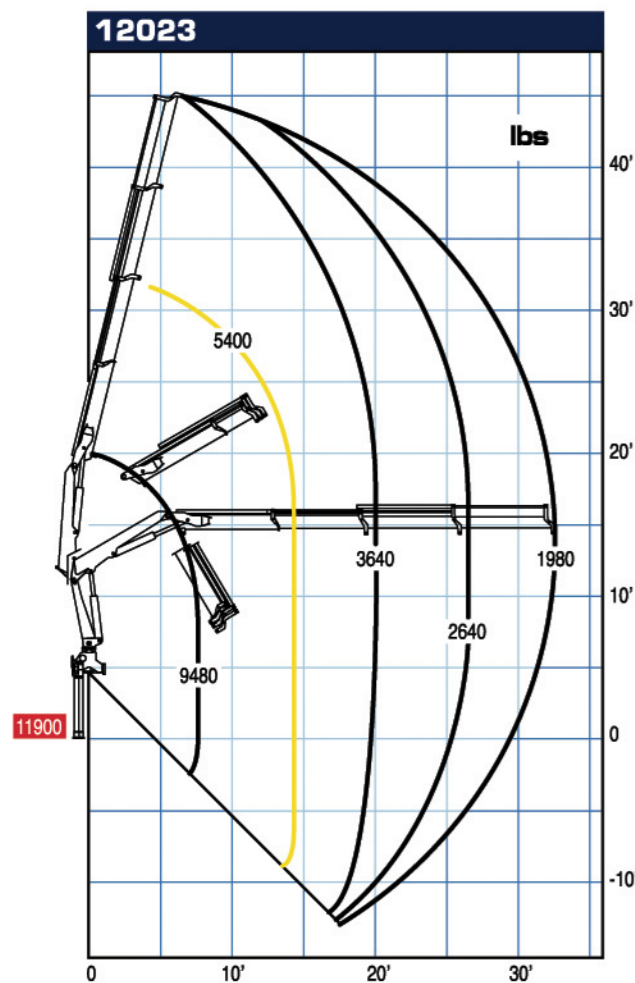
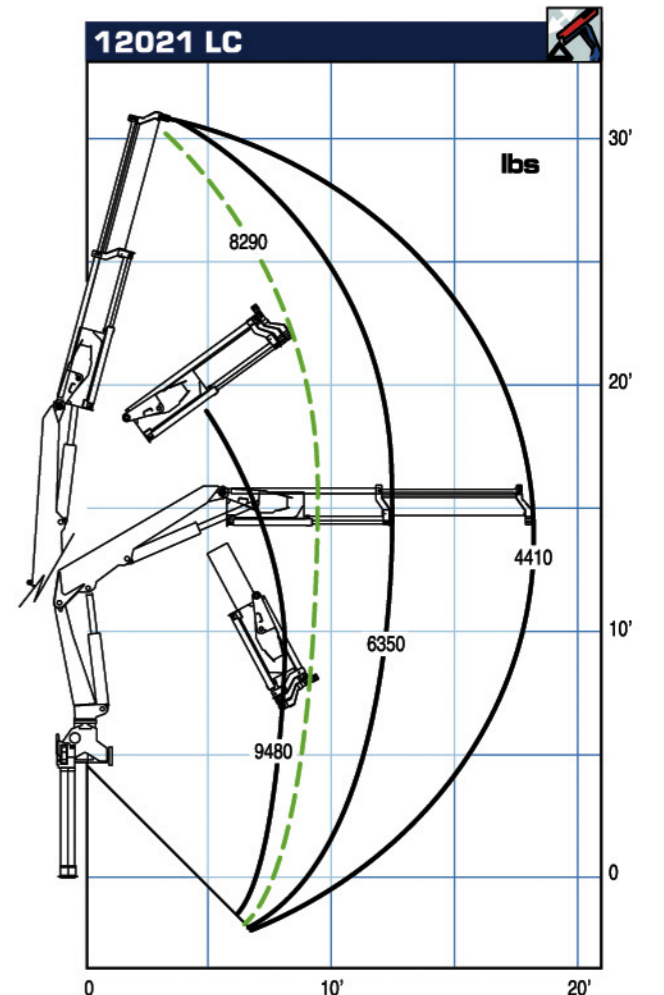
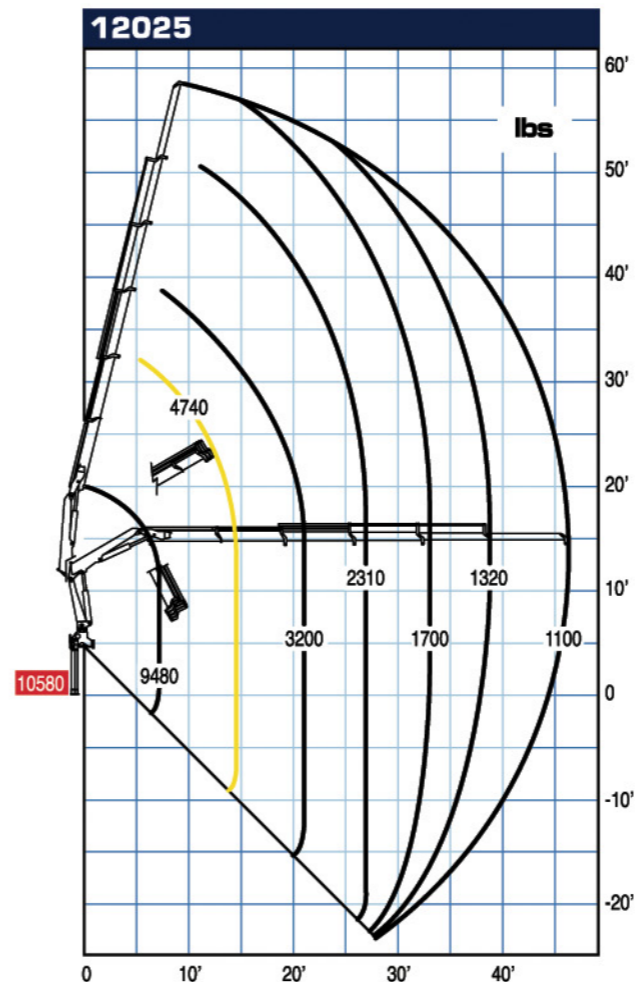
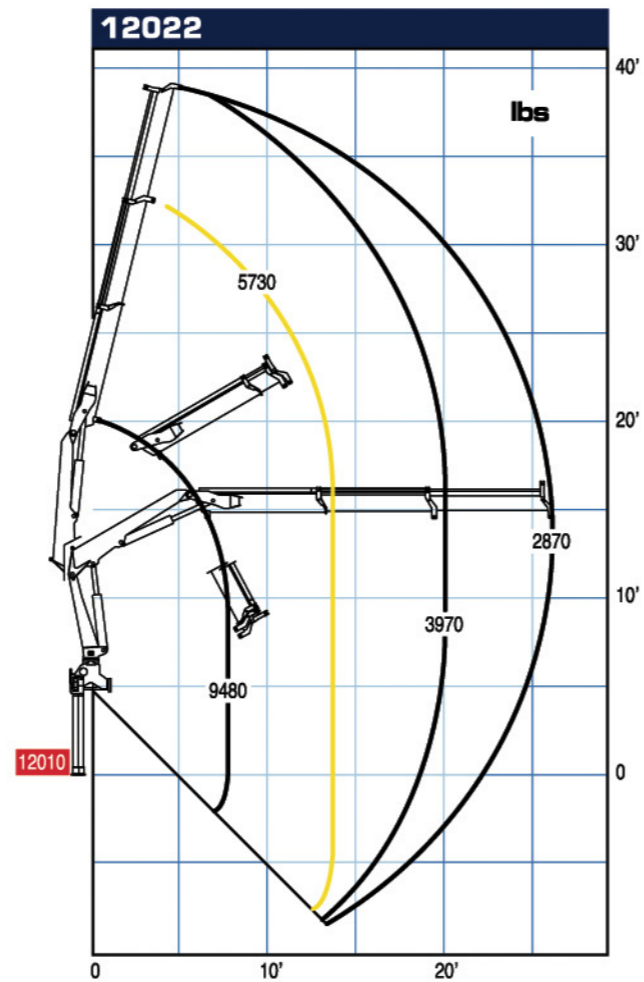
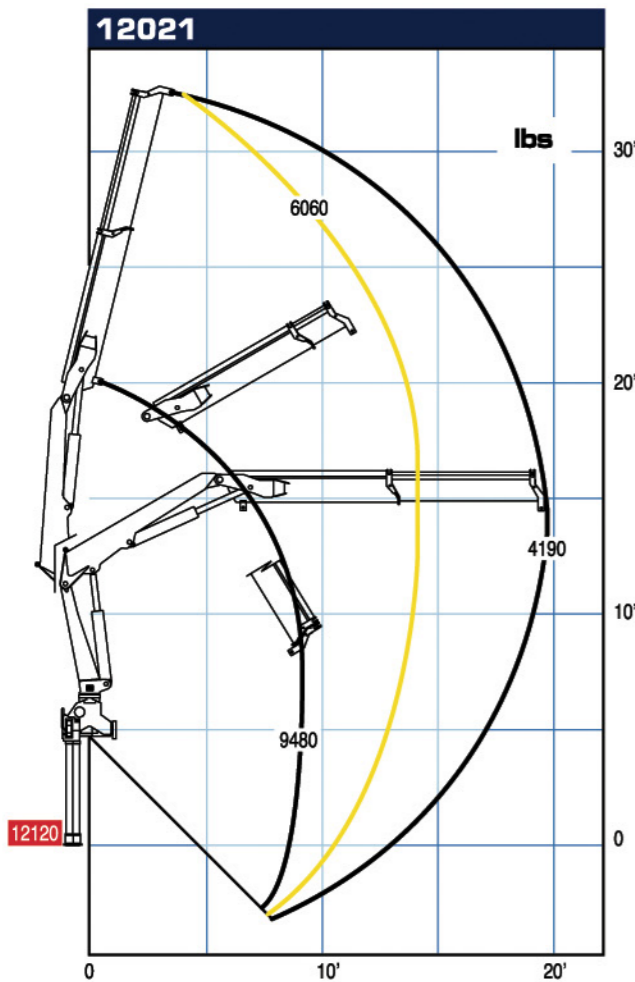

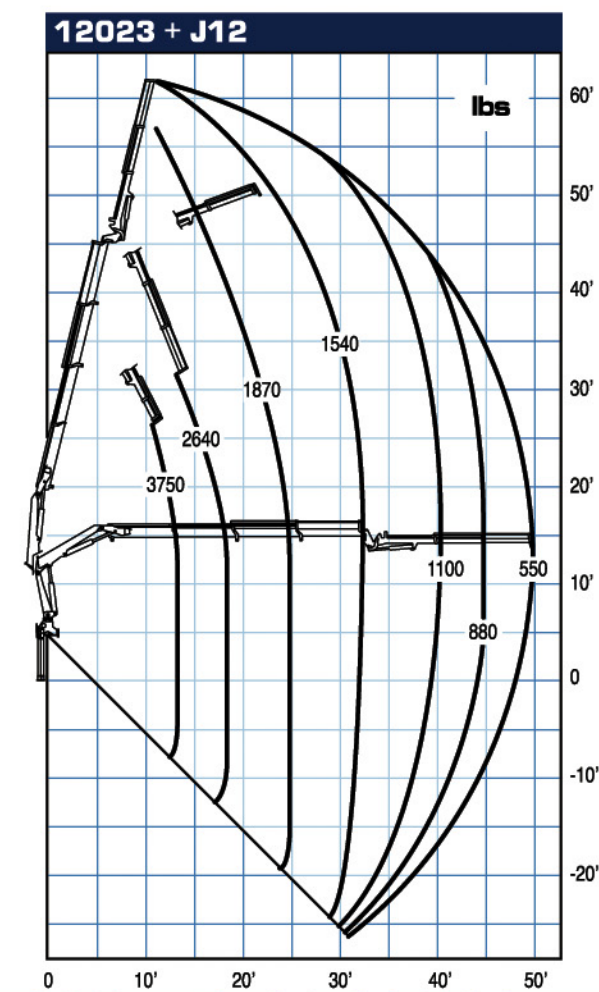
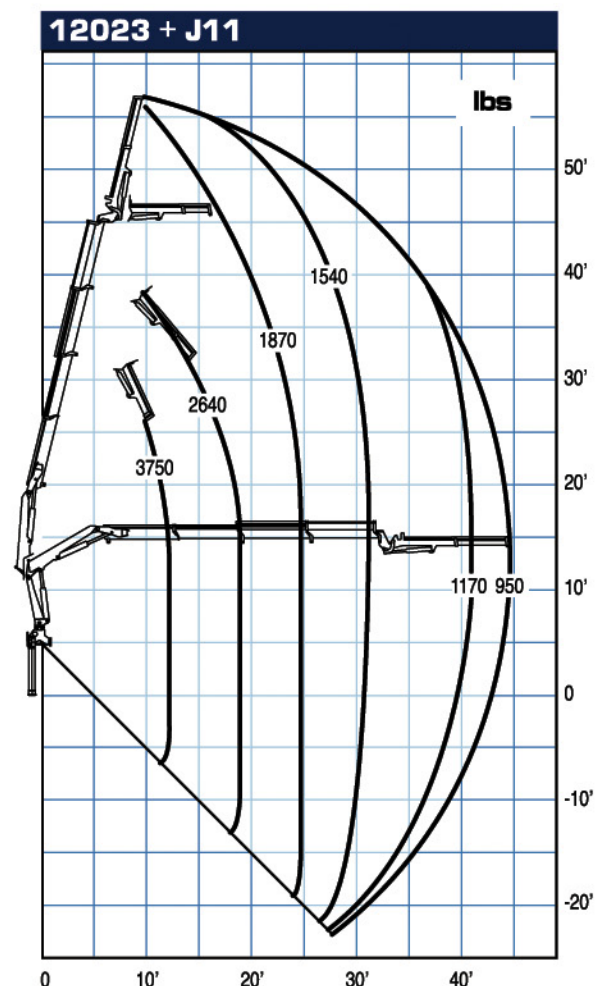
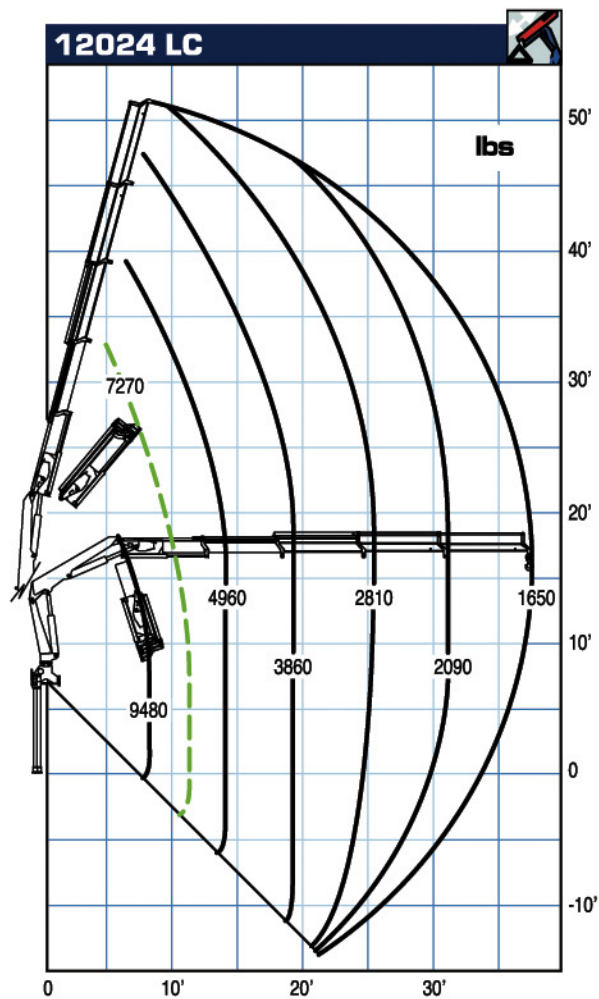

- Max. nominal capacity with fixed hook
Capacidad máxima en el gancho fijo
- Max. capacity from horizontal to vertical
Capacidad máxima en posición vertical
- - - Only LC crane version - Solo con grúa en versión LC

All PM Cranes are covered by international insurance policy for civil liability third party. - Todas las grúas PM cuentan con una póliza de seguros internacional contra las responsabilidades civiles hacia terceros.

Technical data can be revised without prior notice. - Reservado el derecho de modificaciones.

Trucking crane combination Acoplamiento grúa con vehículo	
PTT/GVW 12	4 outriggers 4 gatos de apoyo
12,0 ton	
13,5 ton	
15,0 ton	2 outriggers XL 2 gatos de apoyo XL
18,0 ton	
19,0 ton	
26,0 ton	2 outriggers STD 2 gatos de apoyo STD
32,0 ton	
44,0 ton	

PTT: G.V.W. - Peso total del vehículo



LC (Long-Short) Telescopic System Sistema telescópico LC (Largo-Corto)

The **LC System**, which has become part of the PM range, enables movement of telescopic booms within a 1st boom acting as a sheath. This is done using the same control of the boom extension cylinders and without altering the maximum outreach.

Approaching the column and raising the attachment point by approximately **80 cm** with respect to the loading surface optimises both load handling and positioning. The LC system does not reduce the extension stroke but on the contrary increases it, thus making the crane suitable for any loading position.

El **Sistema LC**, ya consolidado en la producción de PM, permite el desplazamiento de los brazos telescópicos dentro de un primer brazo a modo de vaina, utilizando el mismo mando de los gatos de esfido de los brazos y dejando invariada la distancia de alcance máximo. El acercamiento a la columna y el levantamiento del punto de enganche unos **80 cm** sobre el plano de carga permite optimizar tanto el desplazamiento como el posicionamiento de la carga.

El sistema LC no limita el recorrido del esfido sino que lo amplía, de manera que la grúa resulta adecuada para afrontar cualquier posición de carga.

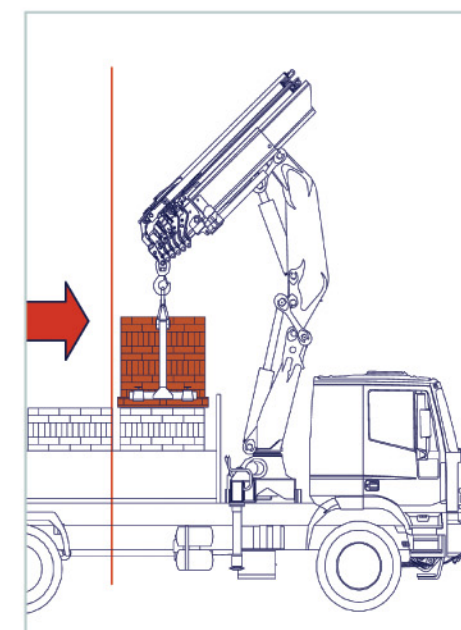
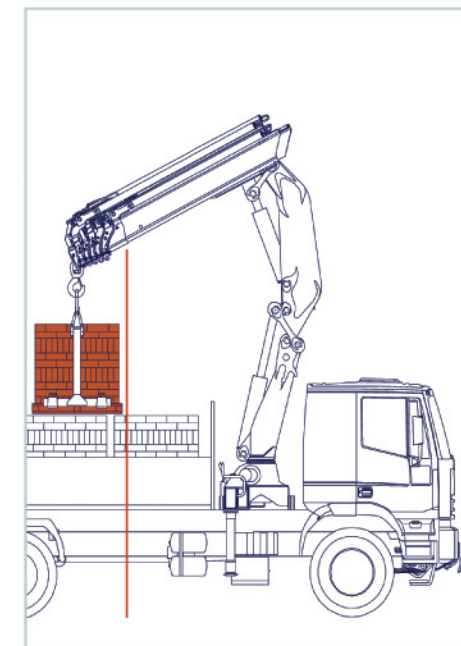



12021

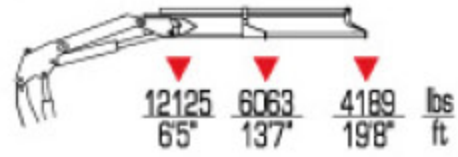

12022

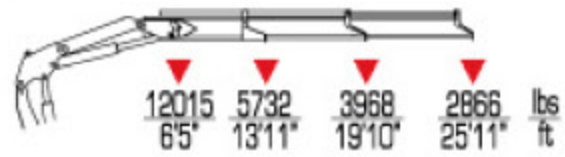

12023

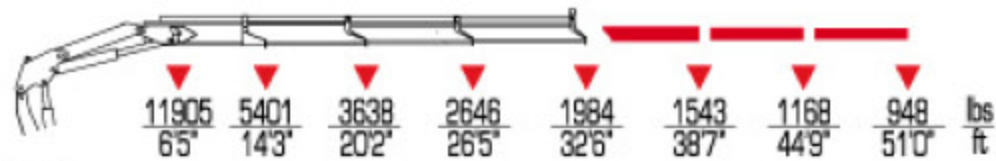

12024

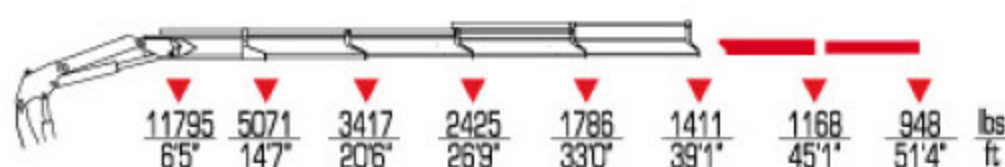

12025

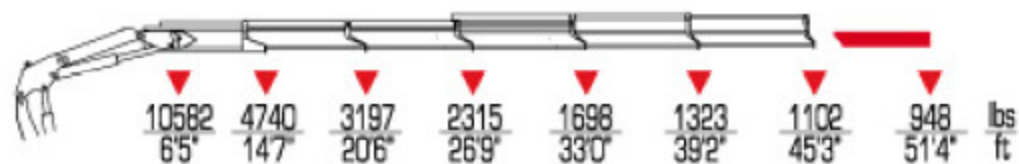

12023+J11



12023+J12



		ft lbs	OIL	gals /min	Psi		°	lbs	ST	LC				
12021		82540		8	3990		390	3042	3131	8'3"	7'	2'10"		12021
12022		79920		8	3990		390	3285	3351	8'3"	7'	2'10"		12022
12023		77080		8	3990		390	3516	3549	8'3"	7'	2'10"		12023
12024		75450		8	3990		390	3726	3792	8'3"	7'	2'10"		12024
12025		69200		8	3990		390	3946	-	8'3"	7'	2'10"		12025
12023+J11		-		8	3990		390	4034	-	8'3"	7'	2'10"		12023+J11
12023+J12		-		8	3990		390	4189	-	8'3"	7'	2'10"		12023+J12