



**“Big Red”
T-650L**

**Taylor Industrial Trucks
Standard Specifications**

Rated Capacity 65,000-lbs. **(29,484 kg)**

48-in. **(1,219 mm)** Load Center

180-in. **(4,572 mm)** Wheelbase

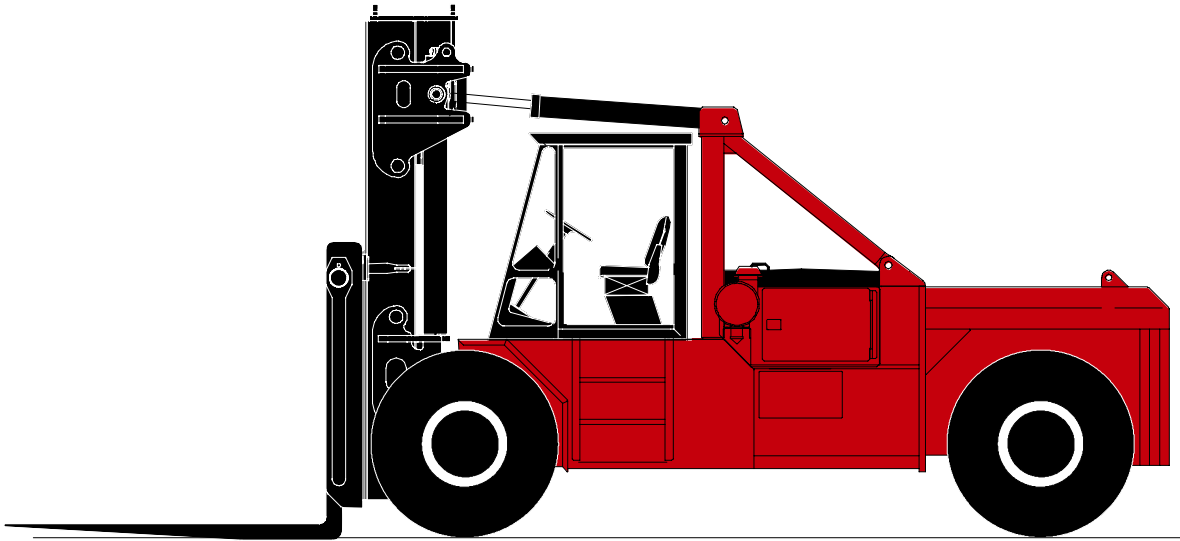

“Big Red” T-650L

GENERAL	1	Manufacturer	Manufacturer's Name	TAYLOR		
	2	Model	Manufacturer's Designation	T-650L		
				English	Metric	
	3	Capacity	Rated Capacity	lb (kg)	65,000 29,484	
	4	Load Center	Distance	in (mm)	48 1,219	
	5	Power Type	Gas, LPG, Or Diesel		Diesel	
	6	Tire Type	Cushion, Pneumatic Front / Rear		Pneumatic / Pneumatic	
	7	Wheels	Number (X = Driven) Front / Rear		4X / 2	
DIMENSIONS	8	Upright Lift	Standard Lift (Top Of Fork)	in (mm)	137 3,480	
	9	Forks	Thickness	in (mm)	5 127	
	9A		Width	in (mm)	12 305	
	9B		Length	in (mm)	96 2,438	
	10		Tilt Angle	Standard Upright - Forward / Backward	deg.°	12 / 12
	11	Overall Dimensions	Length To Face Of Forks	in (mm)	265 6,731	
	12		Width (Standard Tires)	in (mm)	134.5 3,416	
	13		Height, Standard Upright Lowered	in (mm)	160 4,064	
	14		Height, Standard Upright Extended	in (mm)	226 5,740	
	15		Height To Top Of Counterweight	in (mm)	76 1,930	
	16		Height To Top Of A-Frame	in (mm)	132 3,353	
	17	Turning Radius	Minimum Outside	in (mm)	250 6,350	
	17A		Minimum Inside	in (mm)	24 610	
	18	Load Distance	Center of Wheel To Face Of Forks	in (mm)	45 1,143	
	19	Aisle Width	(Add Load Length For 90° Stacking)	in (mm)	295 7,493	
	PERFORMANCE	20	Stability	Comply With ANSI?		Yes
		21	Speeds	Travel Speed - Maximum Forward	mph (km/h)	15.9 25.6
		22		Lift Speed - No Load	fpm (m/s)	48 0.24
		22A		Lift Speed - With Load	fpm (m/s)	42 0.21
23		Lowering Speed - No Load / With Load		fpm (m/s)	60 .3	
24		Drawbar Pull	Powershift (Maximum At Stall)	lb (kN)	33,550 149	
25	Gradeability	Powershift (Maximum At Stall) No Load	%	31.2		
25A		Powershift (Maximum At Stall) With Load	%	21.2		
WEIGHT	26	Ttl. Apprx. Wt.	Standard Truck	lb (kg)	90,600 41,096	
	27	Axle Loading	Static With Rated Load - Front	lb (kg)	141,280 64,085	
	27A		Static With Rated Load - Rear	lb (kg)	14,320 6,496	
	27B		Static With No Load - Front	lb (kg)	42,900 19,459	
	27C		Static With No Load - Rear	lb (kg)	47,700 21,637	
WHEELS / TIRES	28	Tires	Number - Front / Rear		4 / 2	
	29		Size - Front		16.00 x 25 - 24 PR	
	30		Size - Rear		16.00 x 25 - 24 PR	
	31	Wheelbase	Distance	in (mm)	180 4,572	
	32	Tread	Center Of Outside (Dual) Tires - Front	in (mm)	117.1 2,974	
	32A		Center Of Tires - Rear	in (mm)	103 2,616	
	33	Ground Clearance	No Load At Lowest Point	in (mm)	12 305	
	34		No Load At Center Of Wheelbase	in (mm)	19.4 493	
	35	Brakes	Service / Parking - Method Of Control		Foot / Hand	
	36		Service / Parking - Method Of Operation		Air / Spring	
POWER UNITS / XMSN	37	Battery	Volts / Ampere Hours (2 Batteries)	V/Ah	12 / 2300	
	38	Internal Combustion Engine	Make / Model		Cummins QSC8.3-C230	
	39		Output - Intermittent Per SAE Standards	hp (kW)	230 172	
	40		Governed Speed - With Load	rpm	2200	
	41		Cycle / Number Of Cylinders / Displacement	cu in (L)	4 / 6 / 506 4 / 6 / 8.3	
	42	Clutch	Type		Declutch	
	43	Gear Change	Type		Hand	
	44	Transmission	Number Of Speeds - Forward / Reverse		3 / 3	
	45		Type		Powershift	
	46	Relief Press.	For Attachments	psi (bar)	1500 103	
47		Width Across Counterweight	in (mm)	120 3,048		
48		Standard Fork Spread	in (mm)	120 3,048		
49		Ground To Top Of Carriage	in (mm)	90 2,286		
50		Load Moment	in-lbs (m-kg)	6,045,000 69,650		

† NOTE: Performance specifications are for trucks equipped as described on the back page of this specification sheet. Performance specifications are affected by the condition of the vehicle, its components, and the nature and condition of the operating area. If these specifications are critical, the proposed application should be discussed with your Taylor sales representative.

“Big Red” T-650L

Mast Dimensions (inches / millimeters)						
2-Stage ULTRA-VU Telescopic Mast	Optional Lift Height (8)		OAHL (13)		OAHR (14)	
	English	Metric	English	Metric	English	Metric
	137	3,480	160	4,064	226	5,740
	161	4,089	172	4,369	250	6,350
	185	4,699	184	4,674	274	6,960
	221	5,613	202	5,131	310	7,874

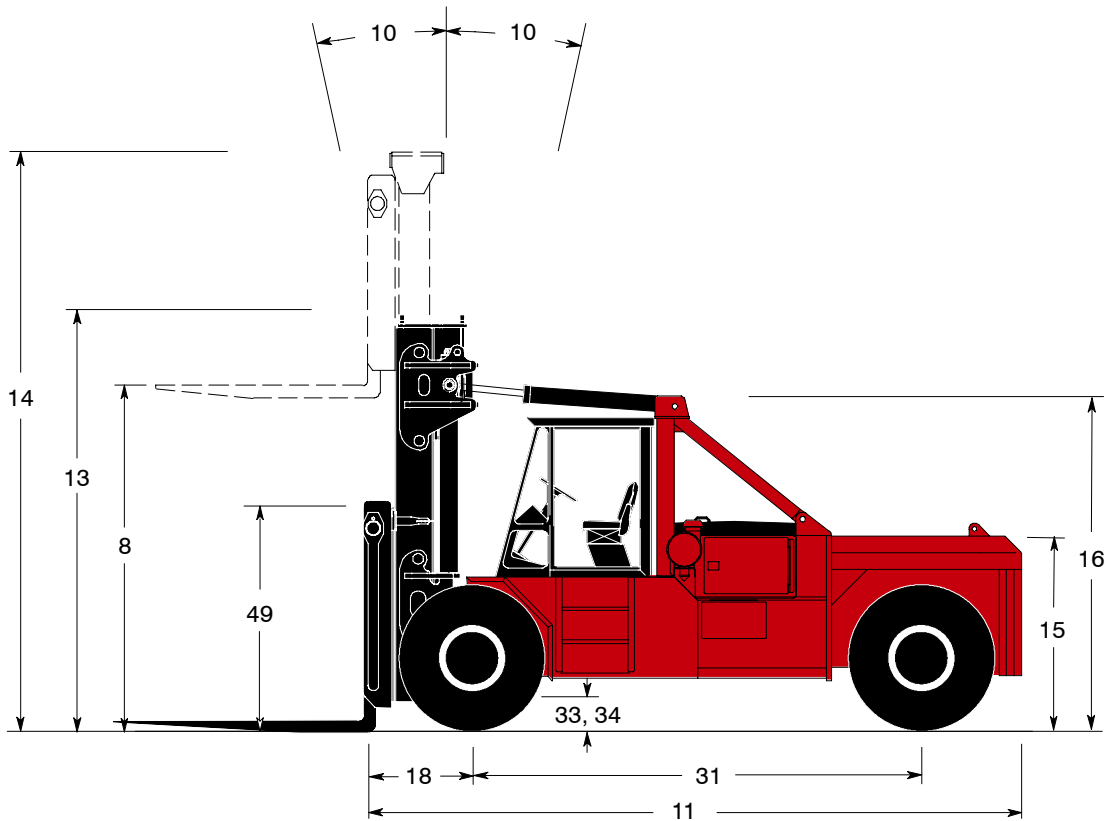
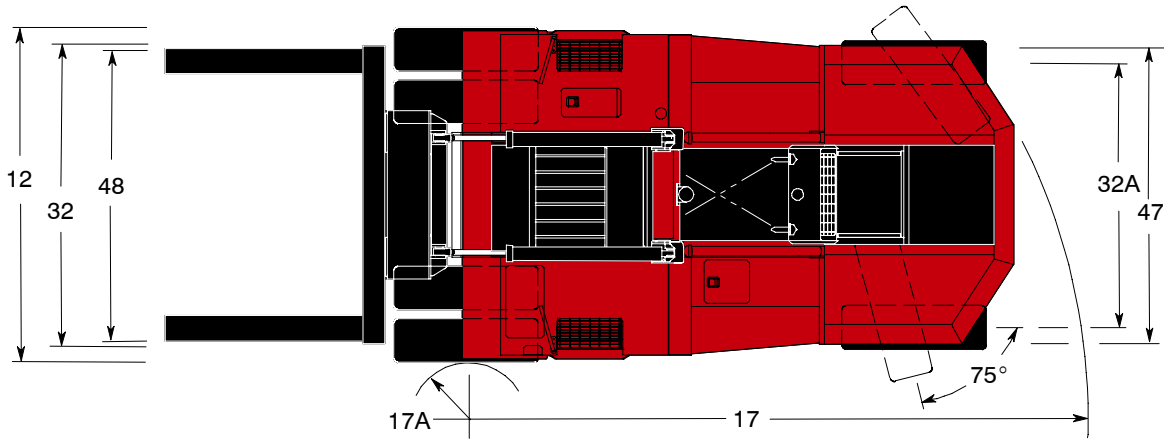

“Big Red” T-650L

Engine

Cummins QSC8.3-C230, 6-cylinder electronic turbocharged, charge air after cooled (air to air) diesel engine has 506 cu-in. (8.3 L) displacement, 4.49-in. (114 mm) bore x 5.31-in. (135 mm) stroke. Rated power 230-hp (172 kW) at 2200 rpm (all engine ratings are based on SAE standard ambient conditions). Maximum power of 250-hp (186 kW) at 2000 rpm. Peak torque is 800 ft-lbs. (1,085 N-m) at 1500 rpm. Emission certification: US EPA Tier III, Carb Tier III, EU Stage III.

Standard features are electronic diagnostic, maintenance monitor, fuel/water separator, engine/transmission protection system, fuel economy and reduced emissions.

Fuel tank capacity is 60 gallons (227 L).

Air Cleaner

The dry air cleaner has a safety element and restriction indicator.

Cooling System

The coolant-recovery cooling system has an extra large down flow radiator for maximum efficiency. The wide fin spacing reduces dirt build-up and provides optimum engine cooling.

Electrical, Instrumentation, and Accessories

The one-piece instrument panel flips down for easy servicing and is pre-wired to accommodate heavy-duty accessories. All wiring is color coded.

The unit has a 12-volt electrical system. Standard equipment includes a key-type anti-restart ignition system, 2 heavy-duty batteries, 100-amp alternator, mechanical pressure gauges, electrical temperature gauges, reset circuit breakers, lighted instruments, horn, work lights (two front, and two rear), key-switch actuated amber strobe light, forward alarm, reverse-actuated warning alarm and tilt steering.

Gauges include fuel level, ammeter, hourmeter, air pressure, engine oil pressure, engine coolant temperature, transmission oil pressure, and transmission oil temperature. Lights included are seat belt light, low air light, parking brake light, and step lights.

Transmission

The three-speed, fully reversing, modulated, powershift transmission has declutch and electric shift control. Brakes behind declutch. The filler pipe dipstick and large, heavy-duty, oil filter are easily accessible. Separate air-to-oil cooler. The integrally built torque converter has constant mesh gear sets actuated by hydraulic clutch packs. An automatic powershift control is standard.

Drive Axle

The heavy-duty planetary type drive axle housing is welded to the frame.

Steer Axle

The single hydraulic cylinder design steer axle, with heavy-duty links from the cylinder ram directly to tapered roller bearing mounted spindles, has tapered wheel and kingpin bearings. All joints are sealed, can be lubricated, and never need adjusting.

Brake System

The force cooled, wet disc, air/hydraulic actuated, service brakes are mounted on the drive axle. The transmission is equipped with a spring-applied drum brake for parking.

Chassis

The all welded frame has an integral, sloped, counterweight and tubular A-frame. A spring-assisted hood and hinged doors provide easy access to service points.

The overhead guard is integral with the operator station base. While the center mount operator station is standard, optional locations are available. The tinted, unbreakable, Lexan top with steel crossbars provides maximum visibility and protection. The suspension seat with an operator seatbelt is adjustable.

Power Steering

The hydrostatic steer-on-demand steering system provides excellent response at all engine speeds.

Hydraulic System

The large capacity hydraulic tank has a spin-on tank breather, suction strainers, return line filters and replaceable elements in the tank. The hydraulic system utilizes transmission-driven gear type pumps. The tank refill capacity is 72 gallons (273 L). The tilt lock valve prevents mast drift and reduces torsional stress. Dual lift cylinders have chrome-plated rods and self-adjusting packing. Control levers are conveniently located and the valves are controlled with hydraulic remotes.

Mast, Carriage, and Rollers

The 11-ft. (3.4 m) ULTRA-VU telescopic, nested-channel mast, with two multiple-leaf lift chains, is constructed of high-strength steel for minimal weight. The two lifting eyes and bolt-on caps permit safe, easy removal of the mast. The lift chains are located between the mast rails and are visible.

The “C” type carriage has a high strength-to-weight ratio. The forks are pin-mounted and fully adjustable from 120-in. (3,048 mm) outside to 2-in. (51 mm) inside the center brace.

Main rollers and chain rollers have shielded, tapered, roller bearings. The carriage side wear pads are adjustable to compensate for wear. All rollers can be lubricated.

Forks

The forks are forged from heat treated alloy steel.

Standard size:

5-in. x 12-in. x 96-in. (127 mm x 305 mm x 2438 mm).

This vehicle is certified to meet the applicable design and performance criteria required for Powered Industrial Trucks in OSHA Safety and Health Standards, Title 29 CFR, Part 1910.178, and the applicable design and performance requirements in ANSI B56.1 that were in effect at the time of manufacture. These standards also apply to the user and should be adhered to while operating this vehicle.

All specifications are subject to change without notice. Some operating data may be affected by the condition of the operating area. If these specifications are critical, contact the factory.