

# ETC MH 42

Articulated / Telescopic Insulated Material Handling



## Insulated versatility

The ETC MH 42 is a versatile insulated unit that is well suited to those customers in need of an aerial unit that can offer powerful capabilities. With an articulating and telescoping aerial lift that reaches a height of 42' to the bottom of the bucket, this unit has a standard option continuous rotation allowing for unrestricted rotation. This model also offers material handling capabilities with a hydraulic winch and a 5' jib that can lift up to 1,000 lbs.

**ETI**  
A PALFINGER Company

Equipment Technology LLC is a full service solution provider of the highest quality design, manufacturing, and post sale service.

Equipment Technology LLC  
 341 NW 122nd  
 Oklahoma City, OK 73114  
 Toll-Free: 1-888-748-3841  
 Fax: 1-405-755-6829  
 www.eti1.com

**ETC MH 42**

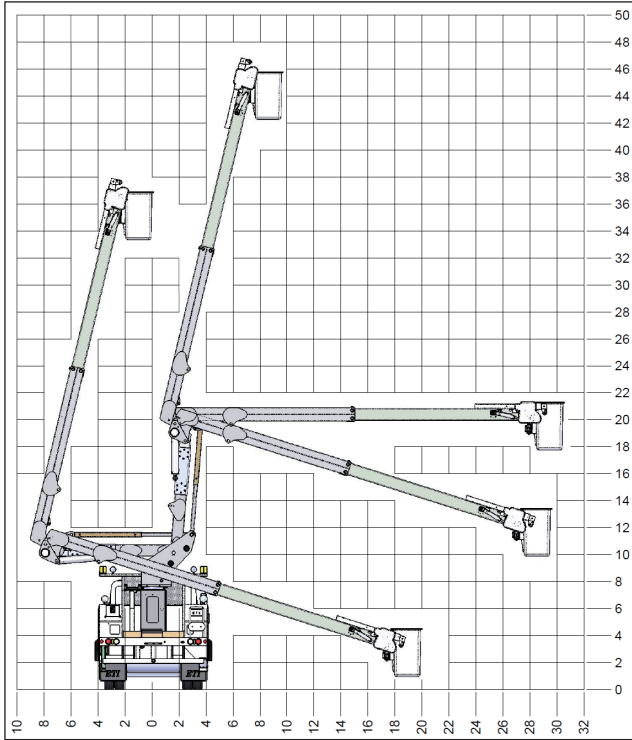

**General Specifications\***

Height to bottom of bucket	42 ft. - 0 in.
Working height	47 ft. - 0 in.
Side reach, End mount	30 ft. - 3 in.
Rotation	Continuous
Lower boom articulation	0 to 95 degrees
Upper boom travel	-17 to 76 degrees
Stow height	11 ft. - 4 in.
Rated bucket capacity	500 lbs.



**Options**

- Engine start/stop at bucket
- Emergency hydraulic power (12VDC)
- Hydraulic tool circuit
- Bucket liner
- Bucket cover
- Hydraulic Jib Extension

**Minimum Vehicle Specifications**

- GVWR 23, 500 lbs.
- C.A. 84 in.

**Standard Features**

- Fiberglass Inner Boom
- Hoses Inside Boom are contained in a cat track
- 18 gallon oil reservoir
- Lower Boom Insert
- Bucket with Center Step with bucket cover
- Outrigger/boom interlock
- Hydraulic Jib and Winch Package
  - 700 lbs. minimum capacity - up to 1,000 lbs maximum capacity
  - Hydraulic Tilting Jib Mounted on Side of Boom
  - Hydraulic Winch Mounted Under Jib
  - 60' x 1/2" winch line with swivel hook
  - Remote Winch Control at Lower Controls

