

MANISCOPIC

■ MT 1440



- Maximum lifting height: 13.53 m
- Capacity: 4000 kg
- Maximum forward reach: 9.38 m
- Hydraulic stabilizers
- Frame levelling: $\pm 9^\circ$
- Torque convertor

 **MANITOU**

MT 1440

 **Lifting capacity**4000 kg
 at 500 mm from forks heels.
 Tipping load at maximum reach
 with stabilizers1950 kg
 Tear out force with bucket
 to ISO 83138000 daN

 **Lifting height**13.53 m
Times: unladen / loaded (in s)
 Lifting15.5/15
 Lowering11.5/11.1
 Extension boom16.4/16.4
 Retraction boom11.9/11.8
 Crowd4
 Dump4

 **Tyres**400/80-24

 **Forks (mm)**
 Length1200
 Width x thickness125 x 50
 Maximum distance between forks1040
 Carriage rotation126°

 **Multidisc brakes - hydraulically assisted on both axles**

 **PERKINS Engine**
 Type1104D-44TA
 Capacity4 cylinders - 4400 cm³
 Power:
 (ISO/TR 14396)74.5 kW/101 HP at 2200 rpm
 Maximum torque400 Nm at 1400 rpm
 Direct injection
 Water cooling

 **Transmission**torque convertor
 Electro-hydraulic reversing shift
 4 speeds forward and reverse
 Maximum travel speed (kph)25

 **Hydraulics**
 Pumpgear type
 pressure/capacity270 bar/170 l/min

 **Capacities**
 Cooling system20 l.
 Engine oil10.9 l.
 Hydraulic oil175 l.
 Transmission oil23 l.
 Fuel tank140 l.

 **Weight unladen**11115 kg
Overall width2.35 m
Overall height2.45 m
Turning radius (outside wheels)3.98 m
Overall Length6.13 m
Ground clearance0.38 m
Drawbar pull8250 daN

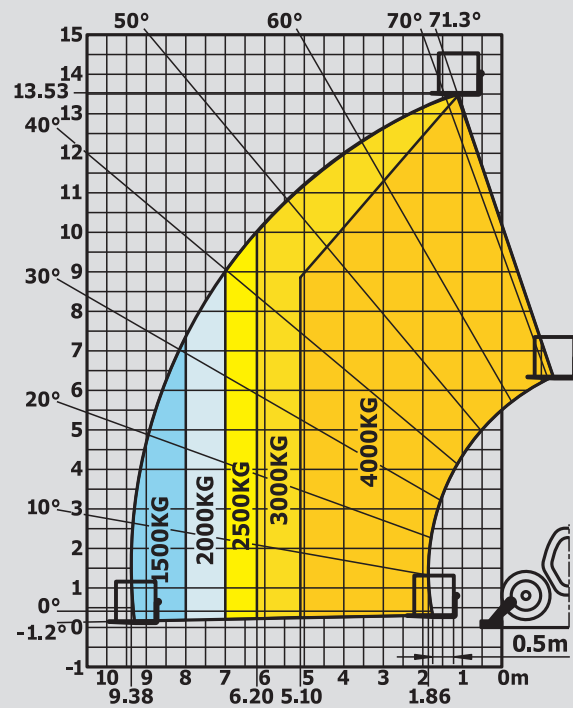

Under
 EN 1459
 annexe B

A	1200
B	3070
C	1905
C1	1790
D	6135
D1	6020
D2	4872
E	7335
F	1960
F1	1960
G	384
G1	367
G2	380
G3	355
H	9°
H1	9°
I	1160
J	892
K	1040
L	50
N	1855
O	125
P2	34
P3	33
R	3779
S	8615
T	4183
U1	2452
U2	2640
V	5468
V1	1285
V2	3975
W	2351
W1	3793
W2	1134
W3	2422
Y	12
Z	114

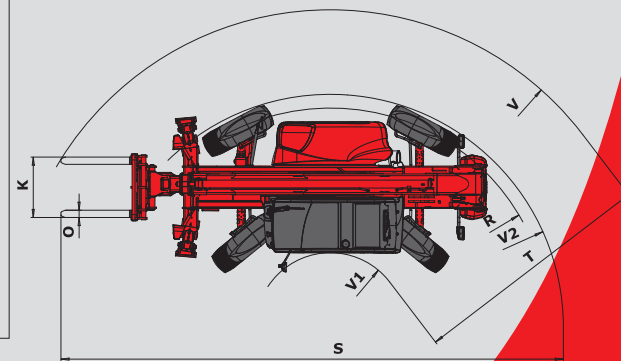
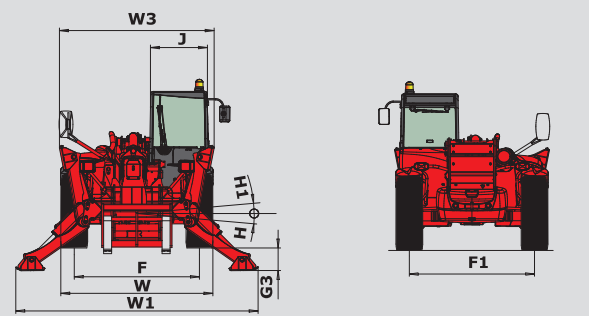
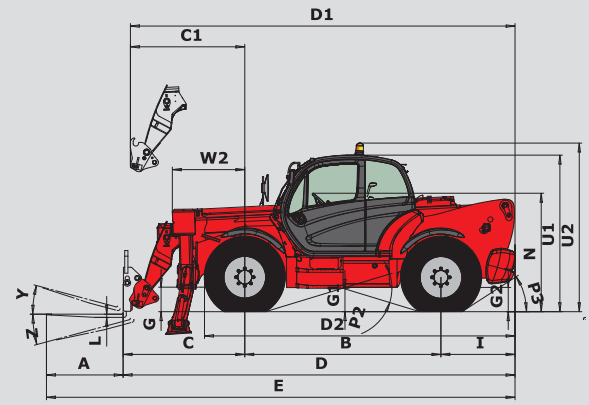

The specifications contained herein shall not bind the manufacturer and are subject to change without notice.
 This equipment described in this leaflet may be standard, optional, or unavailable, depending on the versions.
 For more details, contact your MANITOU dealer.

MANITOU BF SA
 B.P. 249 - 44158 Ancenis Cedex - France
 Tel. : 33 2 40 09 10 11 / Export Department Fax : 33 2 40 09 10 97
 www.manitou.com

