

Manitowoc 21000

Product Guide



Features

- 907 t (1,000 USt) capacity with MAX-ER®
- 756 t (834 USt) capacity
- 5 381 m-ton (38,920 ft-kips) maximum load moment
- 109,7 m (360 ft) heavy-lift boom
- 121,9 m (400 ft) long-reach boom
- 195,1 m (640 ft) luffing jib on heavy-lift boom



Features

EPIC®

Manitowoc's field-proven Electronically Processed Independent Controls (EPIC) system delivers high productivity and precise load control by instantly matching an operator's commands to the crane function. EPIC's microprocessor maximizes a Manitowoc crane's function capability and simplifies servicing by pinpointing any problem in the crane's engine, power transmission and other operating systems. In addition, EPIC increases versatility by easily tailoring a Manitowoc crane's operation for specialized applications, with or without attachments. EPIC is a key reason no other crane can match the performance and reliability of Manitowoc.



FACT™ Connectors

Manitowoc's patented Fast Aligning Connection Technology (FACT) automatically aligns crane components for fast, easy assembly with increased safety.

Hydraulics

Our closed-loop system provides a separate hydraulic circuit to power each crane function and increase productivity. The result is truly independent variable-speed operation of the swing, load hoist, boom hoist and travel functions.

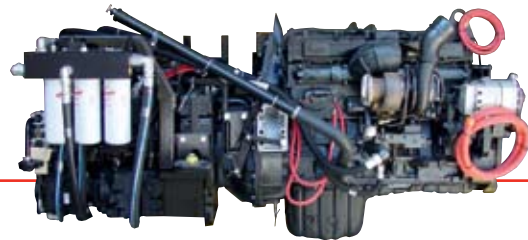

Octa-trac®

The 21000 uses Manitowoc's patented Octa-trac eight-crawler travel system. With Octa-trac, the left- and right-side crawlers each consist of two dual-crawler modules mounted at the ends of a connecting beam for improved transportation and ground bearing.



Contents

Specifications	5
Outline dimensions	10
Transport data	17
Crane assembly	18
Performance data	20
Boom combinations	23
Main boom range diagram / load charts	25
Long-reach boom range diagram / load charts	27
MAX-ER® outline dimensions	29
MAX-ER® performance data	32
MAX-ER® boom combinations	34
MAX-ER® range diagrams / load charts	36
Manitowoc Crane Care	42

Notes

Specifications

Upperworks



Engine

Cummins Model QSK19-C600 diesel, 6 cylinder, 450 kW (600 BHP) @ 2000 governed RPM.

Multiple hydraulic pump drive transmission provides independent power for all machine functions.

Two 12 volt maintenance-free, Group 8D batteries, 1155 CCA at -18°C (0° F), 24 volt starting and 120 amp alternator.

One 927 l (245 gal) capacity diesel fuel tank, mounted in rear of upperworks, with level indicator in operator's cab.

➤ Optional: Cold-weather package with heater for fluids, brake pedals, batteries, and computer display.



Controls

Modulating electronic-over-hydraulic controls provide infinite speed response directly proportional to control lever movement. Controls include Manitowoc's exclusive EPIC® Electronically Processed Independent Control system providing microprocessor driven control logic, pump control, on-board diagnostics, and service information.

Block-up limit control is standard for hoist and auxiliary lines.

Integrated Rated Capacity Limiter system (RCL) is standard for main boom. "Function cut-out" or "warning only" operation is selected via a keyed switch on the RCL console. Includes travel and swing alarms.

➤ Optional: Upper boom point assembly with RCL.

➤ Optional: Anemometer (wind indicator).



Hydraulic system

Twelve high-pressure piston pumps, driven by a multi-pump transmission, provide independent closed-loop hydraulic power for the hoisting drums, mast hoist, boom hoist, swing, and crawlers.

A gear pump provides power for jacks, pin pullers, and other accessories.

Hydraulic reservoir has 719 l (190 gal) capacity and is equipped with breather, cleanout access, filters, and internal diffuser.

Each function is equipped with relief valves to protect the hydraulic circuit from overload or shock.

System includes oil cooler and replaceable spin-on and full flow filters. All oil is filtered twice: at the reservoir and before entering the hydraulic pumps.

System	Pumps	kg/cm ² (psi)	lpm (gpm)
Front hoist drum			
Rear hoist drums*	2	422 (6,000)	379 (100)
Boom hoist	2	422 (6,000)	303 (80)
Swing	2	422 (6,000)	303 (80)
Left crawlers (also diverts for luffing drum)	2	422 (6,000)	303 (80)
Right crawlers (also diverts for mast hoist)	2	422 (6,000)	303 (80)
Accessory system	1	211 (3,000)	95 (25)
Optional MAX-ER jacking	1	211 (3,000)	246 (65)

*Also powers optional boom-butt-mounted hoist drum.



Drums

Basic crane is equipped with front and rear hoist drums, each 1 780 mm (65-1/2") wide, 660 mm (26") diameter, and grooved for 32 mm wire rope.

Front drum is mounted on front section of rotating bed. Rear drum is mounted on rear section. Each end of each drum is driven by a variable-displacement hydraulic motor and a planetary reduction gear box equipped with bi-directional brake.

Drum rotation indicator is standard for each drum.

Hoists include 32 mm wire rope.

➤ Optional: Hydraulically powered auxiliary drum mounted in boom butt. Uses 1-1/8" wire rope with a line pull of 144 kN (32,300 lb).

➤ Optional: Hydraulically powered auxiliary/luffing drum mounted on rear section of rotating bed. Same dimensions and specifications as main hoisting drums.

Specifications



Mast hoist

Dual-drum mast hoist mounted in rear section of rotating bed is powered by a variable-displacement hydraulic motor and a planetary reduction gear box with internal brake. Ratcheting pawl standard. Includes mast-hoist wire rope. Each drum equipped with lagging 508 mm (20") wide and 584 mm (23") diameter.



Boom hoist

Independent boom hoist, mounted in mast butt, has grooved drum 1 397 mm (55") wide and 787 mm (31") diameter.

Drum is powered by two variable-displacement hydraulic motors coupled to integral brakes and planetary reduction gearboxes. Ratcheting pawl, rotation indicator, pressure roller, and wire rope for reeving 20-part boom hoist line are standard.



Swing system

High strength fabricated steel alloy rotating bed is mounted on 3,40 m (11' 2") diameter triple-row roller bearing.

The rotating bed is composed of front and rear sections joined with FACT™ alignment, four power-actuated pins, and H-FACT® hydraulic quick coupler system. The front section is equipped with a hoist drum and the power plant. The rear section includes a second hoist drum, gantry, and mast hoist.

Independent swing is powered by two swing drives, each composed of a fixed-displacement hydraulic motor coupled to a planetary reduction gearbox with internal brake. 360° positive swing lock is standard.

Swing system maximum speed: 1.0 rpm.



Boom support system

Gantry

The 8,5 m (28') long retractable gantry provides the geometry to raise the stationary mast. Gantry top is connected to mast-hoist equalizer by 12-part reeving. Equalizer is connected to mast top by high-strength steel straps. The gantry's telescoping backhitch is equipped with power actuated locking pins.

Mast

Stationary No. 81 lattice mast provides geometry to raise and support all boom lengths. 30,5 m (100') mast standard for basic crane; 42,7 m (140') mast required for MAX-ER® applications. Boom-hoist rope reeved from drum in mast butt through sheaves in mast top and boom-hoist equalizer forms 20-part boom-hoist rigging. High-strength steel straps connect equalizer to boom top.

Cushioned boom stop and automatic boom stop are standard.



Counterweight

		kg	lb	kg	lb
Upperworks					
1	Tray	11 657	25,700	11 657	25,700
28	Box	8 165	18,000	228 620	504,000
2	Railing	34	75	68	150
1	Platform	272	600	272	600
—	Pins & Hardware	103	250	103	250
Upperworks TOTAL				240 720	530,700
Upperworks					
2	Inner Box	24 268	53,500	48 536	107,000
2	Outer Box	21 092	46,500	42,184	93,000
Upperworks TOTAL				90 720	200,000
TOTAL				331 440	730,700



Operator's cab

Fully enclosed and insulated steel module is mounted at left front corner of rotating bed on a pivoting frame that permits cab to be repositioned for transportation or tilted for increased upward visibility.

Module is equipped with sliding door, large safety glass windows on all sides and roof. Signal horn, cab space heater, front and roof windshield wipers, dome light, sun visor and shade, fire extinguisher, air circulating fan, and air conditioning are standard.

➤ Optional: Nylon protective window covers.

Attachments



No. 80 Heavy-lift boom

The liftcrane is equipped with No. 80 heavy-lift boom. 30,5 m (100') minimum length consists of a 9,1 m (30') butt, 12,2 m (40') insert, 6,1 m (20') transition insert, and 3,0 m (10') top with fifteen 762 mm (30") diameter roller bearing sheaves for 544-metric-ton (600-ton) maximum capacity. Rating can be increased

Specifications

to 756 metric-tons (831 tons) with optional boom point. Includes rope guides and boom angle indicator. Boom also includes 6,1 m (20') and 12,2 m (40') inserts to increase boom length to 109,7 m (360').

The No. 80 boom uses steel suspension straps and Manitowoc's patented, exclusive FACT™ connection system consisting of two vertical pins, two horizontal connection pins, and alignment pads for each boom connection location.

Liftcrane attachment includes 32 mm rotation resistant wire rope for two load lines, each 1 676 m (5,500').

Luffing jib preparation is standard.

Includes 544-metric-ton (600-ton) load block with duplex hook.

➤ Optional: Detachable upper boom point with one 762 mm (30") diameter tapered roller bearing steel sheave with rope guard.

➤ Optional: Two stabilizers to permit 360° swing when crawlers are in narrow configuration. Each fabricated steel stabilizer includes hydraulic leveling jack and a support pad. One stabilizer is mounted to each crawler beam. Stabilizers are controlled individually from hydraulic controls mounted to the stabilizer frame.



No. 80-81 Long-reach boom

➤ Optional: No. 81 boom inserts and top. Used with components of No. 80 boom to form No. 80-81 long-reach boom. Minimum boom length, 54,9 m (180'); maximum length, 121,9 m (400'). Intermediate suspension required for No. 80-81 boom lengths of 103,6 m (340') or more.

No. 80-81 boom starts with components of No. 80 boom, finishes with components of No. 81 boom.

No. 81 components include: 6,1 m (20') and 12,2 m (40') straight inserts; 6,1 m (20') tapered insert (for transition from No. 80 to No. 81 boom); 6,1 m (20') straight transition insert for transition from pin-type FACT™ connectors on tapered insert to hook-type FACT™ connectors on No. 81 inserts; 9,1 m (30') No. 81 boom top; steel rigging straps; wire rope guide; and RCL hardware.



No. 81 Luffing jib

➤ Optional: 91,4 m (300') No. 81 luffing jib, for use on No. 80 boom, either with basic Model 21000 or with MAX-ER attachment.

No. 81 luffing jib uses inserts, top, and rigging components from No. 81 boom. Luffing jib butt is used only in luffing jib.

Luffing jib attachment includes 23,0 m (75' 5") No. 481 main strut with 11 sheaves, 24,6 m (80' 8") No. 481 jib strut with 11 sheaves, main-strut backstay straps, jib-support straps, 32 mm diameter wire rope for 22-part reeving between the struts, and RCL hardware.

➤ Optional: Third drum on rear section of rotating bed is used for luffing.

Minimum length, 36,6 m (120'); maximum length, 91,4 m (300').

Luffing jib attachment includes dolly to support jib point during jackknife erection and lowering.

Uses same upper boom point as No. 80 or No. 80-81 boom.



MAX-ER®

The MAX-ER® attachment boosts the 21000's maximum capacity to 907 metric tons (1,000 tons).

Its components include:

One 12,2 m (40') No. 81 insert, added to increase mast length to 42,7 m (140').

Two additional swing drives (for a total of four) mounted on the rotating module. Each swing drive is powered by a fixed-displacement hydraulic motor coupled to a planetary reduction gearbox and internal brake.

A wheeled or hanging MAX-ER counterweight assembly attached to the top of the mast by steel straps and to the rear of the upperworks by shear-frame inserts.

The hanging MAX-ER counterweight is 17,9 m (58' 9") or 22,1 m (72' 6") behind the crane's centerline of rotation, and the wheeled MAX-ER counterweight

Specifications

is 18,0 m (59' 0") or 22,0 m (72' 0") behind the crane's centerline of rotation.

The wheeled counterweight uses large off-road tires, which can be positioned for traveling, crabbing, or swinging.

It also includes hydraulic support jacks and pads.

Wheeled counterweight assembly

Item	Qty.	Unit weight		Total weight	
		kg	lb	kg	lb
Base/wheel assembly	1	42 524	93,750	42 524	93,750
Catwalk	1	726	1,600	726	1,600
Cylinder support (Sub assembly)	4	126	277	504	1,108
Hydraulic cylinder	2	1 950	4,300	3 900	8,600
A-Frame	2	3 495	7,705	6 990	15,410
Counterweight					
Side box	18	19 958	44,000	395 245	792,000
Center box	4	19 958	44,000	79 832	176,000
Tray	1	15 381	33,910	15 381	33,910
Miscellaneous				736	1,622
				509 840	1,124,000

Hanging counterweight assembly

Item	Qty.	Unit weight		Total weight	
		kg	lb	kg	lb
Sub plate for counterweight tray	2	2 404	5,300	4 808	10,600
Cylinder support (Sub Assembly)	4	126	277	504	1,108
Hydraulic cylinder	2	1 950	4,300	3 900	8,600
A-Frame	2	3 495	7,705	6 990	15,410
Counterweight					
Side box	20	19 958	44,000	399 160	880,000
Center box	4	19 958	44,000	79 832	176,000
Tray	1	15 381	33,910	15 381	33,910
Miscellaneous				755	1,672
				511 330	1,127,300

A 544-mton (600-ton) load block with duplex hook.

➤ Optional: 907-mton (1,000-ton) capacity duplex hook with roller thrust bearing and heavy-duty positive locking bar latches. Hook is used with the basic crane's 544-mton (600-ton) load block and the MAX-ER's standard 544-mton (600-ton) load block to provide 907-mton (1,000-ton) capacity.

➤ Optional: Additional fifteen sheaves in No. 80 boom point. Required for 907-mton (1,000-ton) capacity.

Lowerworks

Carbody

Connects rotating bed and crawler assemblies. Fabricated steel rotating module is mounted to carbody module by 3,4 m (11' 2") diameter triple-row roller bearing.

Module is equipped with FACT connectors and powered pins.

For 9,1 m (30') "narrow" stance, crawler beams attach directly to carbody module.

For standard 14,5 m (47' 6") "wide" stance, two transverse carbody beams mount to the carbody module, and the crawler beams are then mounted to the transverse beams.

Crawlers

The 21000 uses Manitowoc's patented Octa-trac® eight-crawler travel system.

With Octa-trac, the left- and right-side crawlers each consist of two dual-crawler modules mounted at the ends of a connecting beam. The overall assembly measures 14,0 m (46' 0") long.

Each of Octa-trac's four dual-crawler modules has two parallel treads, each 4,95 m (16' 3") long and 1,22 m (4' 0") wide. Together, the two treads give each crawler module an overall width of 3,5 m (11' 6").

All eight treads are powered hydraulically, with the four right-side treads operating in unison, and the four left-side treads operating in unison.

Crawlers permit travel and counter-rotation with full rated load. Maximum travel speed, 1,1 kph (0.7 mph).

Crane assembly equipment

Portable engine-powered hydraulic unit to engage and disengage hydraulic connecting pins in the lowerworks; extend and retract the crawler beam hydraulic jacks; and extend and retract the boom cylinders. Various lifting slings and shackles, and counterweight tray handling pendants.

Specifications

Optional equipment

Optional: Blocks and Hooks, each with 762 mm (30") roller-bearing sheaves for 32 mm wire rope, a roller-bearing swivel hook, a hook latch, and a swivel lock.

23-mton (25-ton) swivel hook and weight ball

907-mton (1,000-ton) duplex hook assembly with roller thrust bearing, and heavy-duty positive locking bar latches. Can be used with one 544-mton (600-ton) block for up to 544-mton (600-ton) rating, or with two 544-mton (600-ton) blocks for higher capacities.

Optional: Wire rope for various applications.

Optional: Equipment and testing for special code compliance.

Optional: Hydraulic Test Kit: required to properly analyze the performance of the EPIC® control system.

Optional: Service Interval Kits: for the regularly scheduled maintenance of general crane operations.

Optional: Lighting Packages: consult dealer for available options.

Optional: Special paint colors other than Manitowoc standard red and black.

Optional: Custom vinyl decals of customer name and/or logo from artwork supplied by customer.

Optional: Export Packaging: basic crane, boom and jibsections. MAX-ER® export packaging available.

Outline dimensions

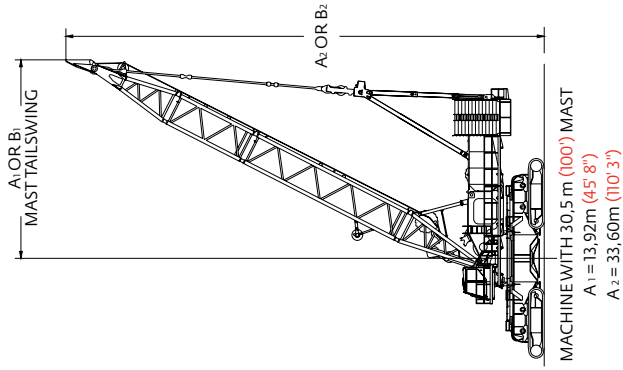

MACHINE WITH 42.7 m (140') MAST
B₁ = 19.46m (63' 10")
B₂ = 44.47m (145' 11")

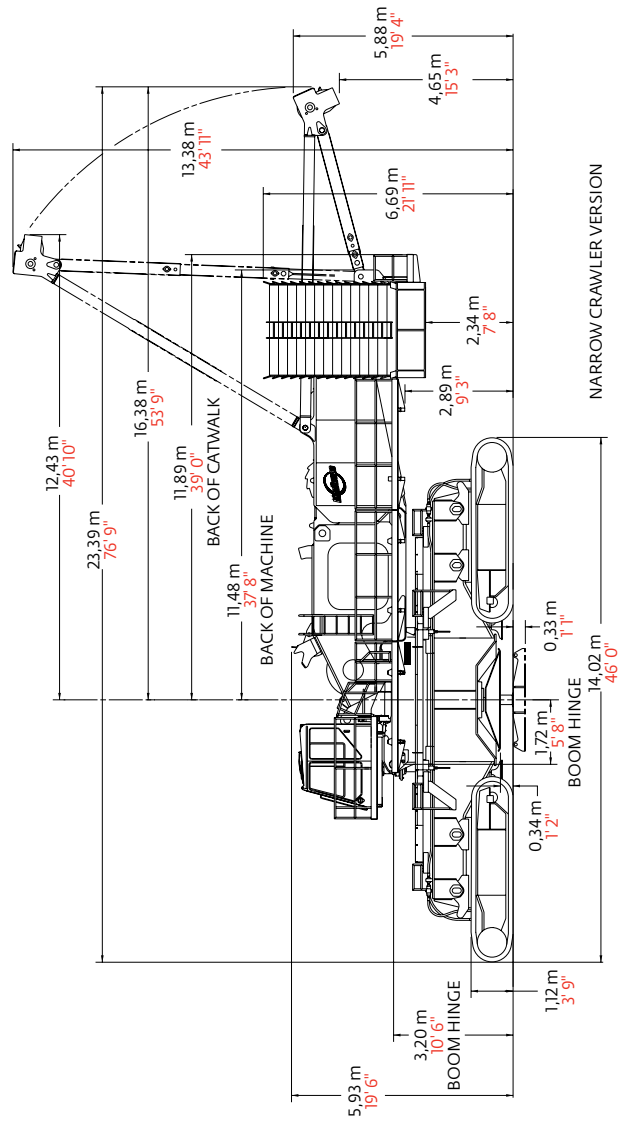
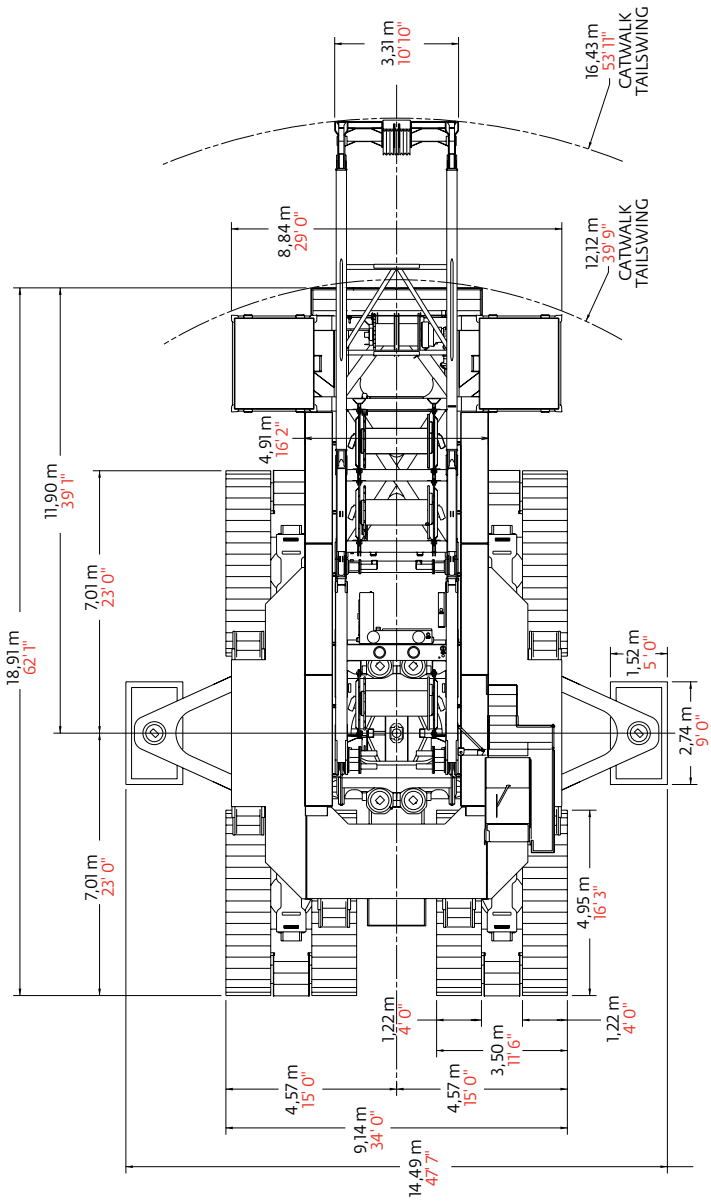
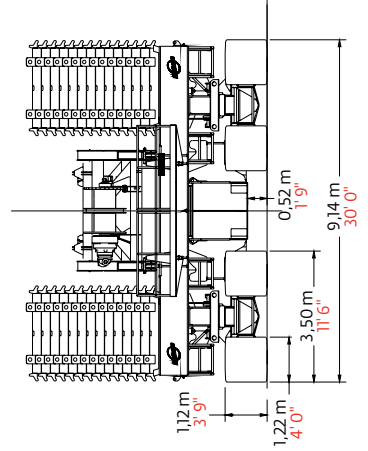

Outline dimensions

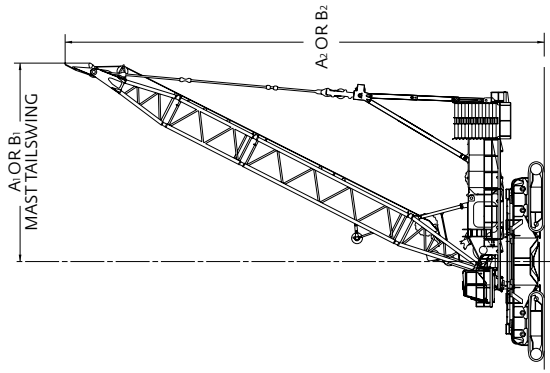

MACHINE WITH 30.5 m (100') MAST
 A₁ = 13.92 m (45' 8")
 A₂ = 33.60 m (110' 3")

MACHINE WITH 42.7 m (140') MAST
 B₁ = 19.46 m (63' 10")
 B₂ = 44.47 m (145' 11")

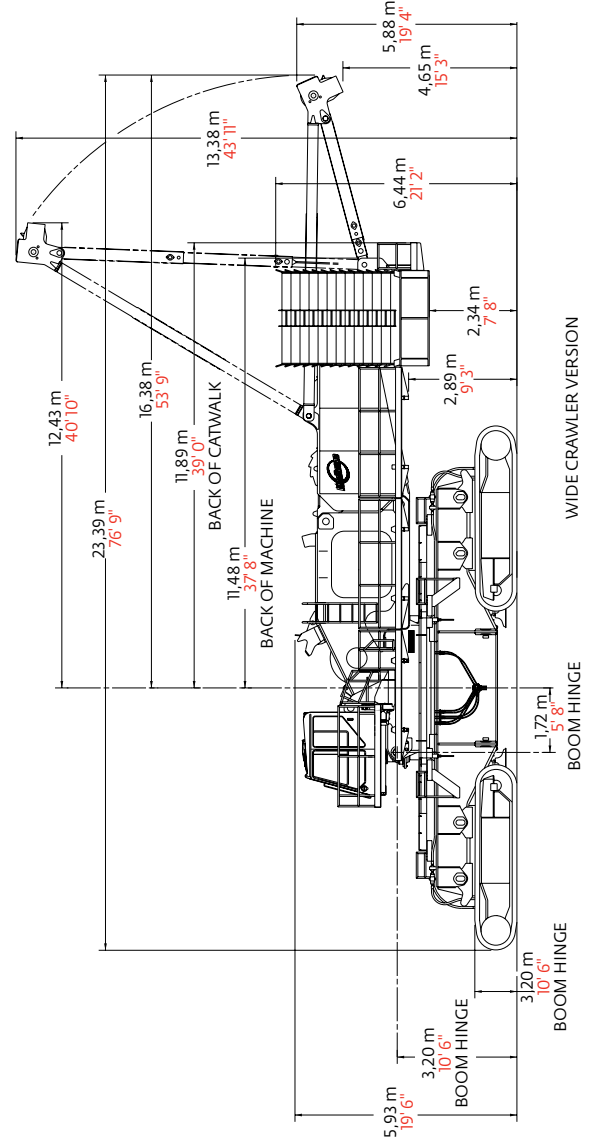
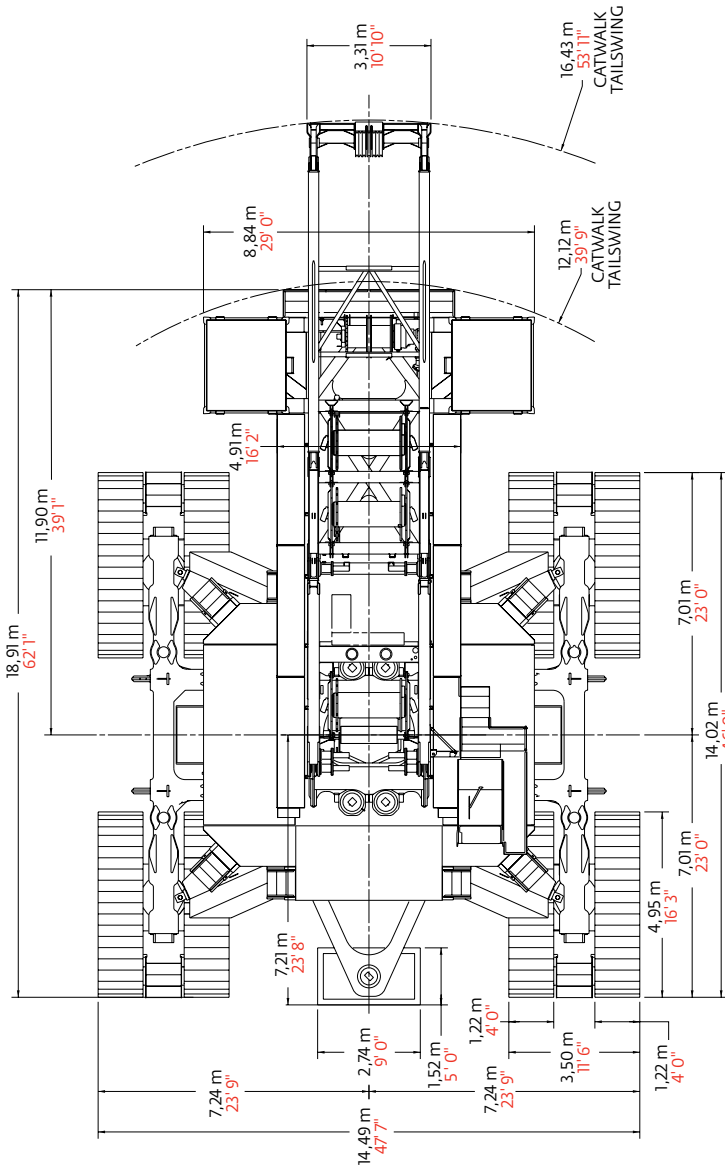
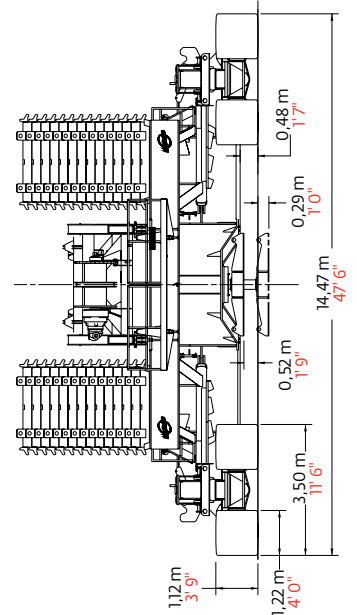

Outline dimensions

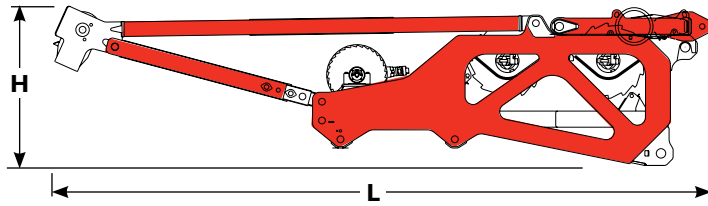

Rotating bed - rear section x 1

Length	12,15 m	39' 11"
Width	3,31 m	10' 11"
Height	2,84 m	9' 4"
Weight	36 139 kg	79,675 lb

Note: Weight includes rotating bed rear section, gantry, mast hoist with wire rope, equalizer, second hoist drum with wire rope and optional luffing/auxiliary third hoist drum with wire rope.

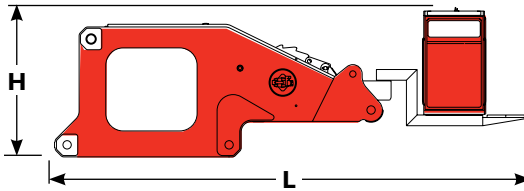

Rotating bed - front section and cab x 1

Length	8,95 m	29' 5"
Width	3,40 m	11' 2"
Height	2,51 m	8' 3"
Weight	42 984 kg	94,765 lb

Note: Weight includes rotating bed front section, first hoist drum with wire rope, diesel powerplant, operator's cab, full hydraulic fluid reservoir, and half tank of fuel.

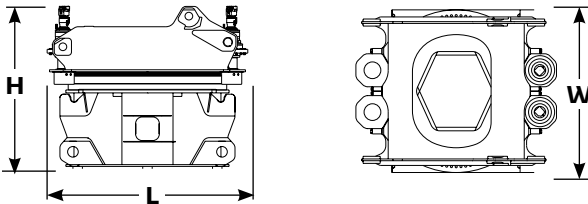

Carbody with rotating module and two swing drives x 1

Length	4,31 m	14' 2"
Width	3,51 m	11' 6"
Height	4,11 m	13' 6"
Weight	42 456 kg	93,600 lb

Note: Two additional swing drives required for MAX-ER. Total additional weight for both is 1 678 kg (3,700 lb).

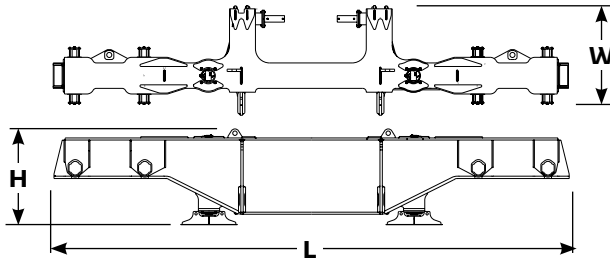

Crawler beam x 2

Length	11,12 m	36' 6"
Width	2,35 m	7' 9"
Height	2,04 m	6' 9"
Weight	23 736 kg	52,330 lb

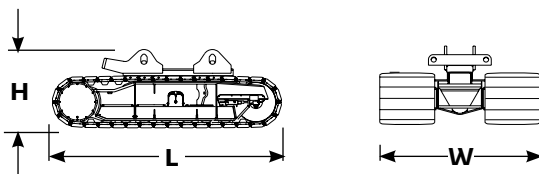

Crawlers x 4

Length	4,97 m	16' 4"
Width	3,50 m	11' 6"
Height	1,71 m	5' 8"
Weight	32 622 kg	71,920 lb

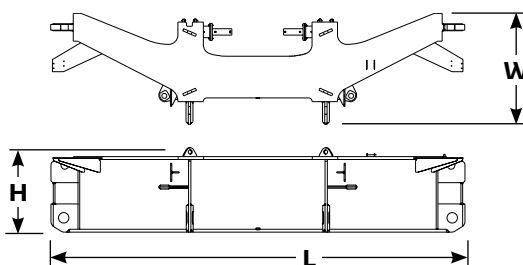

Wide-stance carbody beam and struts x 2

Length	9,11 m	29' 11"
Width	2,44 m	8' 0"
Height	1,86 m	6' 1"
Weight	22 897 kg	50,480 lb

Option

Outline dimensions

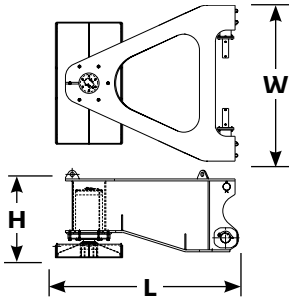

Outriggers and jacks, pads		x 2
Length	4,15 m	13' 8"
Width	3,51 m	11' 6"
Height	1,97 m	6' 6"
Weight	12 305 kg	27,130 lb

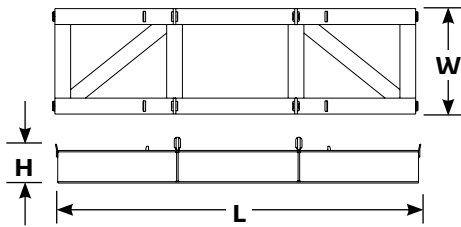

Counterweight tray		x 1
Length	8,79 m	28' 10"
Width	2,54 m	8' 4"
Height	1,14 m	3' 9"
Weight	11 657 kg	25,700 lb

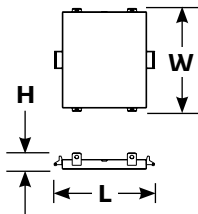

Side counterweight		x 28
Length	2,55 m	8' 5"
Width	2,61 m	8' 7"
Height	0,41 m	1' 4"
Weight	8 164 kg	18,000 lb

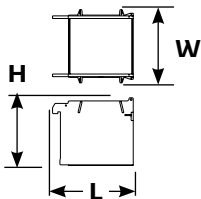

Carbody - inner counterweight		x 2
Length	1,95 m	6' 5"
Width	1,77 m	5' 10"
Height	1,65 m	5' 5"
Weight	24 267 kg	53,500 lb

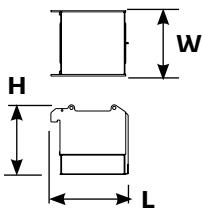

Carbody - outer counterweight		x 2
Length	1,84 m	6' 1"
Width	1,56 m	5' 2"
Height	1,66 m	5' 6"
Weight	21 092 kg	46,500 lb

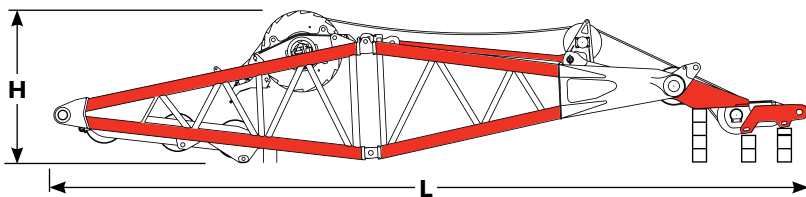

No. 81 Mast top, butt, boom hoist drum, wire rope guides, supports and straps, No. 80 Boom equalizer		x 1
Length	15,01 m	49' 3"
Width	2,41 m	7' 11"
Height	3,06 m	10' 1"
Weight	36 786 kg	81,100 lb

Note: Includes standard amount of wire rope.

Option

Outline dimensions

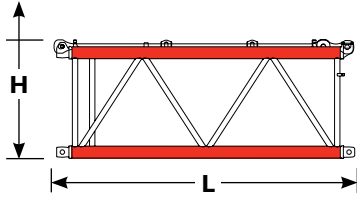

No. 81 6,1 m (20') Mast insert and straps		
		x 1
Length	6,35 m	20' 10"
Width	3,38 m	11' 1"
Height	2,50 m	8' 3"
Weight	3 771 kg	8,315 lb

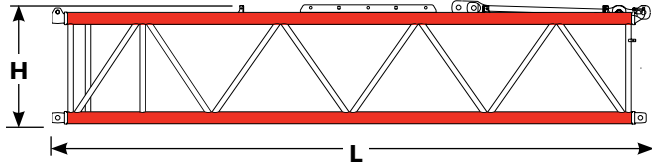

No. 81 12,2 m (40') Mast insert, mast equalizer and straps		
		x 1
Length	12,45 m	40' 10"
Width	3,38 m	11' 1"
Height	2,50 m	8' 3"
Weight	7 565 kg	16,680 lb

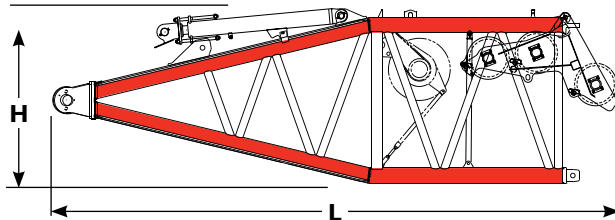

No. 80 Boom butt, 9,1 m (30') Boom stop, wire rope guides		
		x 1
Length	10,19 m	33' 5"
Width	3,96 m	13' 0"
Height	3,14 m	10' 4"
Weight	15 778 kg	34,785 lb

Note: Optional auxiliary drum shown.

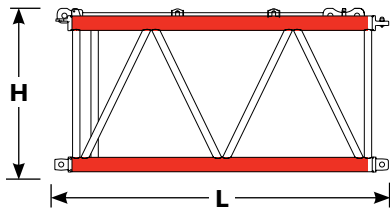

No. 80 6,1 m (20') Boom insert and straps		
		x 1, 2
Length	6,34 m	20' 10"
Width	3,96 m	13' 0"
Height	3,14 m	10' 4"
Weight	7 474 kg	16,480 lb

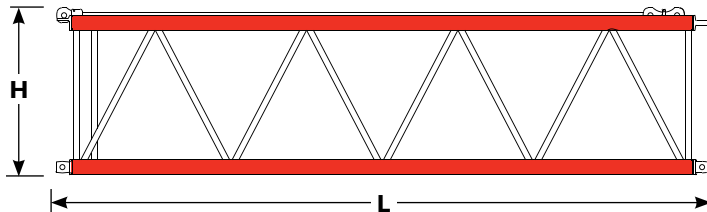

No. 80 12,2 m (40') Boom insert and straps		
		x 1, 2, 3, 4, 5, 6
Length	12,45 m	40' 10"
Width	3,96 m	13' 0"
Height	3,14 m	10' 4"
Weight	11 341 kg	25,005 lb

Note: For 12,2 m (40') insert with equalizer rail, add 719 kg (1,585 lb) and 178 mm (0' 7") in height.

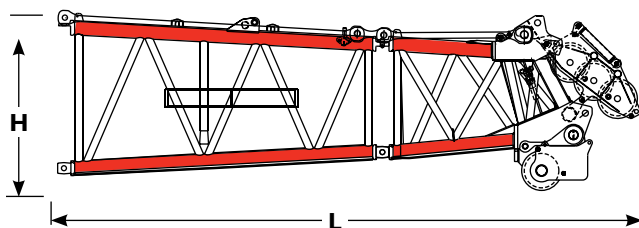

No. 80 Tapered insert 6,1 m (20'), boom top 3,0 m (10'), wire rope guide and straps		
		x 1
Length	11,18 m	36' 8"
Width	3,96 m	13' 0"
Height	3,14 m	10' 4"
Weight	25 945 kg	57,200 lb

Option

Outline dimensions

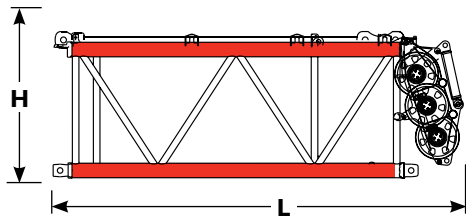

No. 81 Transition insert 6,1 m (20')	wire rope guide and straps		x 1
Length	7,11 m	23' 4"	
Width	3,96 m	13' 0"	
Height	3,14 m	10' 4"	
Weight	6 576 kg	14,501 lb	

Note: Shown with wire rope guides from No. 80 Boom top in stowed position.

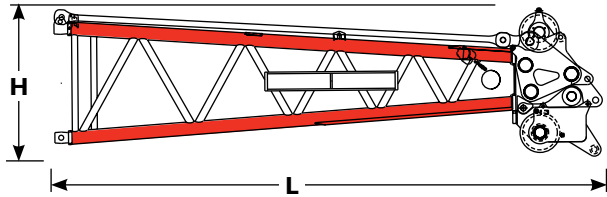

No. 81 Boom top 9,1 m (30')	wire rope guide and straps		x 1
Length	10,46 m	34' 4"	
Width	3,38 m	11' 1"	
Height	2,50 m	8' 3"	
Weight	5 112 kg	33,320 lb	

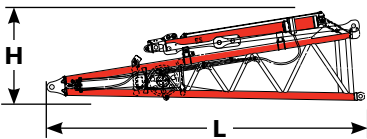

No. 81 Luffing jib - main strut, butt, wire rope guides, stops and straps			x 1
Length	7,75 m	25' 5"	
Width	3,42 m	11' 3"	
Height	2,30 m	7' 7"	
Weight	7 263 kg	16,013 lb	

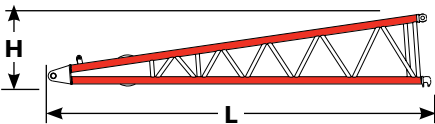

No. 81 Luffing jib - jib strut, butt and wire rope guides			x 1
Length	9,35 m	30' 9"	
Width	3,17 m	10' 5"	
Height	1,77 m	5' 10"	
Weight	4 707 kg	10,376 lb	

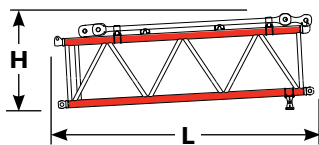

No. 81 Luffing jib - 6,1 m (20')	main strut insert and straps		x 1
Length	6,28 m	20' 8"	
Width	2,44 m	8' 0"	
Height	3,14 m	10' 4"	
Weight	3 208 kg	7,704 lb	

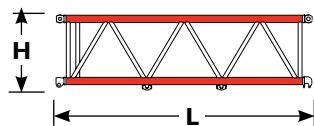

No. 81 Luffing jib - 6,1 m (20')	jib strut insert		x 1
Length	6,28 m	20' 8"	
Width	2,44 m	8' 0"	
Height	1,85 m	6' 1"	
Weight	2 184 kg	4,814 lb	

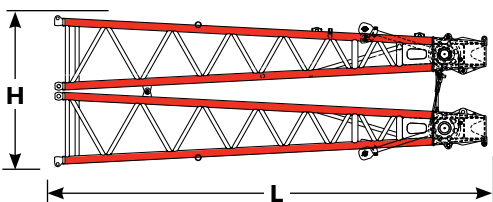

No. 81 Luffing jib - main strut top and jib strut top			x 1
Length	10,24 m	33' 7"	
Width	2,44 m	8' 0"	
Height	3,63 m	11' 11"	
Weight	9 931 kg	21,894 lb	

Note: Shown in standard shipping configuration

Option

Outline dimensions

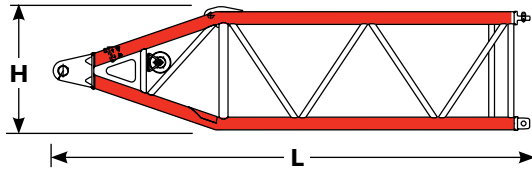

No. 81 Luffing jib butt 9,1 m (30') and wire rope guide			x1
Length	9,40 m	30'10"	
Width	1,78 m	5'11"	
Height	0,82 m	2'8"	
Weight	7 699 kg	16,975 lb	

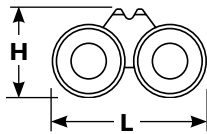

No. 81 Luffing jib dolly			x1
Length	2,88 m	9'6"	
Width	2,37 m	7'10"	
Height	1,60 m	5'3"	
Weight	3 057 kg	6,740 lb	

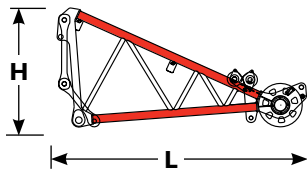

Upper boom point 4,6 m (15') wire rope guide and straps			x1
Length	4,26 m	14'0"	
Width	1,17 m	3'10"	
Height	2,21 m	7'3"	
Weight	1 360 kg	3,000 lb	

Note: Can be on No. 80 or No. 81 Boom.

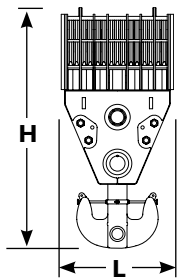

544-mton (600-ton) block with 544-mton (600-ton) hook			x1
Length	1,68 m	5'10"	
Width	1,26 m	4'2"	
Height	2,51 m	12'7"	
Weight	16 828 kg	37,100 lb	

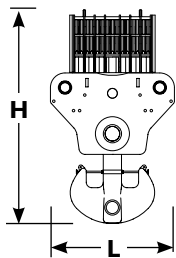

544-mton (600-ton) block with 907-mton (1,000-ton) hook			x1
Length	1,76 m	8'6"	
Width	1,26 m	3'9"	
Height	3,04 m	14'8"	
Weight	21 318 kg	47,000 lb	

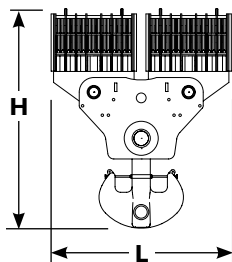

907-mton (1,000-ton) block with 907-mton (1,000-ton) hook			x1
Length	2,59 m	12'5"	
Width	1,15 m	3'10"	
Height	3,13 m	15'0"	
Weight	31 751 kg	70,000 lb	

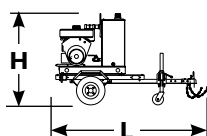

Portable hydraulic power unit			x1
Length	1,95 m	6'1"	
Width	1,4 m	4'5"	
Height	1,3 m	4'2"	
Weight	839 kg	1,850 lb	

▶ Option

Transport data

Trailer load out summary

Item	Model 21000 narrow configuration No. 80 Boom 109,7 m (360') and No. 81 Mast 30,5 m (100')																				
	Weight each item	Quantity on trailer load #																			
	kg (lb)	1	2-3	4-7	8	9	10-11	12-13	14	15	16	17	18-26	27	28-30	31	32-35	36	37	38	
Carbody, slewing adapter frame, swingers	42 456 (93,600)	1																			
Crawler beam	23 736 (52,330)		1																		
Crawler assembly	32 622 (71,920)			1																	
Rotating bed front and cab	42 984 (94,765)				1																
Rotating bed rear	36 139 (79,675)					1															
Carbody inner counterweight	24 267 (53,500)						1														
Carbody outer counterweight	21 092 (46,500)							1													
Counterweight tray and catwalk	11 657 (25,700)								1												
Side counterweight box	8 164 (18,000)									1	1			1	1	1					
No. 81 Mast top and butt, equalizer, guides	36 786 (81,100)									1											
6,1 m (20') No. 81 Mast insert and straps	3 771 (8,315)										1										
12,2 m (40') No. 81 Mast insert and straps	7 565 (16,680)											1									
9,1 m (30') No. 80 Boom butt, stop & guides	15 778 (34,785)													1							
6,1 m (20') No. 80 Boom insert and straps	7 474 (16,480)															1					
12,2 m (40') No. 80 Boom insert and straps	11 341 (25,005)														1		1				
6,1 m (20') No. 80 Transition insert and 3,0 m (10') top	25 945 (57,200)																	1			
544-mton (600-ton) hook block	16 828 (37,100)																			1	
Miscellaneous*									1		1	1				1				1	1
Approximate total shipping weight each trailer load kg (lb)		42 456 (93,600)	23 736 (52,330)	36 622 (71,920)	42 984 (94,765)	36 139 (79,675)	24 267 (53,500)	21 092 (46,500)	11 657 (25,700)	36 786 (81,100)	11 935 (26,315)	15 729 (34,680)	16 328 (36,000)	15 778 (34,785)	19 505 (43,005)	15 638 (34,480)	19 505 (43,005)	25 945 (57,200)	16 828 (37,100)	18 144 (40,000)	

Trailer configurations - double drop (#1); single drop (#'s 8-9, 15, 17, 27-36); flat (#'s 2-7, 14, 16, 18-26, 37-38).

*Miscellaneous weights vary and are not listed in trailer load totals

Assembly

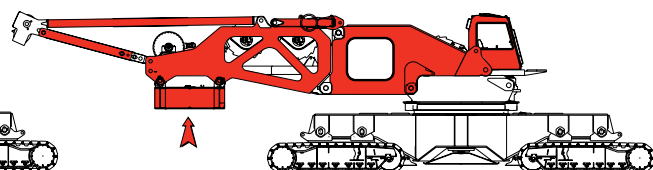
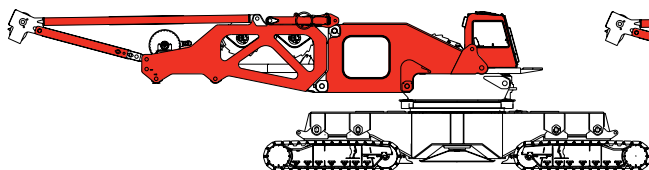
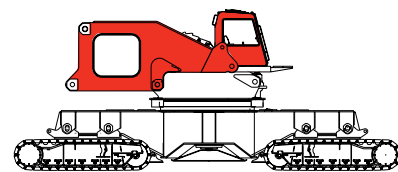
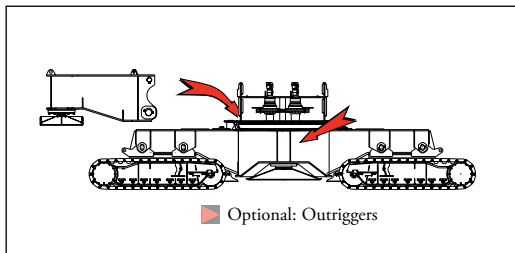
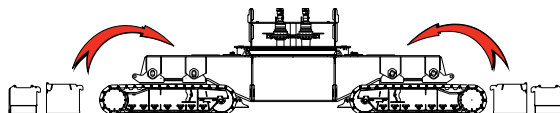
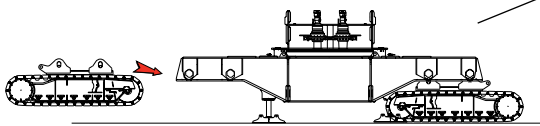
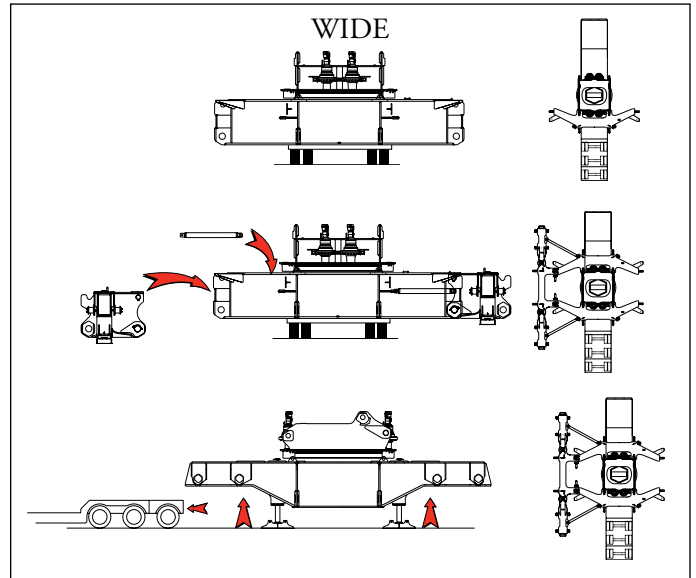
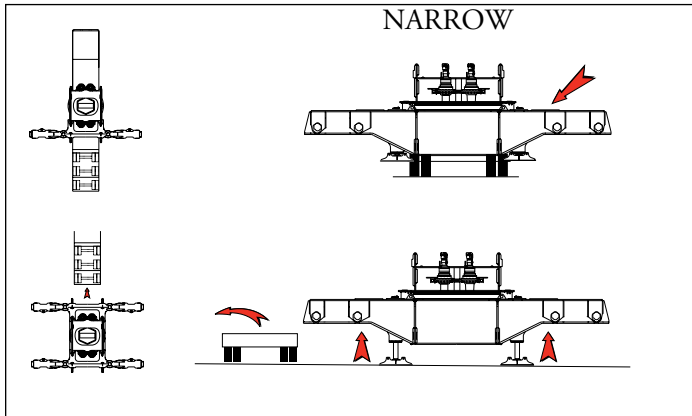
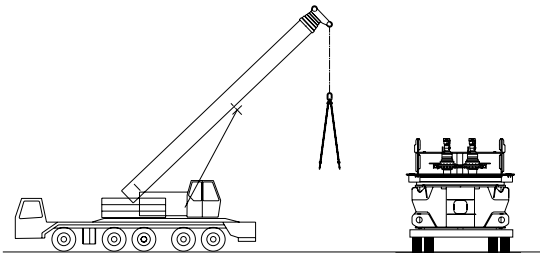

Assembly

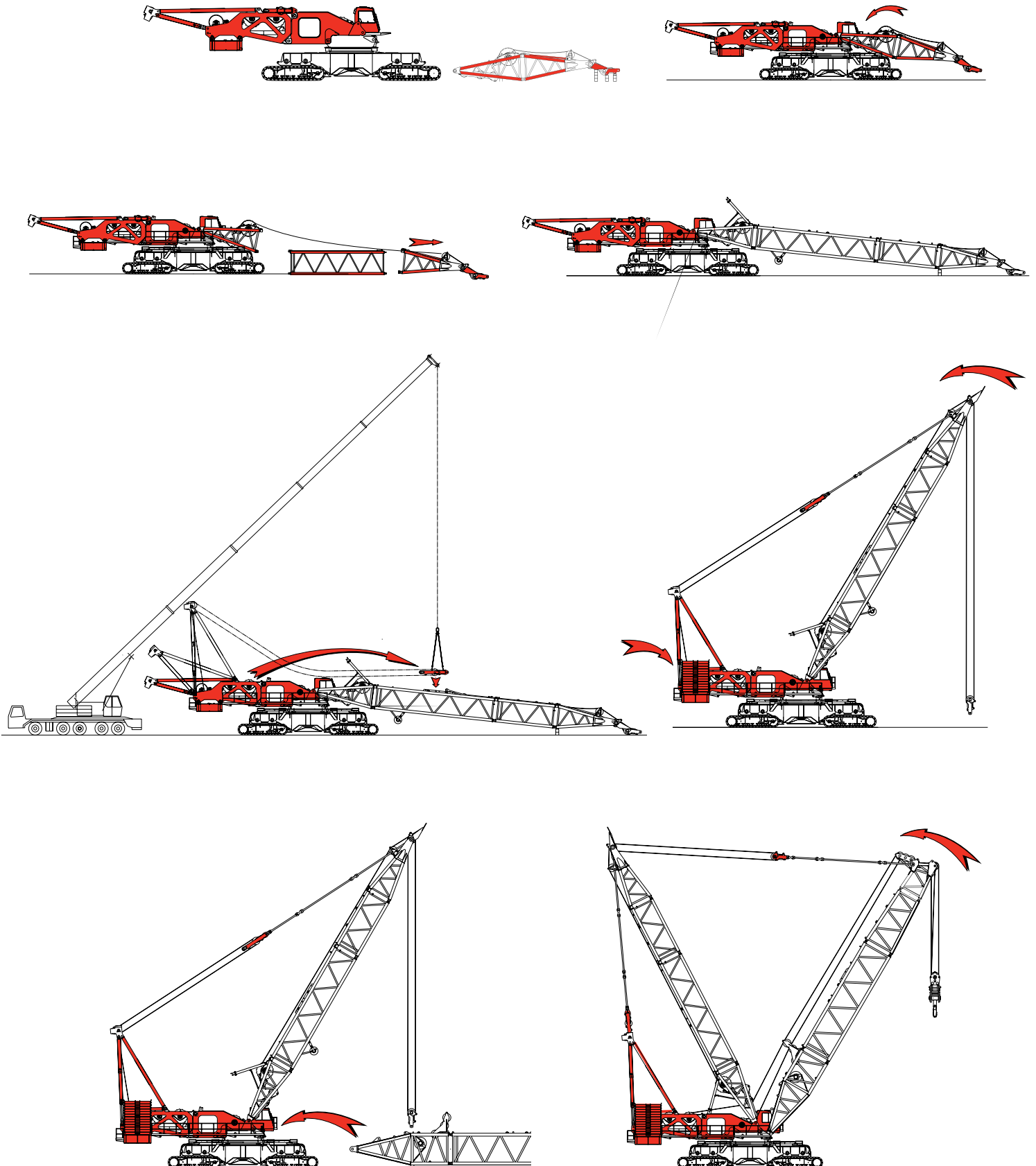

Performance data

Wire rope lengths Boom No. 80 Single drum - single boom point

Boom length	Whip line drum 2 or 3				Hoist line drum 1		Maximum required parts of line
	(1 part of line)		(2 parts of line)				
	m	(ft)	m	(ft)	m	(ft)	
30,5 (100)	88	(290)	130	(425)	975	(3,200)	28
36,6 (120)	101	(330)	145	(475)	1158	(3,800)	28
42,7 (140)	113	(370)	160	(525)	1341	(4,400)	28
48,8 (160)	125	(410)	183	(600)	1494	(4,900)	28
54,9 (180)	137	(450)	198	(650)	1554	(5,100)	26
61,0 (200)	149	(490)	221	(725)	1585	(5,200)	24
67,1 (220)	162	(530)	236	(775)	1615	(5,300)	22
73,2 (240)	174	(570)	251	(825)	1615	(5,300)	20
79,2 (260)	186	(610)	274	(900)	1615	(5,300)	18
85,3 (280)	198	(650)	290	(950)	1676	(5,500)	18
91,4 (300)	210	(690)	312	(1,025)	1676	(5,500)	16
97,5 (320)	223	(730)	328	(1,075)	1676	(5,500)	16
103,6 (340)	235	(770)	343	(1,125)	1676	(5,500)	14
109,7 (360)	247	(810)	366	(1,200)	1676	(5,500)	14

Note: Line lengths are based on single part lead line. Hoist line and whip line lengths given in table will allow hook to touch ground. When block travel below ground is required, add additional rope equal to parts of line times added travel distance. Hoisting distance or line pull may be limited when block travel below ground is required.

Wire rope lengths Boom No. 80 Tandem drums - tandem boom point

Boom length	Whip line drum 3				Hoist line				Total parts of line
	(1 part of line)		(2 parts of line)		Drum 1		Drum 2		
	m	(ft)	m	(ft)	m	(ft)	m	(ft)	
30,5 (100)	88	(290)	130	(425)	640	(2,100)	640	(2,100)	36
36,6 (120)	101	(330)	145	(475)	701	(2,300)	701	(2,300)	32
42,7 (140)	113	(370)	160	(525)	792	(2,600)	792	(2,600)	32
48,8 (160)	125	(410)	183	(600)	792	(2,600)	792	(2,600)	28

Note: Hoist line lengths are based on tandem drums both reeved to main load block. Each drum is dead ended in main load block reeving. Total parts of line requires using both drums 1 and 2.

Hoist line and whip line lengths given in table will allow hook to touch ground. When block travel below ground is required, add additional rope equal to parts of line times added travel distance. Hoisting distance or line pull may be limited when block travel below ground is required.

Performance data

Wire rope lengths Boom No. 80-81 Single drum

Boom length m (ft)	Whip line drum 2 or 3				Hoist line drum 1		Maximum required parts of line
	(1 part of line)		(2 parts of line)		m	(ft)	
54,9 (180)	137	(450)	198	(650)	1 676	(5,500)	28
61,0 (200)	149	(490)	221	(725)	1 676	(5,500)	24
67,1 (220)	162	(530)	236	(775)	1 676	(5,500)	22
73,2 (240)	174	(570)	251	(825)	1 676	(5,500)	20
79,2 (260)	186	(610)	274	(900)	1 676	(5,500)	18
85,3 (280)	198	(650)	290	(950)	1 676	(5,500)	18
91,4 (300)	210	(690)	312	(1,025)	1 676	(5,500)	16
97,5 (320)	223	(730)	328	(1,075)	1 676	(5,500)	16+
103,6 (340)	235	(770)	343	(1,125)	1 676	(5,500)	14
109,7 (360)	247	(810)	366	(1,200)	1 676	(5,500)	14
115,8 (380)	259	(770)	381	(1,125)	1 676	(5,500)	12
121,9 (400)	271	(810)	404	(1,200)	1 676	(5,500)	12

Note: Line lengths are based on single part lead line. Hoist line and whip line lengths given in table will allow hook to touch ground. When block travel below ground is required, add additional rope equal to parts of line times added travel distance. Hoisting distance or line pull may be limited when block travel below ground is required.

Drum capacities - wire rope

Drum 1, 2, 3, 6 (Hoist or whip)	Maximum length	Number of layers
32 mm wire rope*	1 475 m (4,840 ft)	10

*7 m (22') is deducted from maximum spooling capacities for 3 dead wraps per drum.

Drum identification

Drum number	Function
1	Front load drum - standard
2	Rear load drum - standard
3	Auxiliary load drum or luffing hoist - optional
4	Boom hoist - standard
5	Mast hoist - standard
6	Auxiliary load drum - optional

Wire rope specifications

Boom No. 80
- or -
Boom No. 80-81
- or -
Luffing jib No. 81 on
boom No. 80

Function	5:1 safety factor rotation resistant regular right hand lay 2 160 N/mm ² Hoist or whip line
Part number	No. 719413
Size wire rope	32 mm —
Minimum breaking strength	110 680 kg (244,000 lb)
Maximum load	22 140 kg (48,800 lb)
Per line approximate weight	4,81 kg/m (3.23 lb/ft)

Working weight

Configuration	kg (lb)
30,5 m (100') No. 80 Boom	814 683 (1,796,070)
121,9 m (400') No. 80-81 long-reach boom	866 194 (1,909,630)

Typical working weight includes: hydraulic reservoirs full, fuel half-full, drums loaded with standard lengths of wire rope, upper boom point, 544 mt (600 t) hook block, and 23,0 mt (25 t) weight ball.

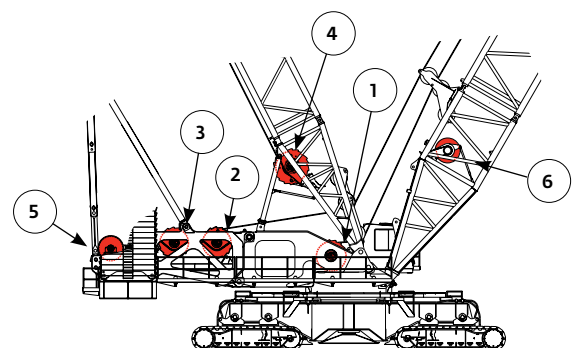

Performance data

Drums 1 & 2 - 217 kN (48,800 lb)										
Line pull kg (lb)	Single line pull/single line speed*									
	m/min (ft/min)									
Layer	1	2	3	4	5	6	7	8	9	10
0 (0)	91 (300)	84 (274)	99 (326)	114 (376)	107 (350)	123 (402)	130 (426)	138 (452)	146 (478)	153 (503)
22,2 (5,000)	89 (293)	82 (269)	97 (318)	111 (366)	104 (342)	119 (389)	126 (413)	133 (437)	141 (461)	148 (485)
44,5 (10,000)	88 (287)	80 (264)	94 (309)	109 (355)	101 (332)	115 (378)	122 (400)	129 (431)	135 (445)	142 (466)
66,7 (20,000)	83 (273)	77 (252)	89 (294)	102 (334)	96 (314)	108 (354)	113 (373)	129 (422)	125 (410)	130 (428)
133,4 (30,000)	80 (261)	73 (242)	85 (279)	92 (302)	90 (297)	93 (307)	95 (312)	120 (392)	98 (322)	100 (327)
178,0 (40,000)	70 (230)	69 (226)	71 (235)	74 (245)	73 (240)	76 (249)	77 (254)	96 (317)	81 (265)	82 (269)
217 (48,800)	61 (199)	59 (194)	62 (204)	65 (213)	64 (208)	67 (219)	69 (224)	79 (259)	71 (233)	72 (238)

NOTE: Line pull is infinitely variable.
*Based on lagging diameter of 660 mm (26").

Drum 3 - 217 kN (48,800 lb)										
Line pull kg (lb)	Single line pull/single line speed*									
	m/min (ft/min)									
Layer	1	2	3	4	5	6	7	8	9	10
0 (0)	88 (288)	96 (315)	104 (342)	112 (368)	120 (395)	129 (422)	137 (448)	145 (475)	153 (502)	161 (528)
22,2 (5,000)	86 (281)	93 (306)	101 (331)	109 (356)	116 (381)	124 (406)	131 (430)	138 (454)	146 (479)	153 (503)
44,5 (10,000)	83 (273)	91 (297)	98 (320)	105 (344)	112 (367)	119 (389)	126 (412)	132 (434)	139 (456)	146 (478)
66,7 (20,000)	79 (258)	85 (279)	91 (299)	97 (319)	103 (338)	109 (357)	111 (363)	112 (366)	113 (370)	114 (373)
133,4 (30,000)	73 (241)	74 (244)	75 (247)	77 (251)	77 (254)	78 (257)	79 (260)	80 (263)	81 (267)	82 (270)
178,0 (40,000)	58 (189)	59 (193)	60 (196)	61 (199)	62 (202)	62 (205)	64 (209)	65 (212)	66 (215)	66 (218)
217 (48,800)	49 (161)	50 (165)	51 (168)	52 (171)	53 (174)	54 (178)	55 (181)	56 (184)	57 (187)	58 (190)

NOTE: Line pull is infinitely variable.
*Based on drum diameter of 660 mm (26").

Drums and laggings - liftcrane							
Application	Drums						
	Drum location	Drum part number	Drum type	Drum diameter	Drum width	Wire rope size	
Basic liftcrane	Hoist	Drum 1	192244	Grooved	660 mm (26")	1 664 mm (65-1/2")	32 mm —
	Whip	Drum 2	192244	Grooved	660 mm (26")	1 664 mm (65-1/2")	32 mm —
	Whip (optional)	Drum 3	192244	Grooved	660 mm (26")	1 664 mm (65-1/2")	32 mm —

Boom combinations

No. 80 Main boom combinations			
Boom length m (ft)	Luffing jib inserts		
	6,1 m (20 ft)	12,2 m* (40 ft)*	12,2 m (40 ft)
30,5 (100)	—	—	—
36,6 (120)	1	—	—
42,7 (140)	—	1	—
48,8 (160)	1	1	—
54,9 (180)	—	2	—
61,0 (200)	1	2	—
67,1 (220)	—	2	1
73,2 (240)	1	2	1
79,2 (260)	—	2	2
85,3 (280)	1	2	2
91,4 (300)	—	2	3
97,5 (320)	1	2	3
103,6 (340)	—	2	4
109,7 (360)	1	2	4

*Inserts do not require boom support strap.

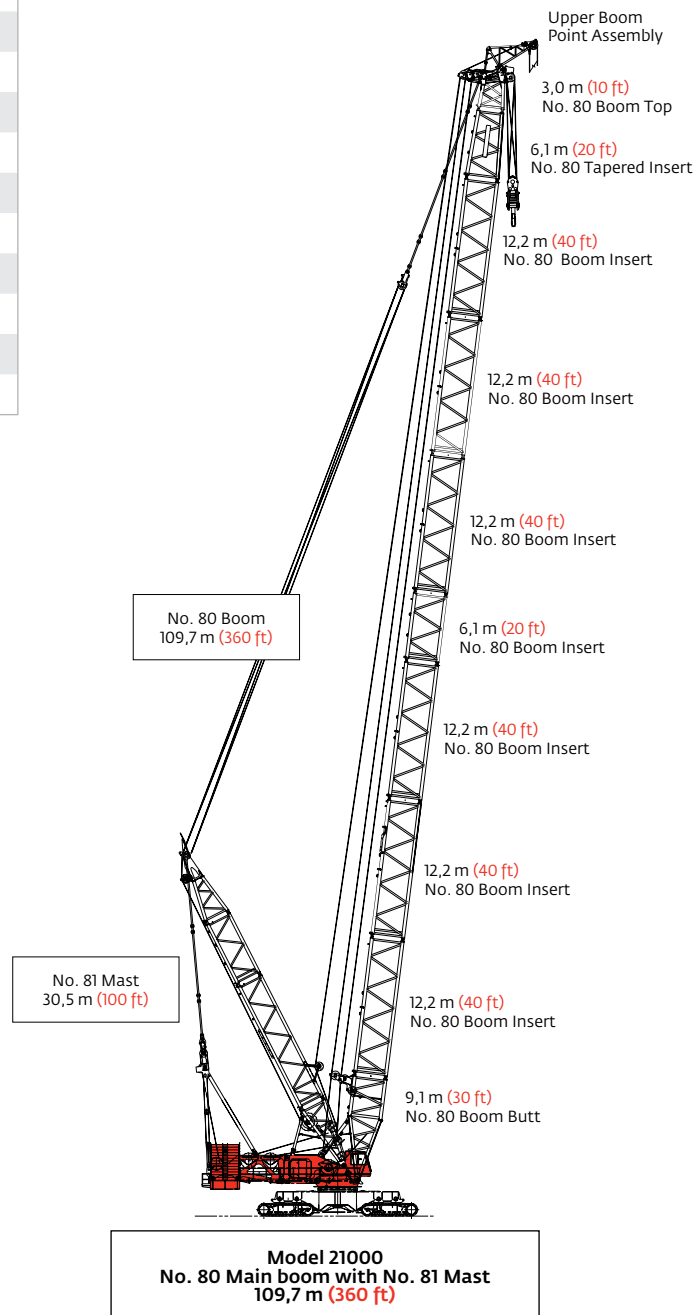

Boom combinations

No. 80-81 Main boom combinations					
Boom length m (ft)	No. 80 Inserts			No. 81 Inserts	
	6,1 m (20 ft)	12,2 m* (40 ft)*	12,2 m (40 ft)	6,1 m (20 ft)	12,2 m (40 ft)
54,9 (180)	—	—	—	—	—
61,0 (200)	1	—	—	—	—
67,1 (220)	—	1	—	—	—
73,2 (240)	1	1	—	—	—
79,2 (260)	—	1	1	—	—
85,3 (280)	1	1	1	—	—
91,4 (300)	1	1	1	1	—
97,5 (320)	1	1	1	—	1
103,6 (340)	1	1	1	1	1
109,7 (360)	1	1	1	—	2
115,8 (380)	1	1	1	1	2
121,9 (400)	1	1	1	—	3

*Inserts do not require boom support strap.

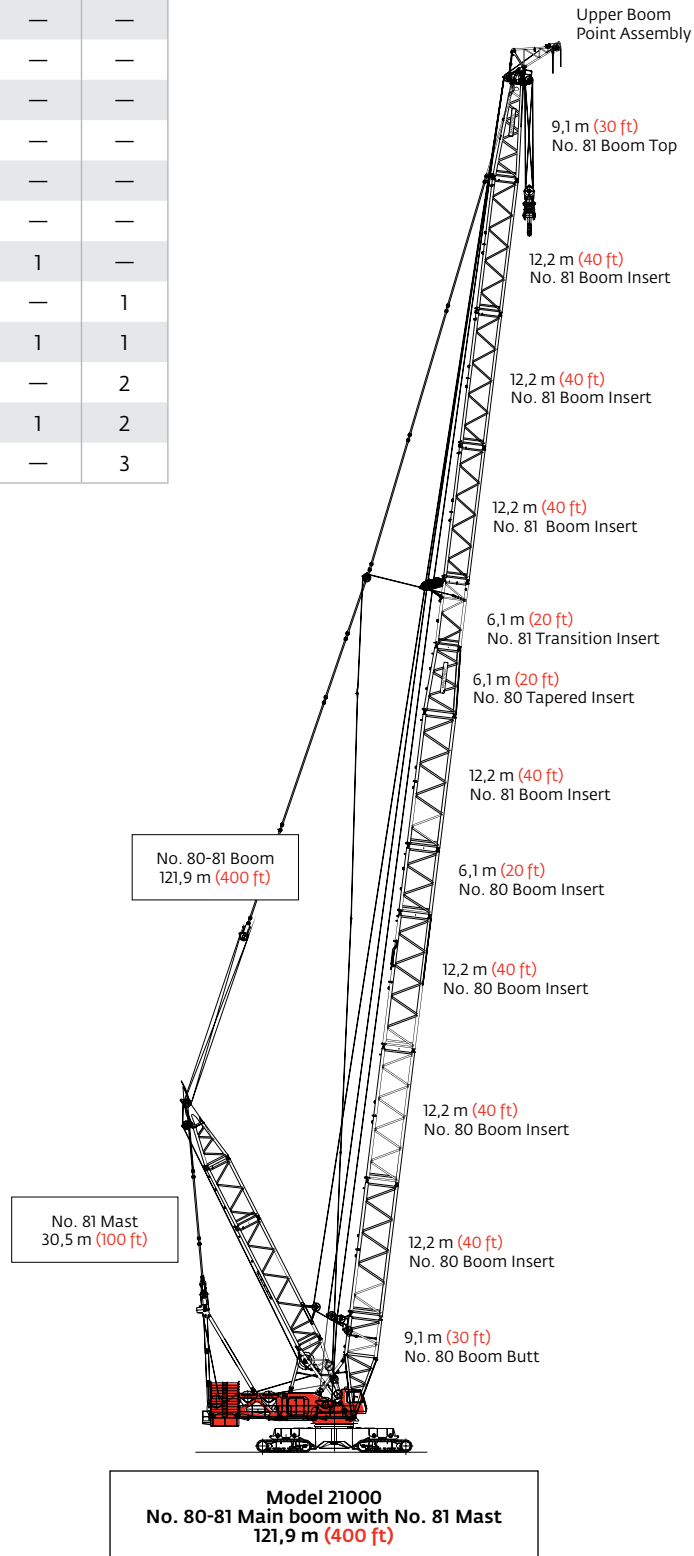

Heavy-lift boom range diagram

No. 80 Heavy-lift boom

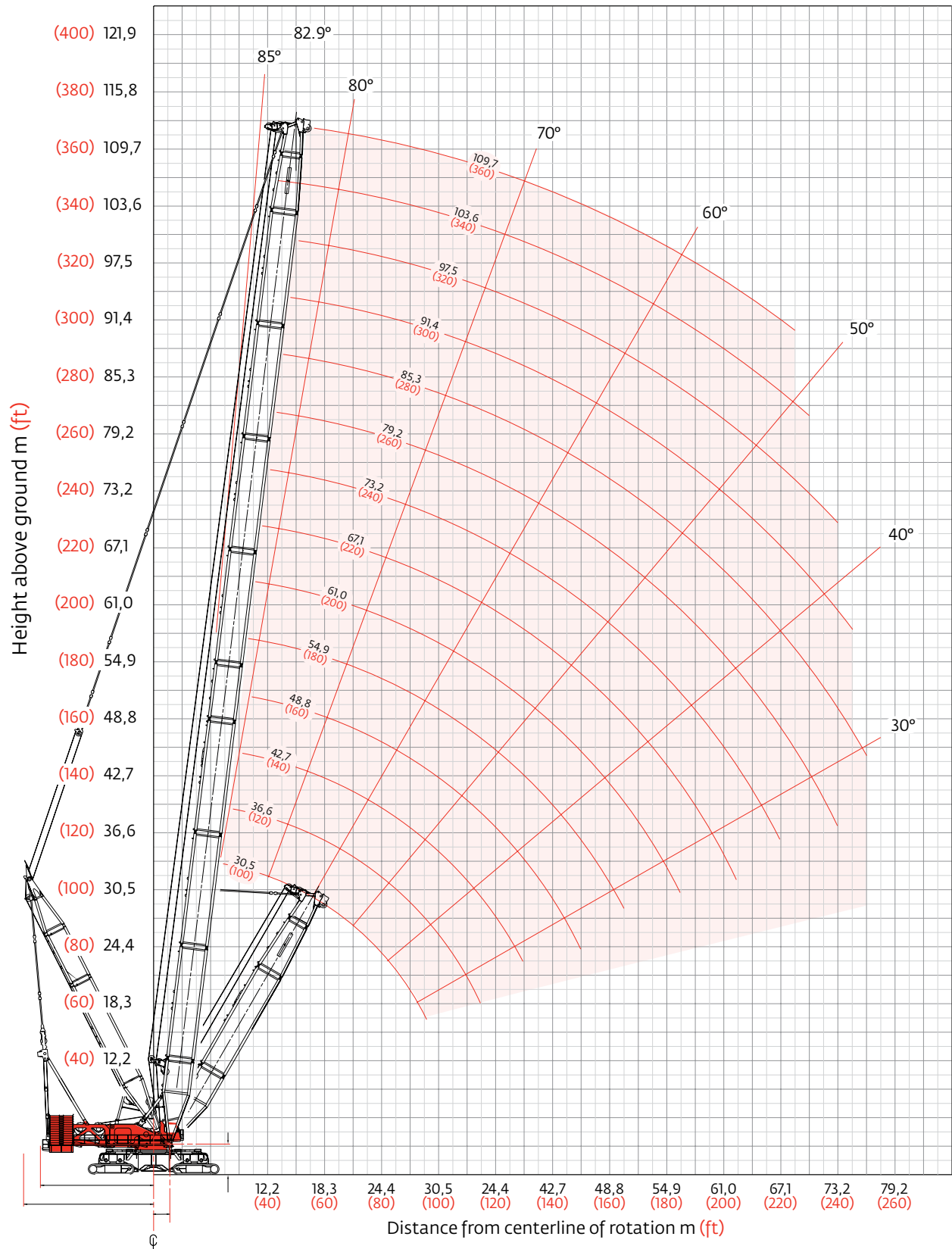

Heavy-lift boom load charts

Liftcrane boom capacities												
Boom No. 80 with 30,5 m (100') Mast												
Boom m (ft) Radius	240 720 kg (530,700 lb) Crane counterweight						90 720 kg (200,000 lb) carbody counterweight					
	360° Rating for wide crawler arrangement or narrow crawler arrangement with outriggers kg (lb) x 1 000											
	30,5 (100)	36,6 (120)	42,7 (140)	48,8 (160)	54,9 (180)	61,0 (200)	73,2 (240)	85,3 (280)	91,4 (300)	97,5 (320)	103,6 (340)	109,7 (360)
7,0 (23)	756,6 (1668.2)											
8,0 (26)	667,4 (1485.0)	665,0 (1478.8)										
9,0 (30)	595,8 (1293.6)	593,0 (1287.6)	591,8 (1283.8)	— (1277.5)								
10,0 (34)	537,5 (1144.1)	534,8 (1138.3)	533,1 (1134.7)	530,3 (1128.6)	— (1130.8)							
12,0 (40)	448,3 (972.7)	445,7 (967.2)	444,2 (963.7)	441,5 (957.8)	442,5 (960.2)	440,5 (955.7)	— (948.2)					
16,0 (50)	333,6 (774.1)	331,2 (768.8)	329,8 (765.6)	327,2 (759.9)	328,4 (762.5)	326,3 (757.9)	322,9 (750.3)	319,1 (742.1)	317,7 (737.1)	316,1 (733.5)		
18,0 (60)	292,9 (633.8)	290,9 (629.4)	289,5 (626.5)	287,2 (621.5)	288,5 (624.5)	286,5 (620.3)	283,3 (613.5)	279,9 (606.1)	277,8 (601.6)	276,3 (598.4)	274,5 (593.7)	272,8 (589.9)
22,0 (70)	231,6 (529.6)	229,7 (525.3)	228,4 (522.5)	226,3 (517.7)	227,6 (520.7)	225,7 (516.4)	222,5 (509.4)	219,0 (501.8)	216,9 (497.2)	215,4 (493.9)	213,3 (489.2)	211,7 (485.7)
24,0 (80)	208,9 (452.1)	207,0 (447.9)	205,8 (445.2)	203,6 (440.5)	205,0 (443.6)	203,0 (439.2)	199,8 (432.1)	196,4 (424.4)	194,2 (419.6)	192,7 (416.3)	190,5 (411.5)	188,9 (408.0)
26,0 (90)	189,8 (392.0)	187,9 (388.1)	186,7 (385.5)	184,6 (380.8)	186,1 (384.1)	184,0 (379.6)	180,8 (372.4)	177,3 (364.6)	175,1 (359.7)	173,5 (356.4)	171,4 (351.6)	169,8 (348.0)
30,0 (100)		157,5 (340.4)	156,3 (337.9)	154,2 (333.3)	155,7 (336.7)	153,7 (332.1)	150,4 (324.8)	146,8 (317.0)	144,6 (312.1)	143,1 (308.7)	140,9 (303.8)	139,2 (300.2)
34,0 (110)		134,2 (301.4)	133,2 (299.1)	131,1 (294.6)	132,7 (298.0)	130,6 (293.4)	127,3 (286.1)	123,7 (278.2)	121,5 (273.3)	119,9 (269.9)	117,7 (265.0)	116,0 (261.3)
36,0 (120)			123,5 (266.7)	121,5 (262.4)	123,1 (265.9)	121,0 (261.3)	117,7 (253.9)	114,0 (245.9)	111,7 (240.4)	110,0 (236.4)	107,6 (230.5)	105,6 (226.1)
40,0 (130)			— (236.1)	103,7 (232.2)	106,5 (238.2)	104,0 (232.9)	100,3 (224.7)	96,0 (215.3)	93,3 (209.4)	91,5 (205.3)	88,7 (199.2)	86,7 (194.8)
44,0 (150)				88,6 (182.8)	91,4 (189.3)	89,1 (184.0)	85,3 (175.6)	80,9 (166.1)	78,2 (160.1)	76,3 (155.9)	73,6 (149.7)	71,5 (145.2)
48,0 (160)					78,9 (169.4)	76,6 (164.2)	72,8 (155.8)	68,5 (146.3)	65,7 (140.1)	63,8 (136.0)	61,0 (129.8)	58,9 (125.3)
52,0 (170)						66,0 (146.7)	62,3 (138.4)	57,9 (128.8)	55,1 (122.6)	53,3 (118.5)	50,4 (112.2)	48,4 (107.7)
54,0 (180)						61,3 (131.0)	57,6 (122.9)	53,2 (113.3)	50,5 (107.1)	48,6 (102.9)	45,7 (96.7)	43,7 (92.1)
60,0 (200)							45,4 (96.4)	41,1 (86.9)	38,3 (80.7)	36,4 (76.6)	33,5 (70.3)	31,5 (65.7)
64,0 (210)							38,5 (85.0)	34,3 (75.6)	31,4 (69.4)	29,6 (65.3)	26,7 (59.0)	24,6 (54.4)
66,0 (220)							35,4 (74.5)	31,2 (65.3)	28,4 (59.2)	26,5 (55.0)	23,6 (48.7)	21,6 (44.2)
70,0 (230)								25,4 (55.9)	22,7 (49.8)	20,8 (45.7)	17,9 (39.3)	
74,0 (240)								20,3 (47.2)	17,6 (41.1)	— (37.0)		
76,0 (250)								17,9 (39.1)				

Meets ANSI B30.5 Requirements - Capacities do not exceed 75% of static tipping load.
 NOTICE: This capacity chart is for reference only and must not be used for lifting purposes.

Long-reach top range diagram

No. 80-81 Long-reach boom

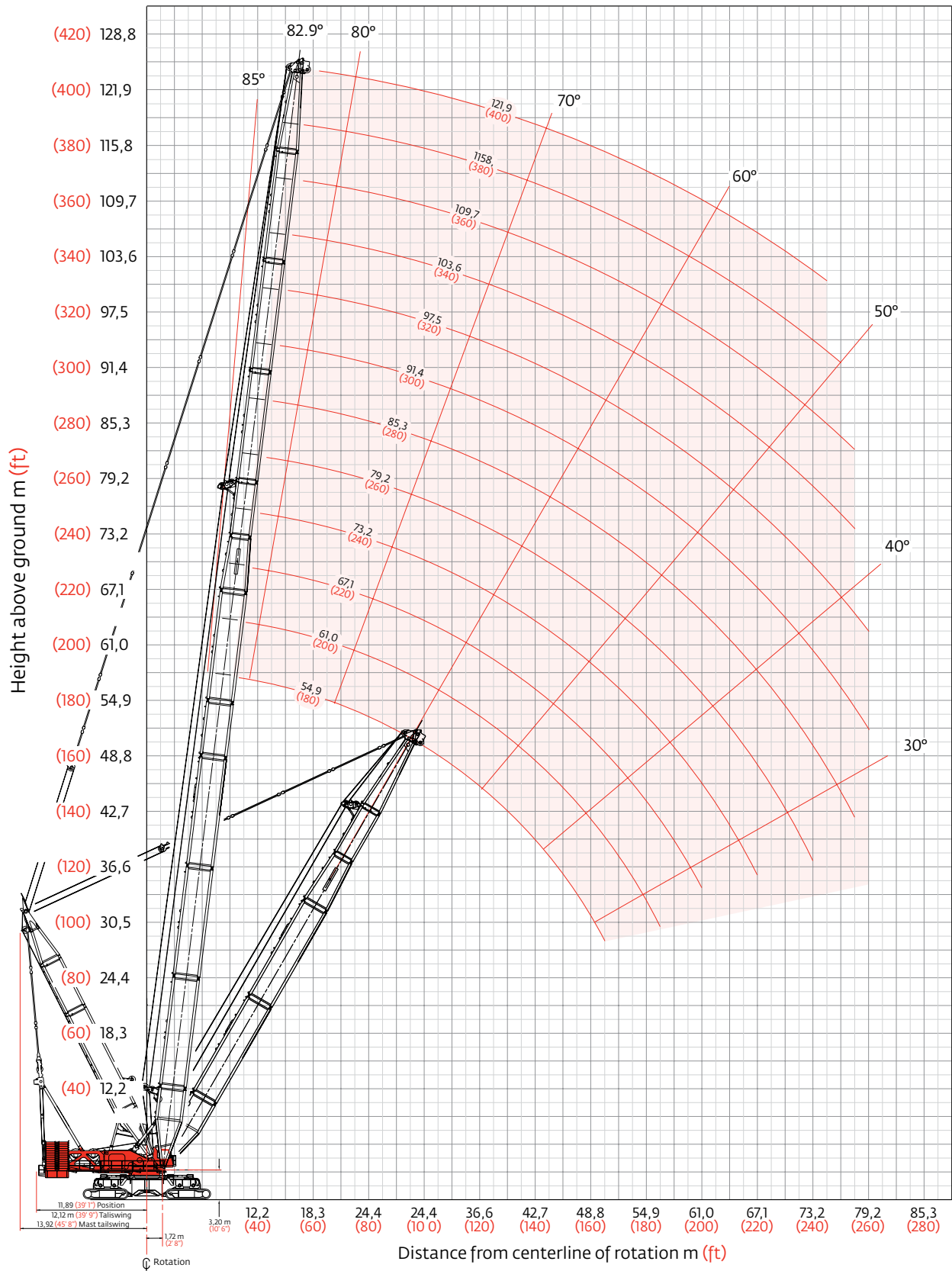

Long-reach top load chart

Liftcrane boom capacities												
Boom No. 80-81 with 30,5 m (100') mast												
Boom m (ft) Radius	240 720 kg (530,700 lb) Crane Counterweight						90 720 kg (200,000 lb) Carbody Counterweight					
	360° Rating for wide crawler arrangement or narrow crawler arrangement with outriggers kg (lb) x1 000											
	54,9 (180)	61,0 (200)	67,1 (220)	73,2 (240)	79,2 (260)	85,3 (280)	91,4 (300)	97,5 (320)	103,6 (340)	109,7 (360)	115,8 (380)	121,9 (400)
9,8 (32)	544,3 (1200.0)											
12,0 (40)	446,4 (968.8)	443,5 (962.2)	443,0 (957.7)	— (948.4)								
14,0 (45)	381,6 (859.5)	378,8 (853.2)	376,7 (848.7)	374,6 (843.7)	373,6 (840.3)	371,3 (835.2)						
16,0 (50)	332,3 (771.1)	329,5 (764.9)	327,5 (760.5)	325,2 (755.4)	323,7 (752.0)	321,4 (746.9)	321,2 (744.5)	320,7 (743.6)				
18,0 (60)	292,4 (633.2)	289,9 (627.7)	288,0 (623.5)	285,8 (619.0)	284,4 (615.9)	282,3 (611.3)	281,3 (609.3)	281,0 (608.8)	280,1 (606.1)	279,6 (604.9)	— (585.6)	— (504.8)
22,0 (70)	231,6 (529.4)	229,1 (524.0)	227,3 (519.9)	225,1 (515.2)	223,7 (512.1)	221,6 (507.4)	220,6 (505.3)	220,3 (504.7)	219,1 (501.9)	218,6 (500.9)	217,5 (498.4)	210,1 (467.6)
24,0 (80)	209,0 (452.2)	206,5 (446.9)	204,7 (442.9)	202,5 (438.1)	201,1 (435.0)	199,0 (430.2)	198,0 (428.1)	197,7 (427.4)	196,4 (424.5)	195,9 (423.5)	194,8 (420.9)	195,4 (419.5)
26,0 (90)	190,0 (392.6)	187,6 (387.4)	185,7 (383.4)	183,6 (378.6)	182,1 (375.4)	179,9 (370.6)	178,9 (368.4)	178,7 (367.7)	177,4 (364.8)	176,9 (363.7)	175,7 (361.1)	175,0 (359.7)
30,0 (100)	159,6 (345.2)	157,2 (340.0)	155,4 (336.0)	153,3 (331.2)	151,8 (328.0)	149,6 (323.1)	148,6 (321.0)	148,3 (320.3)	147,0 (317.3)	146,5 (316.2)	145,2 (313.5)	144,6 (312.0)
34,0 (110)	136,5 (306.5)	134,2 (301.4)	132,5 (297.5)	130,2 (292.6)	128,8 (289.4)	126,6 (284.5)	125,6 (282.3)	125,2 (281.6)	123,9 (278.6)	123,3 (277.4)	122,1 (274.7)	121,5 (273.3)
36,0 (120)	126,9 (274.3)	124,6 (269.3)	122,9 (265.4)	120,7 (260.5)	119,2 (257.3)	117,0 (252.4)	116,0 (250.2)	115,7 (249.5)	114,3 (246.4)	113,8 (245.3)	112,5 (242.5)	111,8 (241.0)
40,0 (130)	110,6 (247.1)	108,4 (242.2)	106,6 (238.3)	104,3 (233.4)	102,8 (230.0)	100,0 (224.0)	98,9 (221.6)	98,7 (221.2)	97,1 (217.7)	96,6 (216.6)	95,2 (213.5)	94,4 (211.8)
44,0 (150)	96,5 (200.4)	94,0 (195.0)	92,0 (190.6)	89,4 (184.8)	87,7 (181.2)	85,0 (175.0)	83,8 (172.6)	83,6 (172.1)	82,0 (168.4)	81,5 (167.3)	80,0 (164.0)	79,3 (162.3)
48,0 (160)	84,0 (180.4)	81,6 (175.2)	79,6 (170.9)	77,0 (165.1)	75,3 (161.4)	72,5 (155.3)	71,4 (152.8)	71,2 (152.3)	69,5 (148.5)	69,0 (147.4)	67,5 (144.1)	66,7 (142.4)
52,0 (170)		71,0 (157.7)	69,2 (153.6)	66,5 (147.7)	64,9 (144.1)	62,1 (137.9)	60,9 (135.4)	60,6 (134.8)	59,0 (131.1)	58,4 (129.9)	56,9 (126.6)	56,2 (124.9)
54,0 (180)		66,3 (142.1)	64,5 (138.1)	61,9 (132.3)	60,2 (128.6)	57,4 (122.5)	56,2 (119.9)	56,0 (119.4)	54,3 (115.6)	53,7 (114.4)	52,2 (111.1)	51,5 (109.3)
58,0 (190)			56,2 (124.3)	53,5 (118.5)	51,9 (114.8)	49,1 (108.7)	47,9 (106.1)	47,7 (105.6)	46,0 (101.8)	45,4 (100.6)	43,9 (97.2)	43,1 (95.5)
60,0 (200)			52,3 (111.7)	49,8 (106.0)	48,1 (102.4)	45,3 (96.3)	44,2 (93.7)	43,9 (93.2)	42,2 (89.3)	41,6 (88.1)	40,1 (84.8)	39,3 (83.0)
64,0 (210)				42,9 (94.7)	41,3 (91.2)	38,5 (85.0)	37,4 (82.5)	37,2 (82.0)	35,4 (78.1)	34,8 (76.9)	33,3 (73.5)	32,5 (71.8)
66,0 (220)				39,8 (84.3)	38,2 (80.9)	35,4 (74.8)	34,3 (72.3)	34,1 (71.8)	32,3 (67.9)	31,8 (66.7)	30,2 (63.3)	29,4 (61.5)
70,0 (230)					32,5 (71.4)	29,8 (65.4)	28,6 (62.9)	28,4 (62.5)	26,7 (58.6)	26,1 (57.4)	24,6 (54.0)	23,8 (52.2)
74,0 (240)					— (62.7)	24,7 (56.8)	23,6 (54.4)	23,4 (53.9)	21,6 (50.0)	21,1 (48.8)	19,5 (45.4)	18,8 (43.7)
76,0 (250)						22,3 (48.8)	21,2 (46.4)	21,0 (46.0)	19,3 (42.1)	18,7 (40.9)	17,2 (37.5)	
78,0 (260)							19,0 (39.1)	18,8 (38.7)				

Meets ANSI B30.5 Requirements - Capacities do not exceed 75% of static tipping load.
 NOTICE: This capacity chart is for reference only and must not be used for lifting purposes.

Outline dimensions

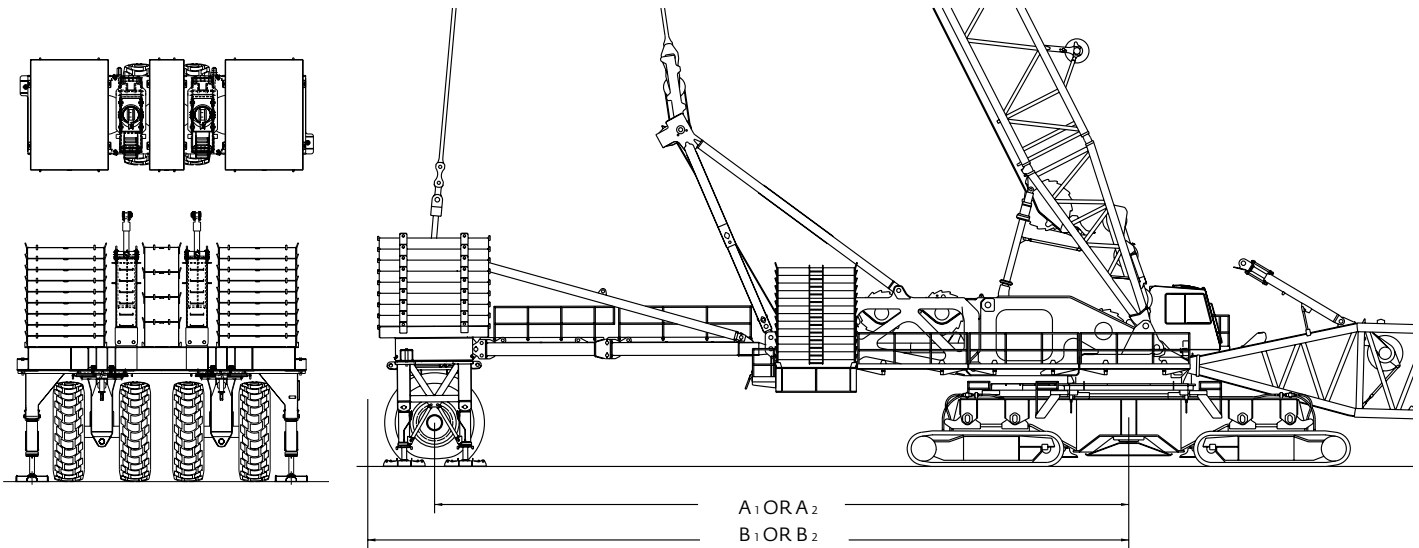

WHEELED COUNTERWEIGHT

A₁ = ONE-PIECE SHEAR FRAME 18,0 M (59' 0")
 A₂ = TWO-PIECE SHEAR FRAME 22,0 M (72' 0")

B₁ = ONE-PIECE SHEAR FRAME 20,4 M (67' 0")
 B₂ = TWO-PIECE SHEAR FRAME 24,4 M (80' 0")

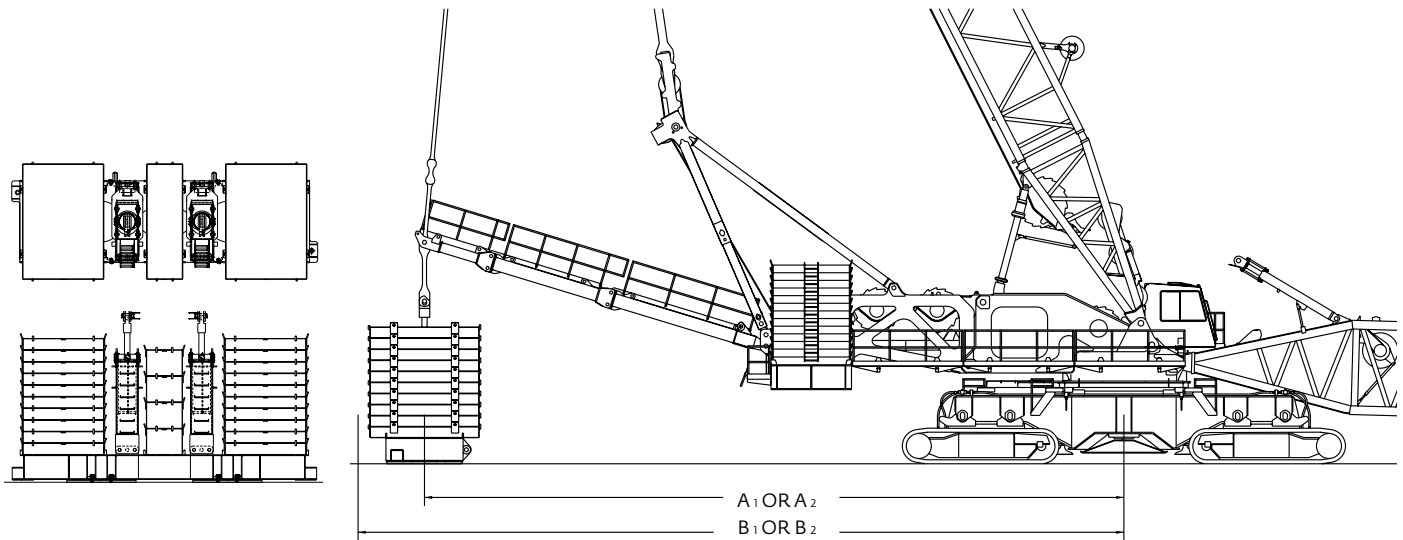

FREE HANGING COUNTERWEIGHT

A₁ = TWO-PIECE SHEAR FRAME 17,9 M (58' 9")
 A₂ = THREE-PIECE SHEAR FRAME 22,1 M (72' 6")

B₁ = TWO-PIECE SHEAR FRAME 20,1 M (66' 0")
 B₂ = THREE-PIECE SHEAR FRAME 24,2 M (79' 6")

Outline dimensions

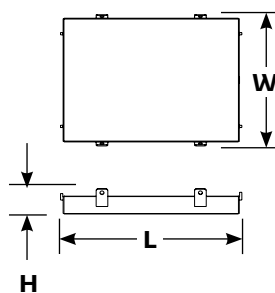
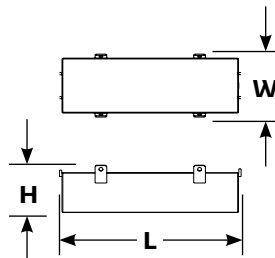
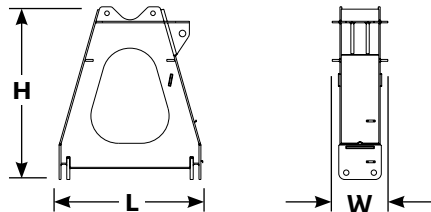
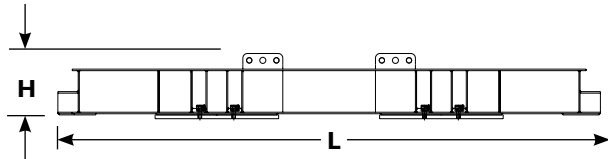
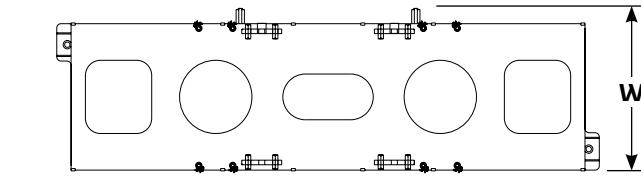
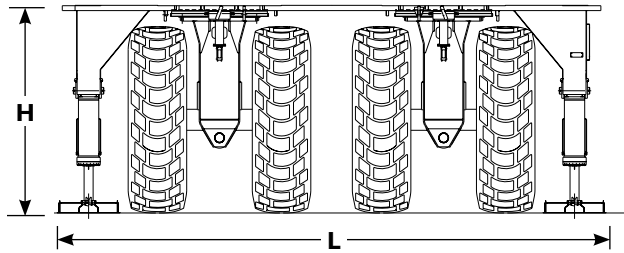
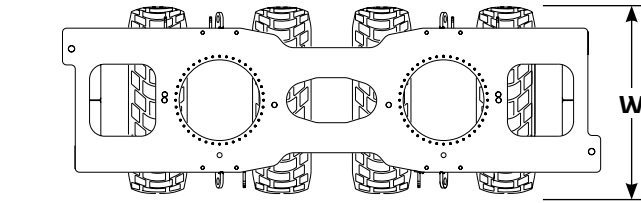

Wheeled carrier		x 1
Length	9,14 m	30' 0"
Width	3,55 m	11' 8"
Height	3,55 m	11' 8"
Weight	63 299 kg	139,555 lb

Counterweight tray		x 1
Length	9,14 m	30' 0"
Width	2,71 m	8' 11"
Height	1,03 m	3' 5"
Weight	15 381 kg	33,910 lb

A-Frame		x 2
Length	2,38 m	7' 10"
Width	0,92 m	3' 1"
Height	2,87 m	9' 5"
Weight	3 658 kg	8,065 lb

Center counterweight box		x 4
Length	3,56 m	11' 8"
Width	1,24 m	4' 10"
Height	0,93 m	3' 1"
Weight	19 958 kg	44,000 lb

Side counterweight box		x 18, 20
Length	3,56 m	11' 8"
Width	2,59 m	8' 6"
Height	0,50 m	1' 8"
Weight	19 958 kg	44,000 lb

Note: Wheeled carrier requires 18 counterweights, hanging tray requires 20 counterweights.

Option

Outline dimensions

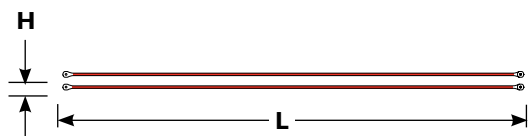
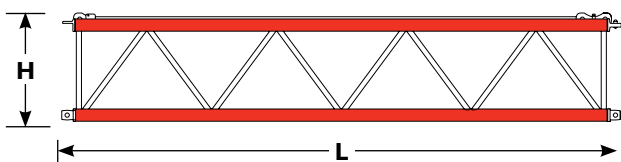
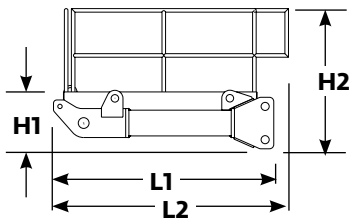
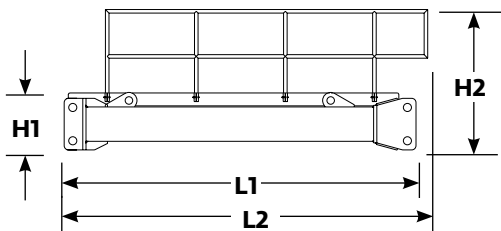
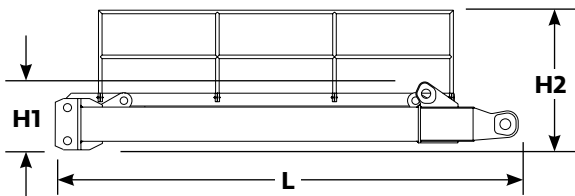
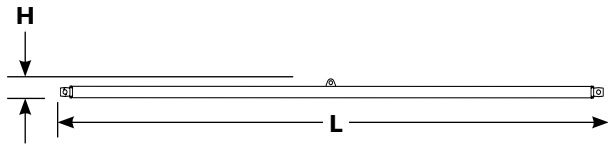
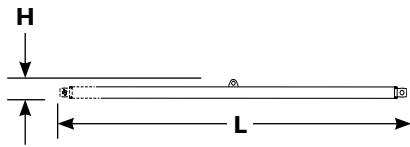

Struts - 5,5 m (18')		
		x 2
Length	5,79 m	19' 0"
Width	0,28 m	0' 11"
Height	0,28 m	0' 11"
Weight	757 kg	1,670 lb

Note: For wheeled counterweight.

Struts - 9,1 m (30')		
		x 2
Length	9,45 m	31' 0"
Width	0,28 m	0' 11"
Height	0,28 m	0' 11"
Weight	1183 kg	2,610 lb

Note: For wheeled counterweight.

Front shear frame and railings		
		x 1
Length	5,66 m	18' 7"
Width	3,40 m	11' 2"
Height 1	0,81 m	2' 8"
Weight	4177 kg	9,210 lb

Note: Shown with railings attached in operating position.

Height 2 1,66 m 5' 6"

Rear shear frame and railings		
		x 1
Length 1	4,40 m	14' 6"
Width	3,40 m	11' 2"
Height 1	0,67 m	2' 3"
Weight	3626 kg	7,995 lb

Note: Shown with railings attached in operating position.

Length 2 4,52 m 15' 1"

Height 2 1,66 m 5' 6"

Shear frame adapter and railings		
		x 1
Length 1	2,61 m	8' 7"
Width	3,40 m	11' 2"
Height 1	0,67 m	2' 3"
Weight	3225 kg	7,110 lb

Note: Shown with railings attached in operating position.

Length 2 2,77 m 9' 1"

Height 2 1,66 m 5' 6"

No. 81 Mast insert 12,2 m (40') and straps		
		x 1
Length	12,45 m	40' 10"
Width	3,38 m	11' 1"
Height	2,50 m	8' 3"
Weight	8085 kg	17,825 lb

Straps 8,1 m (26' 8")		
		x 2
Length	8,41 m	27' 6"
Width	0,08 m	0' 3"
Height	0,28 m	0' 11"
Weight	1238 kg	2,730 lb

Performance data

Wire rope lengths Boom No. 80 with MAX-ER® Tandem drums - single boom point

Boom length	Hoist line		
	Drum 1 or 2		Maximum required parts of line
	m	(ft)	
42,7 (140)	1 067	(3,500)	44
48,8 (160)	1 189	(3,900)	44
54,9 (180)	1 341	(4,400)	44
61,0 (200)	1 341	(4,400)	40
67,1 (220)	1 463	(4,800)	40
73,2 (240)	1 463	(4,800)	36
79,2 (260)	1 463	(4,800)	32
85,3 (280)	1 463	(4,800)	28
91,4 (300)	1 463	(4,800)	28

Note: Hoist line lengths are based on tandem drums both reeved to main load block. Each drum is dead ended in main load block reeving. Total parts of line requires using both drums 1 and 2.

Hoist line lengths given in table will allow hook to touch ground. When block travel below ground is required, add additional rope equal to parts of line times added travel distance. Hoisting distance or line pull may be limited when block travel below ground is required.

Wire rope lengths Boom No. 80 with MAX-ER® Tandem drums - single boom point

Boom length	Hoist line		
	Drum 1 or 2		Maximum required parts of line
	m	(ft)	
97,5 (320)	1 463	(4,800)	24
103,6 (340)	1 463	(4,800)	24
109,7 (360)	1 463	(4,800)	20
115,8 (380)	1 463	(4,800)	16

Note: Hoist line lengths are based on tandem drums, both reeved to main load block. Each drum is dead ended in main load block reeving. Total parts of line requires using both drums 1 and 2.

Hoist line lengths given in table will allow hook to touch ground. When block travel below ground is required, add additional rope equal to parts of line times added travel distance. Hoisting distance or line pull may be limited when block travel below ground is required.

Performance data

Wire rope lengths
Luffing jib No. 81 on
Boom No. 80 with MAX-ER®
Single drum - single jib point

Boom length m (ft)	Maximum parts of line for full hoisting range Jib length m (ft)										Hoist line drum 1		Hoist line drum 2			
	36,6 (120)	42,7 (140)	48,8 (160)	54,9 (180)	61,0 (200)	67,1 (220)	73,2 (240)	79,2 (260)	85,3 (280)	91,4 (300)	m	(ft)	(1 part of line)		(2 parts of line)	
													m	(ft)	m	(ft)
54,9 (180)	16	14	14	14	12	12	10	10	8	8	1 676	(5,500)	427	(1,400)	610	(2,000)
61,0 (200)	14	14	14	12	12	10	10	10	8	8	1 676	(5,500)	427	(1,400)	610	(2,000)
67,1 (220)	14	14	12	12	10	10	10	8	8	6	1 676	(5,500)	427	(1,400)	610	(2,000)
73,2 (240)	14	12	12	10	10	10	10	8	8	6	1 676	(5,500)	427	(1,400)	610	(2,000)
79,2 (260)	12	12	10	10	10	10	8	8	6	6	1 676	(5,500)	427	(1,400)	610	(2,000)
85,3 (280)	12	10	10	10	10	8	8	8	6	6	1 676	(5,500)	427	(1,400)	610	(2,000)
91,4 (300)	10	10	10	10	8	8	8	6	6	6	1 676	(5,500)	427	(1,400)	610	(2,000)
97,5 (320)	10	10	10	8	8	8	6	6	6	6	1 676	(5,500)	427	(1,400)	610	(2,000)
103,6 (340)	10	10	8	8	8	8	6	6	6	6	1 676	(5,500)	427	(1,400)	610	(2,000)

Note: Line lengths are based on single part lead line. Hoist line and whip line lengths given in table will allow hook to touch ground. When block travel below ground is required, add additional rope equal to parts of line times added travel distance. Hoisting distance or line pull may be limited when block travel below ground is required.

Wire rope lengths
Luffing jib No. 81 on
Boom No. 80 with MAX-ER®
Tandem drums - single jib point

Boom length m (ft)	Parts of line for maximum capacity Jib Length m (ft)						Hoist line drum 1		Hoist line drum 2	
	36,6 (120)	42,7 (140)	48,8 (160)	54,9 (180)	61,0 (200)	67,1 (220)	m	(ft)	m	(ft)
54,9 (180)	24	20	20	16	16	12	1 250	(4,100)	1 250	(4,100)
61,0 (200)	20	20	16	16	16	12	1 250	(4,100)	1 250	(4,100)
67,1 (220)	20	16	16	16	12		1 250	(4,100)	1 250	(4,100)
73,2 (240)	16	16	16	12	12		1 250	(4,100)	1 250	(4,100)
79,2 (260)	16	16	12	12			1 250	(4,100)	1 250	(4,100)
85,3 (280)	16	12	12				1 250	(4,100)	1 250	(4,100)
91,4 (300)	12	12					1 250	(4,100)	1 250	(4,100)

Note: Hoist line lengths are based on tandem drums both reeved to main load block. Each drum is dead ended in main load block reeving. Total parts of line requires using both drums 1 and 2.

Hoist line and whip line lengths given in table will allow hook to touch ground. When block travel below ground is required, add additional rope equal to parts of line times added travel distance. Hoisting distance or line pull may be limited when block travel below ground is required.

Boom combinations

No. 80 Main boom combinations		
Boom length m (ft)	Boom inserts	
	6,1 m (20 ft)	12,2 m (40 ft)
54,9 (180)	—	2
61,0 (200)	1	2
67,1 (220)	—	3
73,2 (240)	1	3
79,2 (260)	—	4
85,3 (280)	1	4
91,4 (300)	—	5
97,5 (320)	1	5
103,6 (340)	—	6
109,7 (360)	1	7
115,8 (380)	2	7

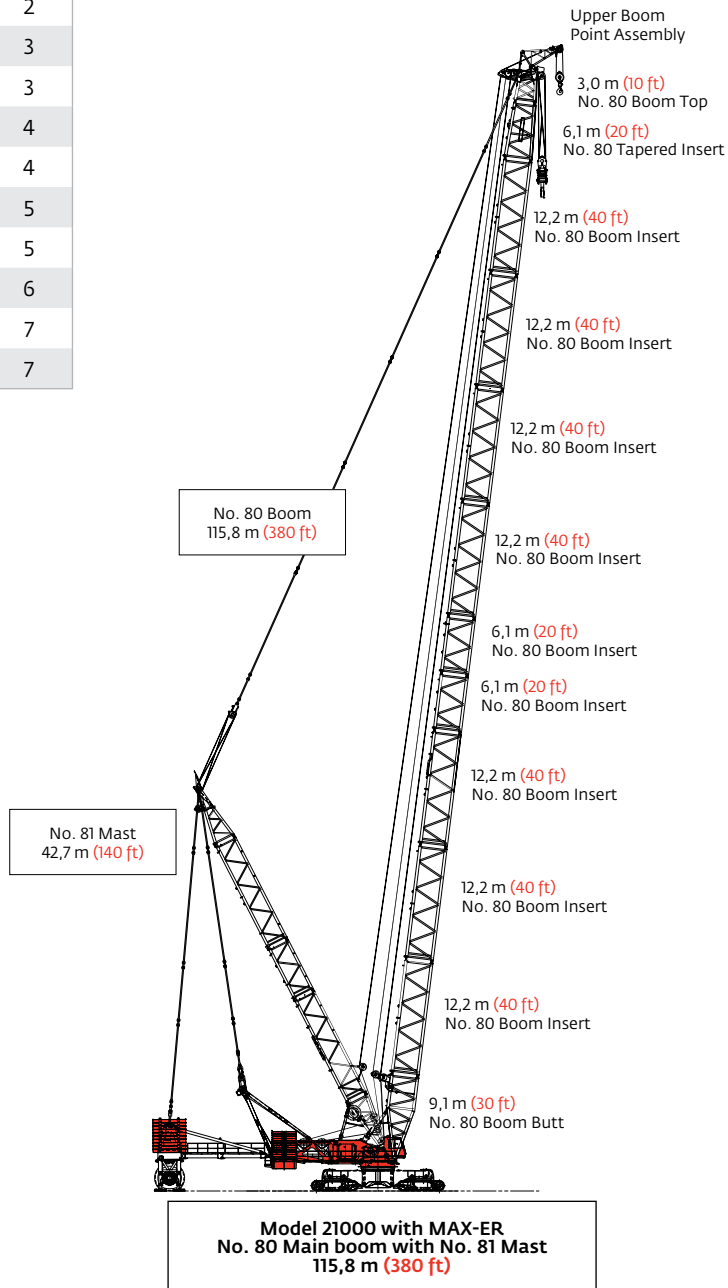

Boom combinations

No. 81 Luffing jib combinations		
Luffing jib length m (ft)	Boom inserts	
	6,1 m (20 ft)	12,2 m (40 ft)
36,6 (120)	—	—
42,7 (140)	1	—
48,8 (160)	—	1
54,9 (180)	1	1
61,0 (200)	—	2
67,1 (220)	1	2
73,2 (240)	—	3
79,2 (260)	1	3
85,3 (280)	—	4
91,4 (300)	1	4

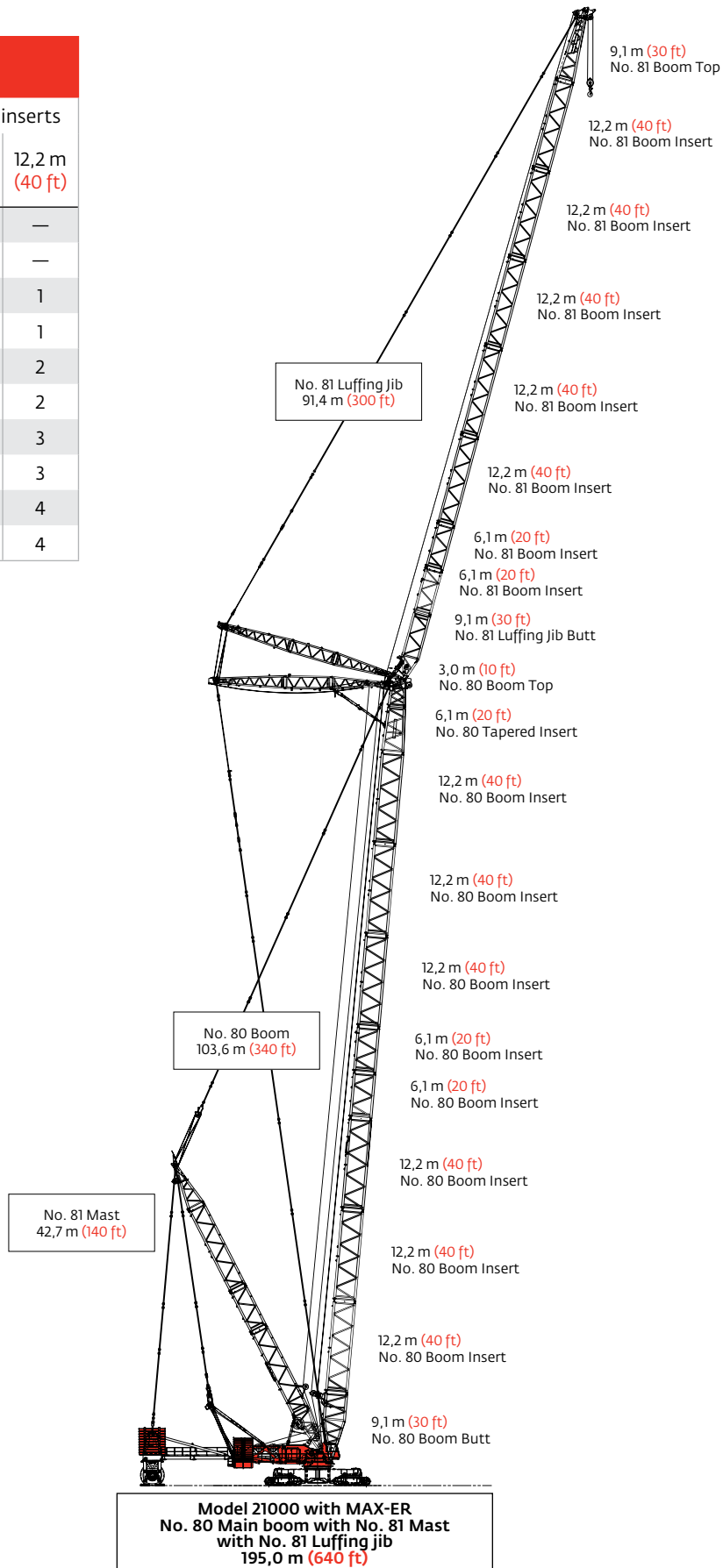

Heavy-lift boom range diagram

No. 80 Heavy-lift boom with MAX-ER®

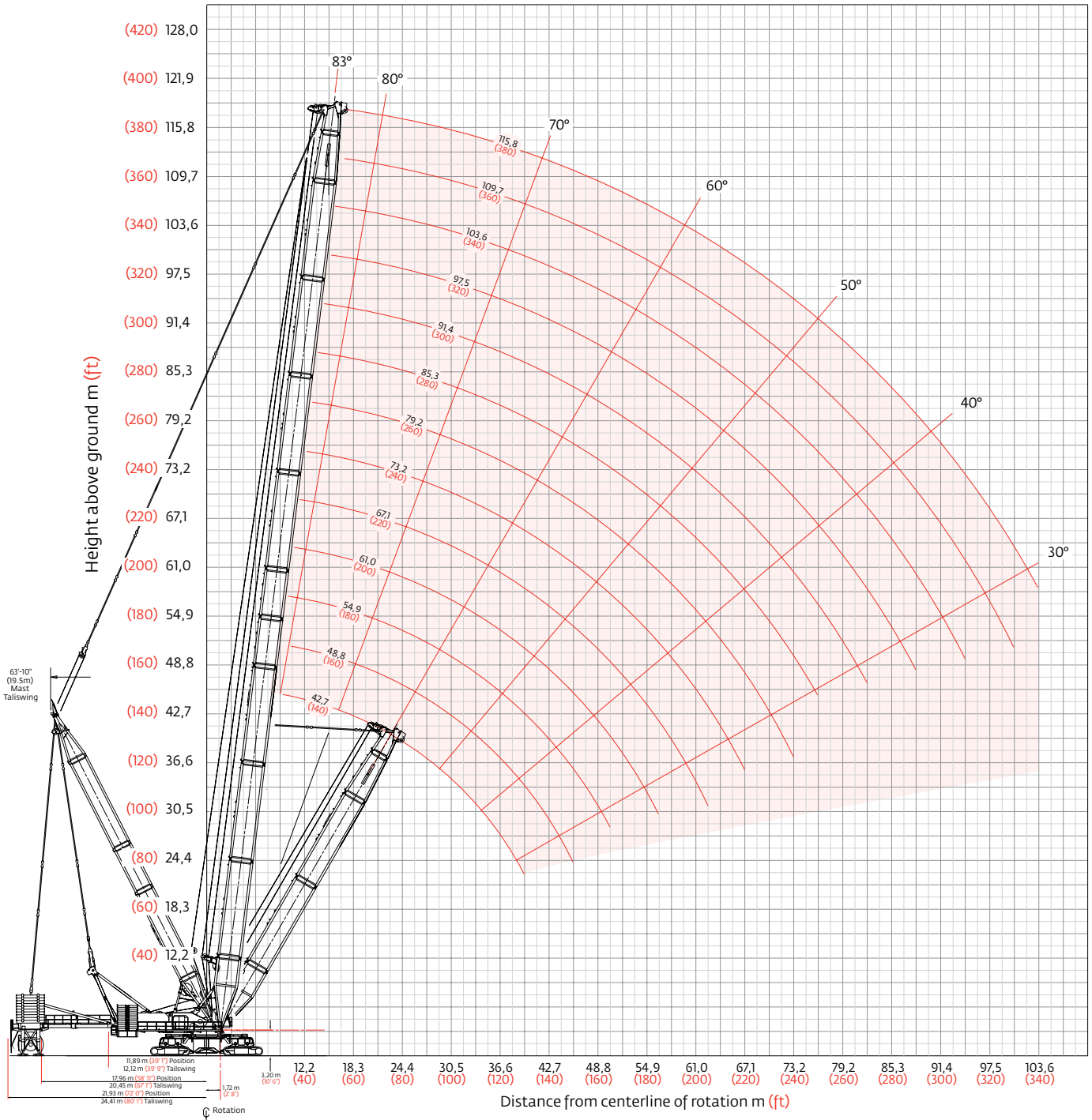

Heavy-lift boom load charts

Liftcrane boom capacities - MAX-ER®												
Boom No. 80 with 42,7 m (140') mast												
Boom m (ft) Radius	208 060 kg (458,700 lb) Counterweight 90 720 kg (200,000 lb) Carbody counterweight 511 330 kg (1,127,300 lb) Hanging counterweight 360° Rating for wide crawler arrangement or narrow crawler arrangement with outriggers kg (lb) x 1 000											
	42,7 (140)	48,8 (160)	54,9 (180)	61,0 (200)	67,0 (220)	73,2 (240)	85,3 (280)	91,4 (300)	97,5 (320)	103,6 (340)	109,7 (360)	115,8 (380)
	8,5 (28)	907,1 (2000.0)										
9,0 (32)	907,1 (2000.0)	— (2000.0)										
10,0 (36)	907,1 (2000.0)	907,1 (2000.0)	— (1941.3)	— (1863.9)								
12,0 (40)	907,1 (2000.0)	907,1 (2000.0)	880,5 (1941.3)	845,4 (1863.9)	796,7 (1756.5)	— (1641.6)						
14,0 (50)	899,7 (1911.9)	899,2 (1906.6)	877,3 (1903.0)	845,4 (1863.9)	796,2 (1753.7)	742,1 (1628.9)	618,9 (1356.3)	— (1247.8)	— (1103.8)			
18,0 (60)	734,2 (1593.4)	731,8 (1588.2)	730,3 (1584.8)	729,6 (1580.6)	731,4 (1576.3)	718,4 (1573.8)	605,3 (1332.3)	557,2 (1226.4)	500,6 (1103.8)	439,1 (968.1)	386,3 (851.7)	— (753.0)
20,0 (70)	660,2 (1362.8)	657,8 (1357.7)	656,3 (1354.3)	654,4 (1350.0)	652,4 (1345.6)	651,2 (1343.1)	598,1 (1307.8)	550,8 (1204.7)	500,6 (1103.8)	439,1 (968.1)	386,3 (851.7)	341,5 (753.0)
24,0 (80)	547,7 (1188.0)	545,5 (1183.1)	543,9 (1179.7)	541,9 (1175.3)	539,9 (1170.8)	538,7 (1168.2)	536,4 (1160.5)	529,6 (1155.7)	493,5 (1085.2)	439,1 (968.1)	386,3 (851.7)	341,5 (753.0)
26,0 (90)	504,1 (1051.0)	501,9 (1046.1)	500,3 (1042.8)	498,3 (1038.3)	496,3 (1033.7)	495,1 (1031.2)	491,6 (1023.4)	489,4 (1018.5)	486,6 (1021.7)	439,1 (968.1)	386,3 (851.7)	341,5 (753.0)
30,0 (100)	433,8 (940.6)	431,6 (935.8)	430,2 (932.6)	428,1 (928.0)	426,0 (923.4)	424,8 (920.8)	421,3 (913.0)	419,1 (908.1)	420,5 (911.4)	420,7 (906.4)	386,3 (851.7)	341,5 (753.0)
32,0 (110)	405,1 (849.7)	403,0 (845.1)	401,5 (841.9)	399,4 (837.3)	397,3 (832.6)	396,1 (830.0)	392,6 (822.2)	390,4 (817.3)	391,9 (820.6)	389,6 (815.6)	379,4 (812.0)	337,3 (727.7)
36,0 (120)	354,8 (764.4)	354,9 (769.1)	353,4 (766.0)	351,3 (761.3)	349,2 (756.6)	348,0 (754.0)	344,5 (746.2)	342,3 (741.3)	343,8 (744.6)	341,5 (739.6)	339,8 (736.0)	317,8 (694.6)
38,0 (130)	325,6 (667.0)	334,6 (704.5)	333,1 (701.4)	331,0 (696.8)	328,9 (692.1)	327,7 (689.5)	324,1 (681.6)	321,9 (676.7)	323,4 (680.0)	321,2 (675.1)	319,5 (671.4)	308,1 (661.9)
42,0 (140)		298,9 (645.7)	298,2 (645.9)	296,1 (641.3)	293,9 (636.5)	292,7 (633.9)	289,2 (626.1)	286,9 (621.2)	288,5 (624.5)	286,2 (619.5)	284,5 (615.9)	282,5 (610.9)
48,0 (160)			256,2 (554.3)	254,3 (550.5)	252,1 (545.8)	251,0 (543.3)	247,4 (535.4)	245,2 (530.5)	246,7 (533.9)	244,5 (528.9)	242,8 (525.3)	240,5 (520.2)
54,0 (180)				221,4 (478.7)	219,5 (474.8)	218,3 (472.3)	214,8 (464.5)	212,5 (459.6)	214,1 (463.0)	211,8 (458.0)	210,2 (454.4)	207,9 (449.4)
60,0 (200)					192,9 (415.5)	192,0 (415.2)	188,5 (407.5)	186,3 (402.6)	187,9 (406.1)	185,6 (401.1)	184,0 (397.5)	181,7 (392.5)
66,0 (220)						170,1 (365.0)	166,9 (360.5)	164,7 (355.7)	166,3 (359.2)	164,1 (354.3)	162,4 (350.7)	160,2 (345.7)
74,0 (240)							143,4 (321.2)	141,2 (316.4)	142,9 (320.0)	140,6 (315.1)	139,0 (311.6)	136,8 (306.6)
78,0 (260)								131,2 (282.9)	132,9 (286.7)	130,7 (281.8)	129,1 (278.3)	126,8 (273.3)
86,0 (280)									115,6 (257.9)	113,5 (253.1)	111,9 (249.6)	109,6 (244.7)
90,0 (300)										105,9 (228.0)	104,4 (224.7)	99,4 (210.2)
98,0 (320)											91,0 (202.7)	76,3 (171.3)
102,0 (340)												65,2 (133.9)

Meets ANSI B30.5 Requirements - Capacities do not exceed 75% of static tipping load.
 NOTICE: This capacity chart is for reference only and must not be used for lifting purposes.

Luffing jib range diagram

No. 81 Luffing jib on No. 80 Boom with MAX-ER®

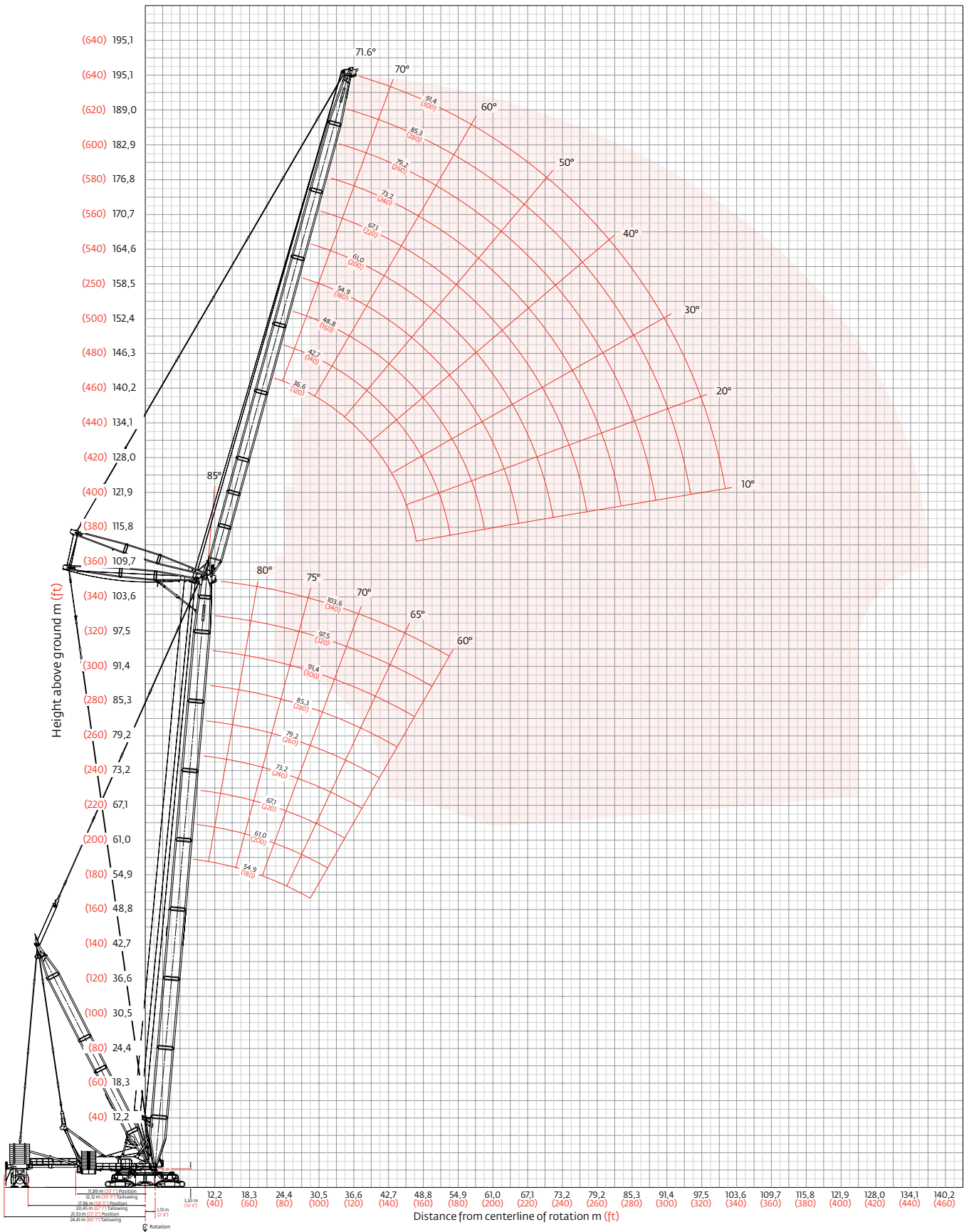

Luffing jib load charts

Liftcrane luffing jib capacities - MAX-ER® Luffing jib No. 81 on Boom No. 80

224 390 kg (497,700 lb) Counterweight 90 720 kg (200,000 lb) Carbody counterweight
509 840 kg (1,124,000 lb) Wheeled counterweight
360° Rating for wide crawler arrangement or narrow crawler arrangement with outriggers kg (lb) x 1 000
85° Boom angle

Luffing jib length	Boom m (ft) Radius	54,9 (180)	67,1 (220)	79,2 (260)	91,4 (300)	103,6 (340)
	18,3 (60)	453,5 (1000.0)				
20,0 (70)	451,1 (969.1)					
24,0 (80)	417,4 (913.3)	— (787.0)				
30,0 (100)	372,1 (812.7)	317,6 (689.8)	270,2 (585.7)	229,4 (498.5)	— (415.9)	
36,0 (120)	300,3 (647.0)	253,5 (547.1)	219,3 (474.1)	190,3 (412.0)	164,3 (356.3)	
42,0 (140)	233,8 (484.3)	205,8 (445.1)	180,4 (390.2)	158,5 (343.1)	138,7 (300.5)	
48,0 (160)						
54,0 (180)						
60,0 (200)						
64,0 (215)						

Luffing jib length	Boom m (ft) Radius	54,9 (180)	67,1 (220)	79,2 (260)	91,4 (300)	103,6 (340)
	18,3 (60)					
20,0 (70)						
24,0 (80)	339,8 (749.2)	— (622.1)				
30,0 (100)	319,5 (696.3)	265,8 (579.7)	224,1 (488.4)	187,3 (411.9)	— (317.6)	
36,0 (120)	272,6 (591.0)	227,7 (493.9)	193,8 (420.9)	165,4 (359.6)	139,9 (306.6)	
42,0 (140)	226,7 (489.4)	190,3 (411.0)	164,0 (354.5)	141,6 (306.6)	122,1 (264.7)	
48,0 (160)	187,0 (402.6)	158,0 (340.2)	137,4 (296.4)	120,0 (259.1)	104,7 (226.3)	
54,0 (180)	155,5 (334.4)	132,0 (284.1)	115,8 (249.5)	102,0 (220.0)	89,8 (193.9)	
60,0 (200)	132,9 (287.7)	113,1 (244.5)	99,7 (215.6)	88,2 (190.8)	78,1 (168.8)	
64,0 (215)			94,1 (—)	82,5 (—)	72,7 (158.1)	

Luffing jib length	Boom m (ft) Radius	54,9 (180)	67,1 (220)	79,2 (260)	91,4 (300)	103,6 (340)
	27,4 (90)	220,4 (486.1)				
30,0 (100)	220,4 (486.1)	191,0 (421.1)	— (357.5)	— (299.4)		
36,0 (120)	219,7 (483.4)	188,2 (410.2)	159,9 (349.8)	135,2 (297.6)	106,9 (235.7)	
44,0 (150)	190,9 (405.7)	161,0 (341.8)	137,9 (293.2)	118,1 (251.3)	100,6 (214.5)	
54,0 (180)	151,4 (326.7)	127,1 (274.3)	109,6 (236.7)	94,6 (204.6)	81,5 (176.3)	
64,0 (210)	118,0 (260.1)	99,0 (218.3)	85,9 (189.5)	74,8 (165.0)	65,0 (143.3)	
72,0 (240)	97,7 (210.2)	82,2 (176.8)	71,6 (154.2)	62,7 (135.1)	54,7 (118.0)	
0,0 (270)		71,4 (—)	62,2 (135.6)	54,4 (117.6)	47,5 (102.3)	
88,0 (300)						
100,0 (330)						

Luffing jib length	Boom m (ft) Radius	54,9 (180)	67,1 (220)	79,2 (260)	91,4 (300)	103,6 (340)
	27,4 (90)					
30,0 (100)						
36,0 (120)	149,6 (330.0)	130,0 (286.7)	114,1 (251.6)	97,7 (215.6)	— (177.9)	
44,0 (150)	140,9 (299.4)	130,0 (283.3)	113,0 (243.7)	96,6 (208.4)	78,4 (172.5)	
54,0 (180)	112,1 (242.2)	112,8 (244.3)	96,9 (210.4)	82,8 (179.9)	70,2 (152.6)	
64,0 (210)	87,1 (192.1)	88,9 (196.0)	80,0 (176.4)	68,5 (151.0)	58,2 (128.4)	
72,0 (240)	70,4 (150.3)	72,1 (154.3)	67,9 (146.2)	58,2 (125.3)	49,5 (106.8)	
80,0 (270)	56,0 (115.6)	57,7 (119.2)	57,6 (121.5)	49,5 (104.3)	42,1 (89.0)	
88,0 (300)	44,1 (87.5)	45,6 (90.4)	47,0 (93.6)	42,5 (88.5)	36,2 (75.5)	
100,0 (330)			33,0 (72.1)	33,8 (73.5)	30,7 (67.6)	

Meets ANSI B30.5 Requirements - Capacities do not exceed 75% of static tipping load.
NOTICE: This capacity chart is for reference only and must not be used for lifting purposes.

Luffing jib load charts

Liftcrane luffing jib capacities - MAX-ER® Luffing jib No. 81 on boom No. 80

224 390 kg (497,700 lb) Counterweight 90 720 kg (200,000 lb) Carbody counterweight
509 840 kg (1,124,000 lb) Wheeled counterweight
360° Rating for wide crawler arrangement or narrow crawler arrangement with outriggers kg (lb) x 1 000
75° Boom angle

Luffing jib length	Boom m (ft) Radius	54,9 (180)	67,1 (220)	79,2 (260)	91,4 (300)	103,6 (340)
	36,6 m (120 ft)	34,0 (110)	369,6 (826.6)			
	36,0 (120)	348,1 (754.8)	— (736.4)			
	40,0 (130)	311,4 (693.5)	303,9 (676.8)	295,9 (658.8)		
	44,0 (150)	281,1 (594.6)	274,4 (580.4)	267,1 (565.1)	— (520.2)	
	50,0 (170)	244,1 (516.7)	238,5 (505.4)	232,4 (492.4)	219,8 (469.3)	186,0 (397.8)
	56,0 (190)		209,1 —	204,4 (433.3)	196,7 (418.1)	167,1 (355.0)
	64,0 (210)					141,6 (312.3)
	72,0 (230)					
	80,0 (250)					
	— (270)					

Luffing jib length	Boom m (ft) Radius	54,9 (180)	67,1 (220)	79,2 (260)	91,4 (300)	103,6 (340)
	54,9 m (180 ft)	34,0 (110)				
	36,0 (120)					
	40,0 (130)					
	44,0 (150)	276,6 (585.2)	— (569.5)			
	50,0 (170)	240,7 (510.2)	234,1 (496.4)	225,1 (481.7)	— (415.6)	
	56,0 (190)	212,1 (450.4)	206,4 (438.2)	200,3 (425.2)	179,9 (387.2)	147,2 (317.3)
	64,0 (210)	182,1 (401.5)	177,1 (390.6)	171,9 (379.0)	161,2 (355.5)	132,2 (291.6)
	72,0 (230)	— (359.7)	153,9 (350.6)	149,4 (340.4)	142,7 (324.2)	116,6 (265.3)
	80,0 (250)			— (306.8)	124,1 (293.4)	101,5 (239.7)
	— (270)					— (214.2)

Luffing jib length	Boom m (ft) Radius	54,9 (180)	67,1 (220)	79,2 (260)	91,4 (300)	103,6 (340)
	73,2 m (240 ft)	50,0 (160)	213,7 (475.4)			
	54,0 (180)	205,6 (448.5)	196,8 (433.9)			
	60,0 (200)	188,7 (409.5)	186,0 (402.7)	171,0 (374.3)	144,4 (316.4)	
	68,0 (220)	163,6 (367.2)	160,6 (360.1)	155,3 (348.3)	134,6 (299.8)	110,2 (245.6)
	76,0 (250)	140,7 (309.2)	140,4 (308.6)	135,7 (298.3)	122,6 (269.8)	100,0 (220.0)
	84,0 (280)	121,4 (261.9)	123,8 (267.5)	119,6 (258.5)	110,4 (239.0)	89,3 (193.1)
	92,0 (310)		103,5 —	105,8 (221.3)	96,2 (201.7)	79,0 (167.4)
	100,0 (340)					68,8 —
	112,0 (370)					
	120,0 (390)					

Luffing jib length	Boom m (ft) Radius	54,9 (180)	67,1 (220)	79,2 (260)	91,4 (300)	103,6 (340)
	91,4 m (300 ft)	50,0 (160)				
	54,0 (180)					
	60,0 (200)	121,6 (262.9)	124,5 (270.7)			
	68,0 (220)	101,6 (229.3)	107,9 (242.7)	111,1 (248.7)	102,0 (225.0)	
	76,0 (250)	83,0 (182.1)	89,7 (196.9)	95,5 (209.8)	98,5 (216.4)	85,3 (187.8)
	84,0 (280)	66,7 (141.9)	72,9 (155.3)	79,1 (168.5)	84,1 (179.9)	78,9 (171.3)
	92,0 (310)	53,1 (108.8)	58,4 (120.0)	63,9 (131.5)	69,3 (143.2)	71,5 (152.6)
	100,0 (340)	41,7 (82.4)	46,2 (91.2)	50,8 (100.7)	55,8 (110.9)	60,4 (120.9)
	112,0 (370)			35,5 (76.7)	39,1 (84.3)	43,0 (92.8)
	120,0 (390)					34,1 (77.5)

Meets ANSI B30.5 Requirements - Capacities do not exceed 75% of static tipping load.
NOTICE: This capacity chart is for reference only and must not be used for lifting purposes.

Luffing jib load charts

Liftcrane luffing jib capacities - MAX-ER® Luffing jib No. 81 on boom No. 80

224 390 kg (497,700 lb) Counterweight 90 720 kg (200,000 lb) Carbody counterweight
509 840 kg (1,124,000 lb) Wheeled counterweight
360° Rating for wide crawler arrangement or narrow crawler arrangement with outriggers kg (lb) x1000
65° Boom angle

Luffing jib length 36,6 m (120 ft)	Boom m (ft) Radius	54,9 (180)	54,9 (180)	79,2 (260)	91,4 (300)	103,6 (340)
	50,0 (160)	232,1 (525.9)				
	52,0 (170)	222,2 (491.9)				
	58,0 (190)	196,4 (433.8)	188,1 (415.5)	179,1 (395.6)		
	64,0 (210)		167,7 (369.7)	159,9 (352.5)	150,9 (332.8)	
	70,0 (230)			143,4 (315.7)	135,7 (298.7)	126,7 (279.0)
	76,0 (250)				122,2 (268.6)	114,5 (251.7)
	82,0 (270)					— (226.6)
	88,0 (290)					
	94,0 (310)					
	100,0 (330)					

Luffing jib length 54,9 m (180 ft)	Boom m (ft) Radius	54,9 (180)	67,1 (220)	79,2 (260)	91,4 (300)	103,6 (340)
	50,0 (160)					
	52,0 (170)					
	58,0 (190)					
	64,0 (210)	171,3 (377.8)	162,9 (359.2)			
	70,0 (230)	154,2 (339.5)	146,6 (322.8)	138,5 (304.9)		
	76,0 (250)	139,5 (306.6)	132,7 (291.7)	125,4 (275.6)	117,3 (257.8)	
	84,0 (270)		116,7 (264.5)	110,5 (250.2)	103,3 (234.0)	95,3 (216.0)
	88,0 (290)			103,8 (227.4)	97,1 (213.0)	89,7 (196.6)
	96,0 (310)				85,5 (193.8)	79,4 (179.3)
	100,0 (330)					74,5 (162.8)

Luffing jib length 73,2 m (240 ft)	Boom m (ft) Radius	54,9 (180)	67,1 (220)	79,2 (260)	91,4 (300)	103,6 (340)
	70,0 (225)	149,2 (337.3)		—		
	74,0 (235)	139,5 (320.1)				
	80,0 (250)	126,7 (296.8)	119,6 (280.4)	112,1 —		
	88,0 (270)	112,1 (269.6)	105,8 (254.5)	99,1 (238.5)	91,7 —	
	96,0 (300)	99,6 (235.0)	94,0 (221.7)	88,0 (207.5)	81,3 (192.0)	74,1 (175.1)
	108,0 (330)		— (194.0)	73,8 (181.7)	68,3 (167.8)	62,0 (152.6)
	116,0 (360)				— (147.0)	54,1 (133.4)
	124,0 (390)					— (110.9)
	132,0 (420)					
	136,0 (450)					

Luffing jib length 91,4 m (300 ft)	Boom m (ft) Radius	54,9 (180)	67,1 (220)	79,2 (260)	91,4 (300)	103,6 (340)
	70,0 (225)					
	74,0 (235)					
	80,0 (250)	91,8 —				
	88,0 (270)	76,1 (192.5)	85,0 —			
	96,0 (300)	61,4 (153.6)	70,6 (174.1)	78,9 (188.8)		
	108,0 (330)	43,3 (119.1)	50,8 (138.1)	59,0 (157.4)	62,8 (154.7)	55,2 (131.0)
	116,0 (360)	— (90.8)	40,1 (106.6)	47,0 (124.1)	54,6 (135.0)	49,3 (119.0)
	124,0 (390)		— (81.3)	37,1 (95.3)	43,4 (111.1)	43,0 (103.7)
	132,0 (420)				34,7 (85.1)	36,3 (87.6)
	136,0 (450)					32,6 (69.3)

Meets ANSI B30.5 Requirements - Capacities do not exceed 75% of static tipping load.
NOTICE: This capacity chart is for reference only and must not be used for lifting purposes.

Manitowoc Crane Care

Crane Care is Manitowoc's comprehensive service and support program. It includes classroom and on-site training, prompt parts availability, expert field service, technical support and documentation – for every one of the more than 7,000 Manitowoc cranes currently in use throughout the world.

That's commitment you won't find anywhere else.

That's Crane Care.

Service training

Manitowoc specialists work with you in our training centers and in the field to make sure you know how to get maximum performance, reliability and life from your cranes.

Manitowoc Cranes Technical Training Centers provide valuable multi-level training, which is available for all models and attachments, in the following format:

- **Intro to Canbus and Canbus 1, 2, 3**
- **Intro to EPIC and EPIC 1, 2, 3**
- **Small Crawler 1**
- **Canbus 1 and 2 assembly, operation and maintenance**
- **EPIC 1 and 2 assembly, operation and maintenance**

Refer to www.manitowoc.com for course descriptions.

Parts availability

Genuine Manitowoc replacement parts are accessible through your distributor 24 hours a day, 7 days a week, 365 days a year.

Service interval kits

200 hour kit

1,000 hour kit

2,000 hour kit

Hydraulic test kit

U.S. standard tools kit

Field service

Factory-trained service experts are always ready to help maintain your crane's peak performance.

For a worldwide listing of dealer locations, please consult our website at: www.manitowoc.com

Technical support

Manitowoc's dealer network and factory personnel are available 24 hours a day, 7 days a week, 365 days a year to answer your technical questions and more,

with the help of computerized programs that simplify crane selection, lift planning, and ground-bearing calculations.

For a worldwide listing of dealer locations, please consult our website at: www.manitowoc.com

Technical documentation

Manitowoc has the industry's most extensive documentation; available in major languages and formats that include print, videotape, and DVD/CD.

Additional copies available through your Authorized Manitowoc Distributor.

- Crane operator's manual
- Crane parts manual
- Crane capacity manual
- Crane vendor manual
- Crane service manual
- Luffing jib operator's/parts manual
- Capacity chart manual - attachments

CD rom versions of the operator's and parts manuals are shipped with each crane. Also available are the following CDs:

- Crane Care Owner CD –
- Ground Bearing Pressure Estimator CD
- Crane Selection and Planning Software (CompuCRANE®)
- EPIC® Crane Library CD consisting of capacity charts, range diagrams, wire rope specifications, travel specifications, crane weights, counterweight arrangements, luffing jib raising procedures, operating range diagrams, drum and lagging charts, boom rigging drawings, jib rigging drawings, outline dimensions and wind condition charts.

Available from your Authorized Manitowoc Cranes Distributor, these videos are available in NTSC, PAL, SECAM, and DVD formats.

- Your Capacity Chart Video
- Respect the Limits Video
- Crane Safety Video
- Boom Inspection/Repair Video

Crane Care Package

Manitowoc has assembled all of the available literature, CD's and videos listed above plus several Manitowoc premiums into one complete Crane Care Package.

Regional headquarters

Manitowoc - Americas

Manitowoc, Wisconsin, USA

Tel: +1 920 684 6621

Fax: +1 920 683 6277

Shady Grove, Pennsylvania, USA

Tel: +1 717 597 8121

Fax: +1 717 597 4062

Manitowoc - Europe, Middle East & Africa

Ecully, France

Tel: +33 (0)4 72 18 20 20

Fax: +33 (0)4 72 18 20 00

Manitowoc - Asia Pacific

Shanghai, China

Tel: +86 21 6457 0066

Fax: +86 21 6457 4955

Regional offices

Americas

Brazil

Alphaville

Mexico

Monterrey

Chile

Santiago

Europe, Middle East & Africa

Algeria

Hydra

Czech Republic

Netvorice

France

Baudemont

Cergy

Decines

Germany

Langenfeld

Hungary

Budapest

Italy

Parabiago

Netherlands

Breda

Poland

Warsaw

Portugal

Baltar

Lisbon

Russia

Moscow

U.A.E.

Dubai

U.K.

Gawcott

Asia - Pacific

Australia

Brisbane

Melbourne

Sydney

China

Beijing

Xi'an

India

Hyderabad

Pune

Korea

Seoul

Philippines

Makati City

Singapore

Factories

Brazil

Alphaville

China

TaiAn

Zhangjiagang

France

Charlieu

La Clayette

Moulins

Germany

Wilhelmshaven

India

Pune

Italy

Niella Tanaro

Portugal

Baltar

Fânzeres

Slovakia

Saris

USA

Manitowoc

Port Washington

Shady Grove

This document is non-contractual. Constant improvement and engineering progress make it necessary that we reserve the right to make specification, equipment, and price changes without notice. Illustrations shown may include optional equipment and accessories and may not include all standard equipment.