

# SANY

Quality Changes the World

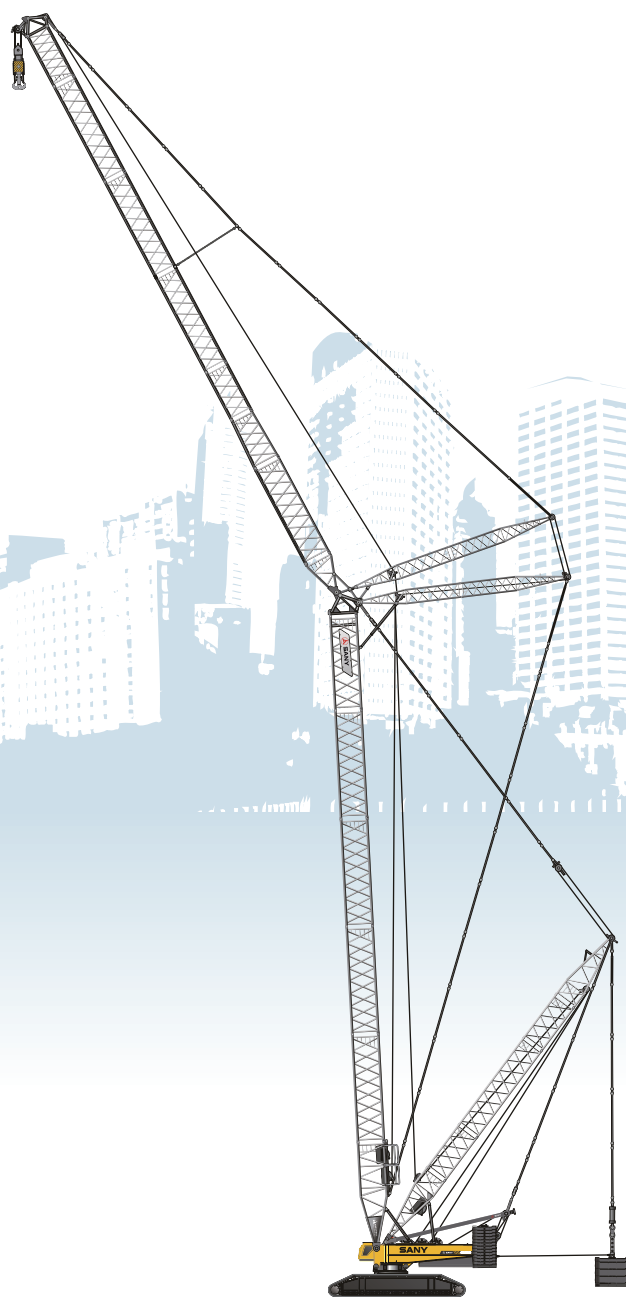

## SANY CRAWLER CRANE SCC 10000

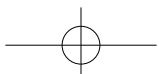

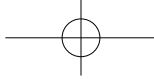

# CRAWLER CRANE

## CONTENT

---

### P3

#### SCC10000 Crawler Crane

- Outline Dimensions
- Main Technical Features
- Table of Main Performance Data
- Transport Dimensions

### P15

#### Specifications

- Superworks
- Lowerworks
- Operation Device
- Safety Devices

### P24

#### Operating Condition Combination

- Operating Condition Combination
- H Operating Condition
- HDB Operating Condition
- LJ Operating Condition
- LJ(DB) Operating Condition
- HJ Operating Condition
- HJDB Operating Condition
- SF<sub>H</sub>DB Operating Condition
- SF<sub>L</sub>DB Operating Condition

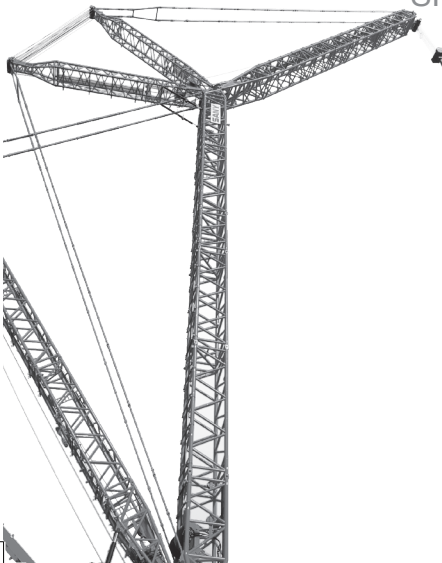

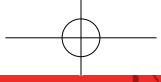

# SCC10000

04	Outline Dimensions
06	Main Technical Features
07	Table of Main Performance Data
09	Transport Dimensions



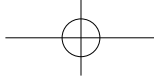

# OUTLINE DIMENSIONS

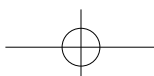
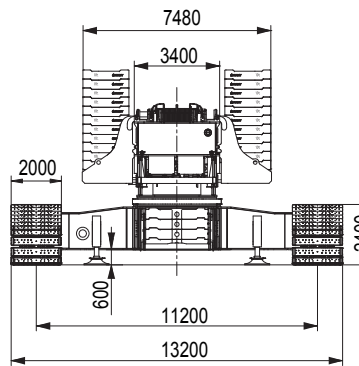
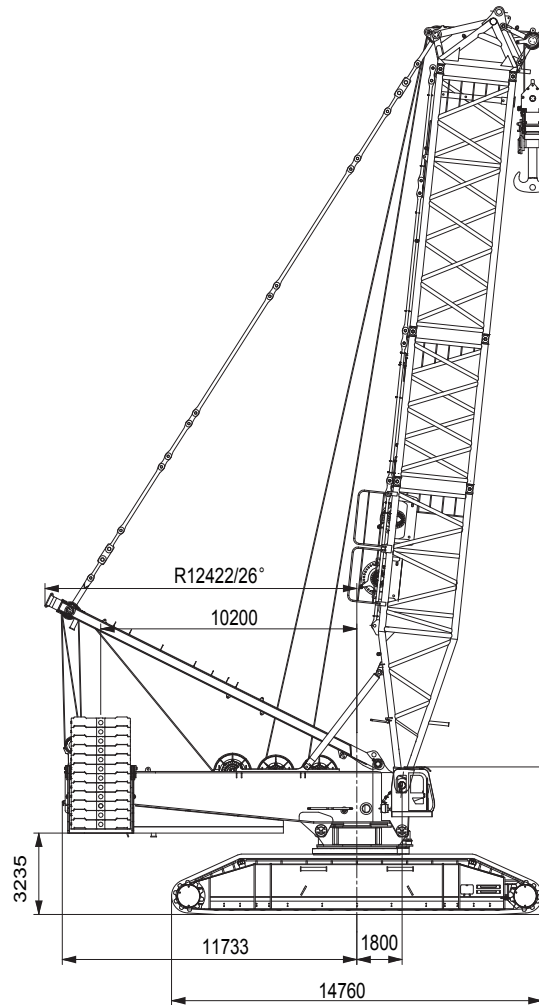

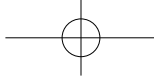

# OUTLINE DIMENSIONS

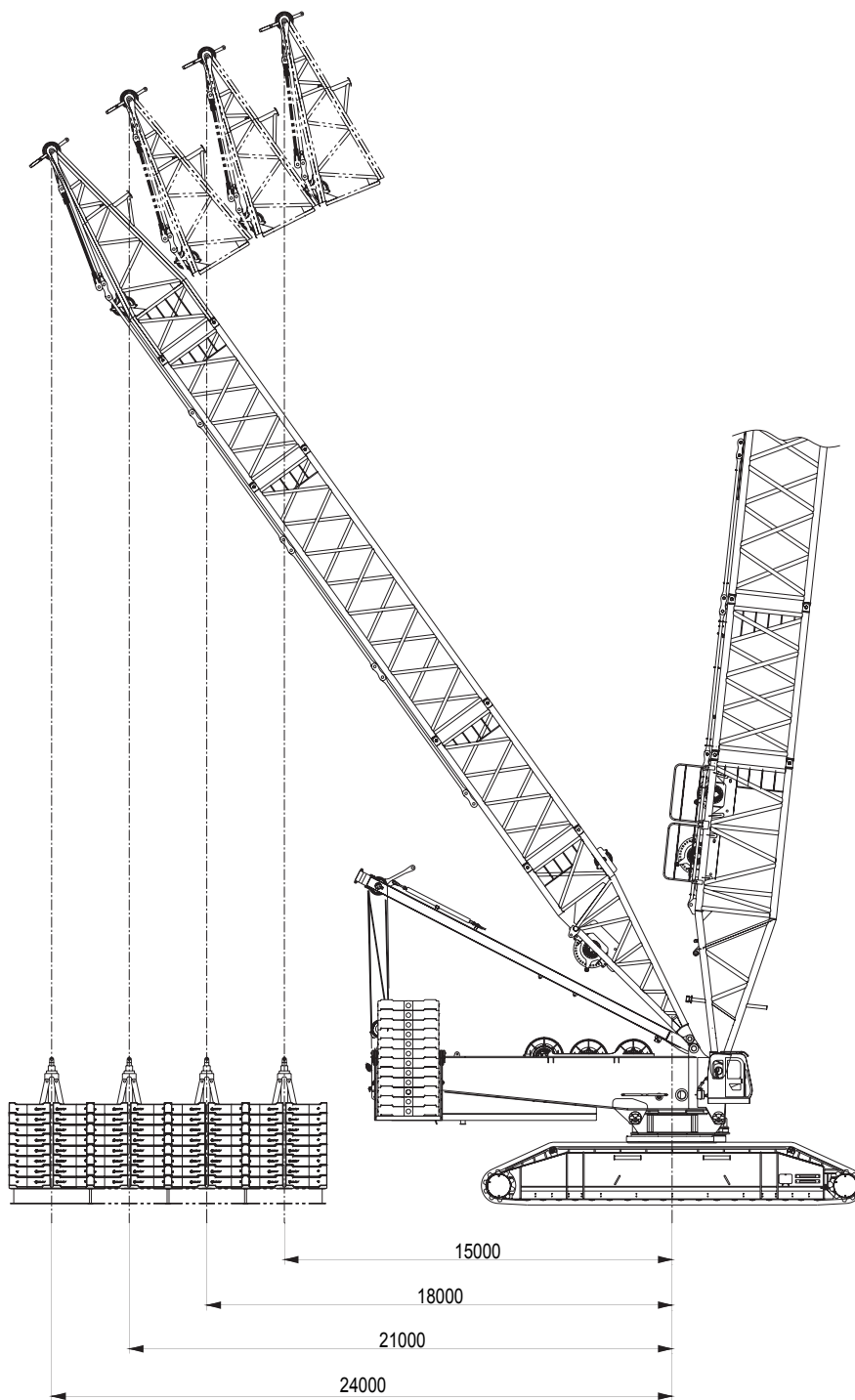

# MAIN TECHNICAL FEATURES

## 1. Safe control system:

The two operating modes of working and installation are convenient and reliable; the crane is equipped with the functions of real-time display of ground pressure and levelness, off-line stop action, emergency electric control, lightning protection, automatic traveling direction adjustment, CCTV monitoring, etc., and the safety and monitoring devices are complete;

## 2. Outstanding operating performance:

Load sensing, limit load adjustment and electro-hydraulic proportion dead slow control offer the perfect inching performance of actions, and more stable operation;

## 3. Reliable function assurance:

The key components are all of world-renowned brands; the designed safety margin of structures and members are sufficient; the control system can operate stably under the harsh environments like extreme cold, high temperature, plateau or sand wind;

## 4. Convenient maintenance technology:

It takes approximately no more than 10min/person to adjust;no more than 30min/person for daily maintenance;no more than 2h/ person to repair.GPS remote monitoring system is optional for maintenance and management;

## 5. Modularized combination:

Fast assembly and disassembly solve the troubles in transportation of oversized or overweight members;

## 6. Many operation modes:

Suitable for the constructions of wind power, fire power, petrochemical, bridges and large venues, etc.;

## 7. Optimized chassis design:

It makes the stability of the machine much better, and the ground pressure much smaller;

## 8. 100% load travel:

Powerful tracking force and travel smoothness bring the advantages of crawler crane into full play;

## 9. Independent electric control software:

All operations are controlled with computer, and the system is simple and thus more convenient to maintain; it has a friendly human-machine interface and failure self-diagnosis function with high reliability;

## 10. All-enclosed hydraulic system:

energy-conserving, efficient, and high inching features;

## 11. Centralized lubrication:

A centralized lubrication system under auto-control provides automatic lubrication to the whole truck and reduces servicing time and maintenance frequency;

## 12. Hoisting simulation software:

facilitate the users to select operating conditions and simulate operating conditions, thus to improve the working efficiency;

## 13. Base with outriggers:

easy and quick to assemble and disassemble;

## 14. Load moment limiter system:

the signal is transmitted by bus, which has a strong interference resistance.

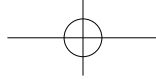

## TABLE OF MAIN PERFORMANCE DATA

Main performance data of SCC10000 crawler crane			
Performance index		Unit	Data
Boom operating condition	Max. rated lifting capacity	t	727
	Max. rated lifting moment	t·m	653×8
	Boom length	m	30~90
	Boom luffing angle	°	30~85
Operating condition of boom with superlift	Max. rated lifting capacity	t	1000
	Max. rated lifting moment	t·m	14000
	Boom length	m	42~120
	Length of superlift mast	m	42
Operating condition of luffing jib	Operating angle of boom	°	30~85
	Max. rated lifting capacity	t	349
	Boom length	m	42~60
	Jib length	m	30~96
	Fully extended boom + fully extended jib	m	(48+96)(54+84)(60+48)
	Operating angle of boom	°	65~87(65° 75° 85° 87° )
Operating condition of luffing jib with superlift	Operating angle of jib	°	20~77
	Max. rated lifting capacity	t	463
	Boom length	m	42~96
	Jib length	m	30~96
	Fully extended boom + fully extended jib	m	(96+96)
	Length of superlift mast	m	42
Operating condition of heavy-duty short fixed jib	Operating angle of boom	°	65~87(65° 70° 75° 80° 85° 87° )
	Operating angle of jib	°	20~77
	Max. rated lifting capacity	t	618
	Boom length	m	42~60
Operating condition of light-duty short fixed jib	Jib length	m	18
	Operating angle of boom	°	30~85
	Max. rated lifting capacity	t	463
Operating condition of light-duty short fixed jib	Boom length	m	42~96
	Jib length	m	18
	Operating angle of boom	°	30~85

## TABLE OF MAIN PERFORMANCE DATA

Main performance data of SCC10000 crawler crane			
Performance index		Unit	Data
Speed data	Rope speed of main winch	m/min	0~110
	Rope speed of auxiliary winch	m/min	0~110
	Rope speed of main luffing winch	m/min	(0~60)×2
	Rope speed of auxiliary luffing winch	m/min	0~110
	Rope speed of superlift luffing winch	m/min	0~110
	Swing speed	rpm	0~0.45/0~1.0
Engine	Travel speed	km/h	0~0.4/0~1.1
	Rated output power	kW	597
	Rated speed	rpm	2100
	Volume of fuel tank	L	1200
Transportation parameter	Crane weight (basic arm)	t	760
	Rear counterweight + central counterweight + superlift counterweight	t	250+80+450
	Maximum transport weight of single piece	t	60
	Maximum transport dimensions (length X width X height)	mm	13930×3400×3130
	Ground pressure (basic arm)	MPa	0.165



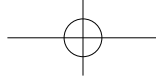

# TRANSPORT DIMENSIONS

<b>Base assembly</b>	<b>×1</b>
Length	5.95m
Width	3.54m
Height	3.03m
Weight	47000 kg
<b>Crawler frame assembly</b>	<b>×2</b>
Length	14.60m
Width	1.75m
Height	2.11m
Weight	41300 kg
<b>Crawler shoe assembly</b>	<b>×2</b>
Length	10.54m
Width	2m
Height	3×0.24m
Weight	3×13100 kg
<b>Beam</b>	<b>×2</b>
Length	10.34m
Width	2.1m
Height	1.85m
Weight	21530 kg
<b>Platform assembly</b>	<b>×1</b>
Length	13.93m
Width	3.4m
Height	3.12m
Weight	60000 kg
<b>1000t boom head</b>	<b>×1</b>
Length	4.02m
Width	3.57m
Height	2.86m
Weight	9245 kg
<b>600t boom head</b>	<b>×1</b>
Length	3.91m
Width	3.57m
Height	2.46m
Weight	5600 kg

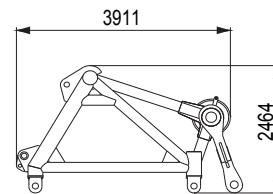
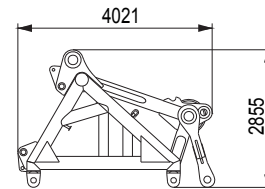
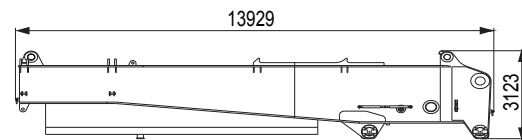
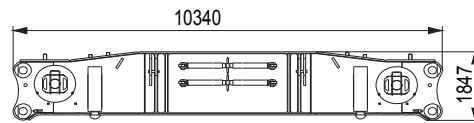
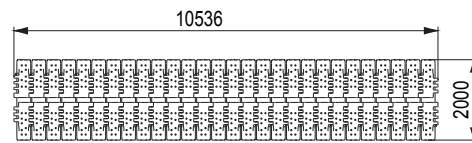
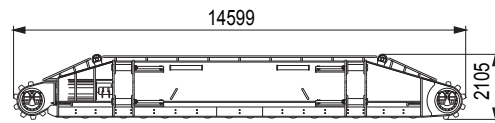
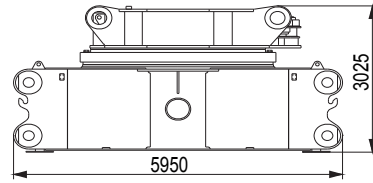

# TRANSPORT DIMENSIONS

<b>Boom base</b>	×1
Length	12.46m
Width	3.58m
Height	3.18m(including 3.43mpull rod)
Weight	18200 kg (excluding reel) 38500 kg (including reel)
<b>6m boom insert</b>	×2
Length	6.29m
Width	3.58m
Height	3.18m (including 3.46mpull rod)
Weight	6946 kg
<b>12m-A boom insert</b>	×1
Length	12.29m
Width	3.58m
Height	3.18m (including 3.46mpull rod)
Weight	14440 kg
<b>12m-B boom insert</b>	×7
Length	12.29m
Width	3.58m
Height	3.18m (including 3.46mpull rod)
Weight	12460 kg
<b>Boom tip</b>	×1
Length	10.79m
Width	3.58m
Height	3.18m (including 3.46mpull rod)
Weight	11115 kg
<b>Boom extension</b>	×1
Length	2.94m
Width	1.25m
Height	1.12m
Weight	700 kg
<b>Big pulley assembly</b>	×2
Length	1.84m
Width	1.84m
Height	1.67m
Weight	2520 kg

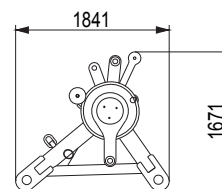
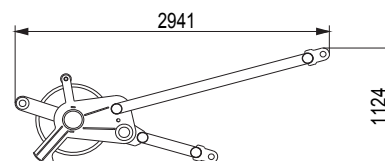
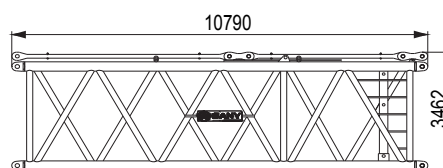
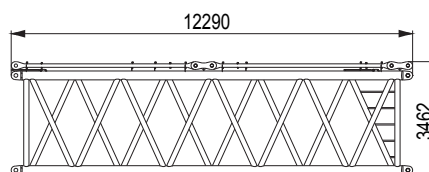
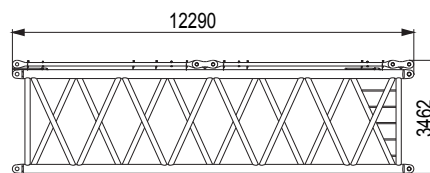
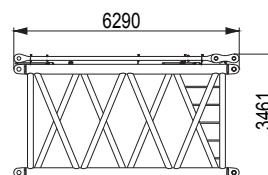
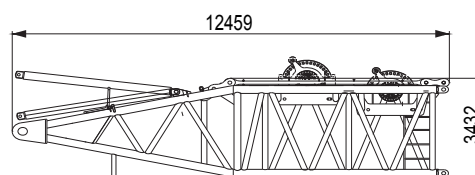

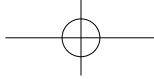

# TRANSPORT DIMENSIONS

<b>Luffing jib base</b>	<b>×1</b>
Length	5.60m
Width	3.58m
Height	3.17m
Weight	7825 kg
<b>6m luffing jib insert</b>	<b>×3</b>
Length	6.26m
Width	2.81m
Height	2.85m
Weight	4556 kg
<b>Luffing jib reducing boom</b>	<b>×1</b>
Length	6.29m
Width	3.58m
Height	3.31m
Weight	5273 kg
<b>12m luffing jib insert</b>	<b>×6</b>
Length	12.28m
Width	2.81m
Height	2.83m
Weight	8350 kg
<b>Luffing jib tip</b>	<b>×1</b>
Length	8.44m
Width	2.8m
Height	3.42m
Weight	8926 kg
<b>Trolley</b>	<b>×1</b>
Length	3.71m
Width	3.02m
Height	1.88m
Weight	1410 kg
<b>Front and rear mast tip of luffing jib</b>	<b>×1</b>
Length	12.51m
Width	1.98m
Height	3.79m
Weight	14400 kg

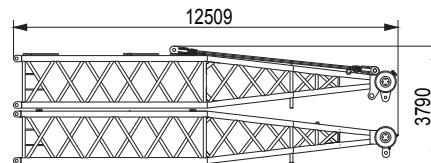
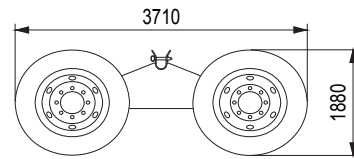
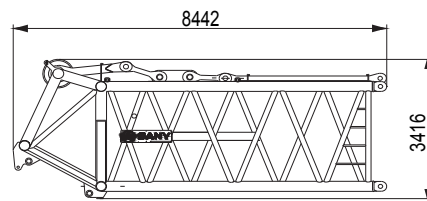
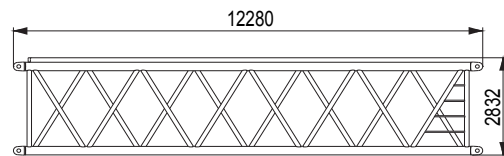
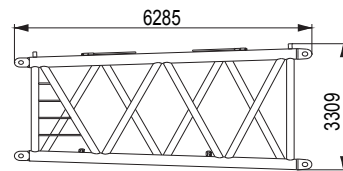
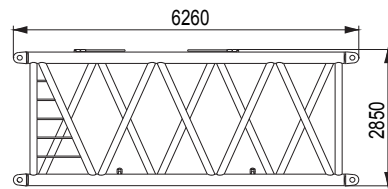
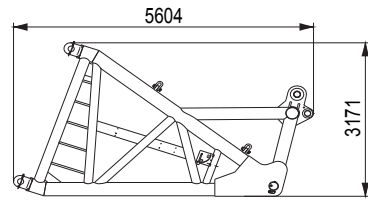

# TRANSPORT DIMENSIONS

<b>Front and rear mast base of luffing jib</b>	×1
Length	12.03m
Width	1.97m
Height	3.56m
Weight	10600 kg
<b>Superlift mast base+superlift winch</b>	×1
Length	9.31m
Width	3.49m
Height	2.9m(including 3.29m of reel)
Weight	8,827 kg (excluding reel) 20,368 kg (including reel)
<b>6m superlift mast insert</b>	×2
Length	6.26m
Width	2.81m
Height	2.85m
Weight	4556 kg
<b>12m superlift mast insert</b>	×1
Length	12.28m
Width	2.81m
Height	2.83m
Weight	8350 kg
<b>Superlift mast tip</b>	×1
Length	9.49m
Width	3.06m
Height	3.24m
Weight	15878 kg
<b>Main luffing mast+main luffing reel</b>	×1
Length	14.94m
Width	3.02m
Height	1.68m
Weight	26444
<b>Central counterweight block</b>	×8
Length	3.1m
Width	1.1m
Height	0.51m
Weight	10000 kg

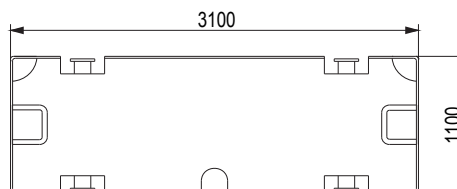
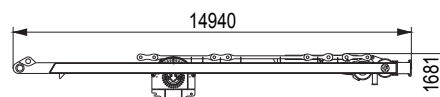
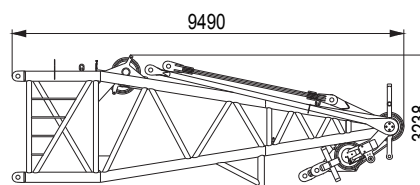
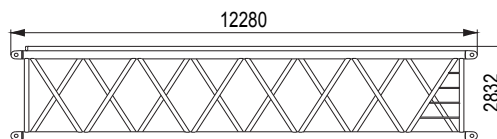
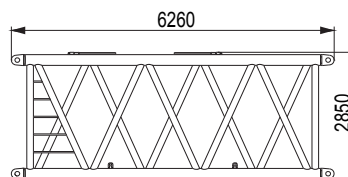
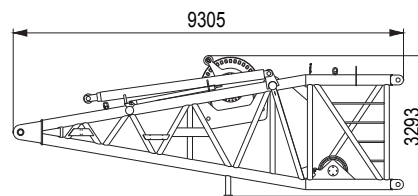
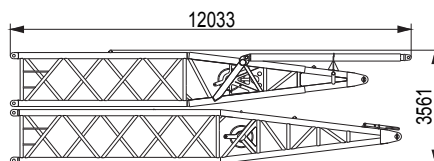

# TRANSPORT DIMENSIONS

<b>Central counterweight frame</b>	<b>×2</b>
Length	3.84m
Width	1.42m
Height	1.72m
Weight	2207 kg
<b>Rear counterweight tray of machine</b>	<b>×2</b>
Length	2.7m
Width	2.27m
Height	2.68m
Weight	6086 kg
<b>10t counterweight block</b>	<b>×66</b>
Length	2.35m
Width	1.84m
Height	0.45m
Weight	10000kg
<b>Superlift counterweight frame</b>	<b>×1</b>
Length	8.48m
Width	3.42m
Height	0.99m
Weight	10700 kg (including 28215kg iron ingot)
<b>20t hook block</b>	<b>×1</b>
Length	1.34m
Width	0.72m
Height	0.72m
Weight	1700 kg
<b>50t lifting hook</b>	<b>×1</b>
Length	2.2m
Width	0.84m
Height	0.67m
Weight	3410 kg
<b>100t lifting hook</b>	<b>×1</b>
Length	2.3m
Width	0.84m
Height	0.9m
Weight	4930 kg

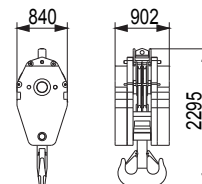
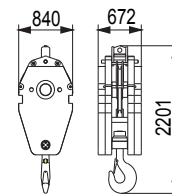
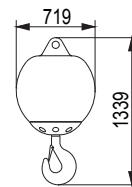
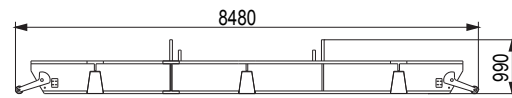
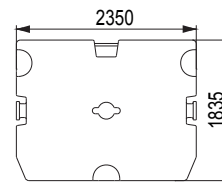
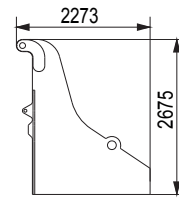
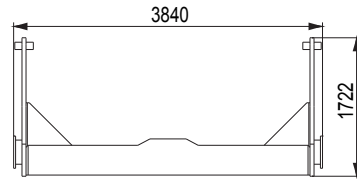

## TRANSPORT DIMENSIONS

<b>1000t lifting hook</b>	×1
Length	4.5m
Width	4m
Height	1.25m
Weight	22797 kg
Note: it can be disassembled into the 500t lifting hooks.	
<b>Main hoisting winch mechanism</b>	×2
Length	2.28m
Width	1.62m
Height	1.56m
Weight	12851 kg
<b>Auxiliary hoisting winch mechanism</b>	×1
Length	2.01m
Width	1.62m
Height	1.63m
Weight	9033 kg
<b>Mobile pumping station</b>	×1
Length	1.36m
Width	0.87m
Height	0.98m
Weight	200 kg
<b>Cab</b>	×1
Length	2.47m
Width	1.68m
Height	2.26m
Weight	1200 kg

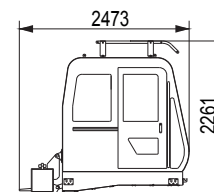
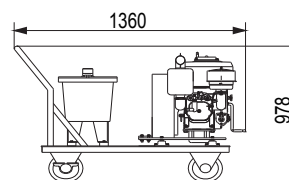
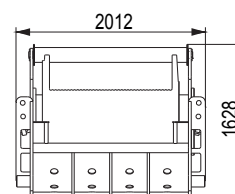
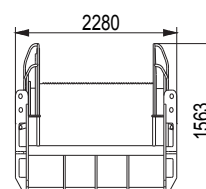
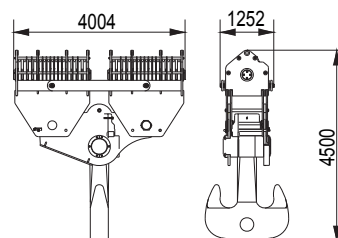

Notes: 1.The transport dimensions of the parts are marked on schematic diagrams, but not drawn by scale; the dimensions indicated are the design values excluding package.

2.The weight is the design value and there may be tiny difference due to the manufacturing calibration.

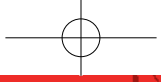

# SCC10000

16	Superworks
18	Lowerworks
19	Operation Device
21	Safety Devices

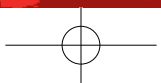

# SUPERWORKS

## 1) Engine

- Six-cylinder and water-cooled engine QSK23 of a famous manufacturer runs at the rated power 597kW, rated speed 2100rpm. The maximum output torque is 3,308N·m, and maximum output torque speed 1400 rpm.
- It is equipped with a diesel fuel tank with a volume up to 12000L.

## 2) Electric Control System

The system uses imported RC controller, encoder, load moment limiter, display, intelligent sensor and CCTV monitoring system. CAN buses are used among the controller, display, operating handle, encoder, engine and load moment limiter for data transmission, improving the system reliability.

## 3) Hydraulic System

- The hydraulic system includes: hoisting hydraulic system, traveling hydraulic system, slewing hydraulic system, luffing hydraulic system, servo hydraulic system, backstop hydraulic system, cooling system, and auxiliary hydraulic system, etc. The hydraulic elements are mainly imported.
- Characteristics: The main system entirely adopts the closed circuit and is energy-conserving, efficient, and highly controllable; the starting, stopping and reversing are stable with no shock, fast response to operation, little heat generated, and long life. Electric proportion control elements are widely used to facilitate precise and smart control. Many pressure alarms and filter element blocking alarms are set in the hydraulic system to improve the reliability of hydraulic system; in order to prevent the risks caused by the bursting of closed circuit, in addition to automatic response of electric control system, a tube anti-explosion valve is set in the tube so as to further improve safety.

## 4) Main and Auxiliary Hoisting Mechanisms

Each winch uses two sets of imported variable displacement motors to drive the two sets of planet gear reducers to control the lifting and dropping of the main and auxiliary winches; the winches boasts a powerful storage capacity and higher safety. The speed of winch can be adjusted in a stepless way as required by the user, and the user may set the maximum speed within the range of 0-110m/min, with the maximum speed being 110m/min; it has a superior dead slow speed property; the fastest gear can realize quick power lift. One winch can be used for hoisting the weight below 450t and two winches are required for hoisting more than 450t; the main and auxiliary winches have the function of synchronization; the maximum multiplying Factor is 48. With wire ropes of famous brands, the polyline reel can realize smooth multi-layer winding, and the reducer is built-in to save space, thus boasting low noise, high efficiency, and long life.

### NO.1 Main lifting mechanism

Main drum diameter	700mm
Rope speed of the outermost working layer	0~110m/min
Wire rope diameter	32mm
Wire rope length of main winch	1590m
Rated single rope tension	22.6t

### NO.2 Auxiliary hoisting mechanism

Drum diameter	700mm
Rope speed of the outermost working layer	0~110m/min
Wire rope diameter	32mm
Wire rope length of auxiliary winch	875m
Rated single rope tension	22.6t

## 5) Swing Mechanism

- Slewing part: With four motor reducer drives, the slewing is smooth at the speeds of 0-1.0r/min and 0-0.45r/min; it has the function of neutral free slipping and can provide 360° slewing.
- Slewing ring: Triple-row roller slewing ring



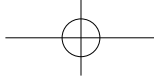

## 6) Luffing Mechanism

- Including: main luffing mechanism, auxiliary luffing mechanism, and superlift luffing mechanism; Each winch uses two sets of imported variable displacement motors to drive the two sets of planet gear reducers to control the lifting and dropping of the main and auxiliary winches; the winches boasts a powerful storage capacity and higher safety.
- With polyline reel, built-in reducer, imported wire rope, and closed circuit, it provides power through the switchover of changeover valve; and it may realize many composite actions. Stepless speed adjustment, with good dead slow speed property.

### NO.3 Main luffing mechanism

Drum diameter	780mm
Rope speed of the outermost working layer	(0~60)×2m/min
Wire rope diameter	32mm
Wire rope length of main luffing	985m
Rated single rope tension	2×22.6t

### NO.4 Auxiliary luffing mechanism

Drum diameter	700mm
Rope speed of the outermost working layer	0~110m/min
Wire rope diameter	32mm
Wire rope length of auxiliary luffing	1175m
Rated single rope tension	22.6t

### NO.5 Superlift luffing mechanism

Drum diameter	700mm
Rope speed of the outermost working layer	0~110m/min
Wire rope diameter	32mm
Wire rope length of superlift luffing	1490m
Rated single rope tension	22.6t

## 7) Counterweight

- Machine central counterweight: 80t, 8 counterweight blocks, 2 trays.
- Machine rear counterweight: 250t, 24 counterweight blocks, 2 trays.
- Superlift counterweight: 430t, 42 counterweight blocks, 1 trays.

## 8) Cab

- The cab is of an all-enclosed steel frame structure; reinforced glass is installed at the front and back; GE structural plates are installed on the top, providing good light transmission, high-strength and high abrasion resistance, and low indoor noise (below 85dB), and inside the cab are installed the control device, detection instruments, fire extinguisher and alarm device, and CCTV monitoring system, etc. It complies with ergonomic design.
- The driver's cab can be adjusted according to the requirements of work, i.e., it can be pitched upward or downward by 20° .
- The suspended structure is used and disassembly is required during transportation; and fast joints are used for hydraulic and electric connections to facilitate disassembly and transportation.

## 9) Control Operation

The display of load moment limiter, CCTV monitor, control system display and instrument are within the direct field of vision of operators; the load moment display mainly monitors the moments of crane and other parameters; the monitoring display mainly displays the operating conditions of crane, control parameters of various monitoring points and the alarm; the left and right armrest boxes have three operating handles in total, and the handle control function is switched through the handle key; independent actions and the allowed composite actions are displayed in the form of text and graph.

## 10) Alarm Display

When an alarm appears, corresponding alarm information will be indicated on the display in the forms of code and text.

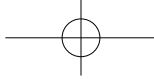

## LOWERWORKS

### 1) Traveling Drive

The traveling system has two gearshifts; the four sets of traveling drives provide strong traction force and it can realize 100% linear traveling under load and 70% steering traveling under load; each traveling device is independently driven, and may flexibly perform forward, backward or in-situ steering.

### 2) Travel Brake

The travel brake is normally engaged in the reducer (namely, it is in the braking state when the travel handle is not operated). It can compensate automatically without requiring adjustment. When the travel handle is operated, the brake will be released automatically to realize traveling.

### 3) Crawler Shoe

The crawler units at the left and right have 168 crawler shoes totally, each 2,000mm wide. The density of crawler shoe can be adjusted through the hydraulic cylinder in the crawler travel unit, and an ideal density can be achieved through adjusting the position of adjusting gasket.

### 4) Beam

High-strength welded frame structure, connected with crawler frame and base with power pin driven by the hydraulic cylinder, is easy for assembling and disassembling.

### 5) Base

High-strength welded frame structure, connected with beam with power pin driven by hydraulic cylinder, is easy for assembling and disassembling.

### 6) Travel speed

The variable displacement motor can realize two speeds, achieving infinite variable speed in each gear. High speed: 0~1.0km/h, low speed 0~0.4km/h. It may ensure smooth operation of equipment and realize fast traveling.

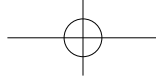

# OPERATION DEVICE

All tubes of the operation device are high-strength tubes, and the plates high-strength steel plates. The luffing bearing is also made of high-strength steel tubes. Pulley materials: the pulleys on arm lever are all the cast iron pulleys, and those on hooks are all nodular cast iron pulleys.

## 1) Boom

- The arm support is the spatial truss structure with uniform section in the middle and variable section at both ends, it is welded by steel tubes, the top and root segment of arm support are reinforced with steel plates, which is favorable to transmit load bearing forces.
- The length of boom ranges between the basic boom (30m) and the maximum length (120m).
- Composition: base 12m, insert 6m×2, insert 12m×6, insert 12m×1 (thick arm), tip 10.5m, 1000t arm head 1.5m (600t arm head 1.5m).

## 2) Main Luffing Mast

Integrally a door-shaped strut, it is welded with high-strength steel plate, extending 13.7m long, and the middle part has two beams for reinforcement. The structural strength is high with good rigidity.

## 3) Luffing Jib

- The arm support is the truss structure with uniform section in the middle and variable sections at both ends. It is welded with steel tubes, and the top and root segment of arm support are reinforced with steel plates, thus facilitating the transmission of carried load.
- The basic jib is 30m long (base 4.5m, reducing arm 6m, and insert 12m (large section), tip 7.5m), insert 6m×1, insert 12m×5; and the jib available is 30m~96m long and it can be installed on the boom of 42m~96m long.
- The jib luffing depends on the front mast and rear mast of luffing jib; the spatial truss structure has variable sections at both ends and uniform section in the middle of the mast. The front mast of luffing jib is 23.5m long, and the rear mast of luffing jib is 22.5m long.

#### 4) Lifting Hook

- Standard configuration: 20t lifting hook;  
100t lifting hook;  
250t lifting hook;  
1,000t lifting hook (which can be disassembled into 500t lifting hooks)
- The 50t lifting hooks are optional.

Hook name	Max. hoisting capacity (t)	Number of pulleys	Multiplying Factor	Weight of single piece (t)
50t lifting hook	50	1	1×3	3.4
100t lifting hook	100	2	1×5	5
250t lifting hook	250	8	1×16 2×8	9.5
500t lifting hook	500	15	1×28 2×14	18.5
1,000t lifting hook	1000	30	2×28	23.8

#### 5) Superlift Mast

- The arm support of mast is the spatial truss structure with variable section at both ends and uniform section in the middle. It is welded with steel tubes, and the top and root segments of arm support are reinforced with steel plates, thus facilitating the transmission of carried load.
- Length of superlift mast 42m.
- Composition: base 9m, insert 6m×2 (namely the luffing jib 6m insert), insert 12m×1 (namely luffing jib 12m insert), and tip 9m.

#### 6) Operating Conditions

- H: Operating condition of boom
- HD: Operating conditions of boom + superlift mast
- HDB: Operating conditions of boom + superlift mast + superlift counterweight
- HJ: Operating condition of mixed boom
- HJD: Operating conditions of mixed boom + superlift mast
- HJDB: Operating conditions of mixed boom + superlift mast + superlift counterweight
- LJ: Operating conditions of boom + luffing jib
- LJ: Operating conditions of boom + luffing jib+ superlift mast
- LJDB: Operating conditions of boom + luffing jib + superlift mast + superlift counterweight
- SFHDB: Operating conditions of boom + fixed short jib + superlift mast +superlift counterweight

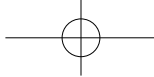

# SAFETY DEVICES

## 1) Load Moment Limiter

- An imported load moment limiter (with main elements imported) is used, and it forms a network with other controllers via CAN bus to realize safe and reliable control. The load moment limiter may automatically detect the weight hoisted by the crane and the angle of boom, and displays the rated loading capacity and actual load, operating radius and the height of lifting hook.
- The load moment limiter system is composed of a large screen color display, basic machine, angle sensor, tension sensor, and pressure sensor, etc.

## 2) Over Roll-out Limit Device for Main and Auxiliary Hooks

The limit switch is used for preventing the hooks from being over-lifted; when the lifting hook is lifted to a certain height, the limit switch will get actuated, with a buzzer on the console sending an alarm; meanwhile the lifting action of the hook is forced to stop and drop to avoid the over roll-out of hook.

## 3) Over-hoist Limit Device for Main and Auxiliary Hooks

When the wire rope is rolled out near the last three circles, the electric control system will automatically shut off the dropping action of hook and give an alarm via the buzzer and display.

## 4) Boom Limit Device

When the elevation angle of boom is over  $87^\circ$  (operating condition of boom is over  $84^\circ$ ) and that of the jib over  $77^\circ$ , corresponding limit switch actuates to make the buzzer give an alarm. At the same time, the boom will stop automatically. At the time, the lifting operation of luffing reel is not functioning, but the dropping operation of luffing reel can be realized. When the lowering angle of boom is lower than  $30^\circ$  and the angle of jib lower than  $20^\circ$ , the manipulation will be limited, and the protection function will be controlled automatically by the load moment limiter.

## 5) Boom Back-stop Device

- The boom and superlift mast have a pair of back-stop cylinders respectively. The high pressure of back-stop cylinder need be conquered when the arm support tilts backward; the hydraulic system automatically compensates the high pressure oil and strains the arm support when the support sets out forward so as to prevent the vibration and back-tilting of arm support in operation.
- The rear mast of luffing jib has a cylinder back-stop device, and the jib base has a pair of cylinders to prevent the front mast of luffing jib from leaning back and to tighten the jib luffing wire rope.
- A back-stop device is equipped to prevent the jib from being tipping back when its angle is up to  $77^\circ$ .

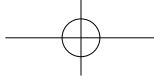

### 6) Winch Mechanism Brake

All winch brakes are spring-loaded normal-engaged disk brakes, which provide a big braking force and are safe, reliable, free of maintenance, and durable.

### 7) CCTV Monitoring System

It can monitor the winding condition of wire ropes on each winch mechanism, status of superlift counterweight, and the situation surrounding equipment.

### 8) Fault Self-diagnosis System

It can eliminate the fault conveniently according to the fault codes.

### 9) Black Box

It can record the operating situation of the driver and operation parameters of equipment, and this is favorable to analysis of accident cause.

### 10) Ground pressure display system

The real-time display system ground pressure developed independently is used to improve the safety in the operation of crane.

### 11) Pharos

It is installed on the top of arm support.

### 12) Anemometer

It is installed on the top of arm support to have real-time monitoring over the wind velocity and send data to the driver's cab to display on the monitor there.

### 13) Electronic Gradiometer

The electronic gradiometer displays the inclining angle of crane on the monitor and guarantees the safe operation of crane.

### 14) Lightning Protection Device

With the lightning protection device, the crane can be safety grounded before the thunderstorm, so as to protect the electric equipment from lightning stroke.

### 15) Hook Clamp

Each kind of lifting hook is equipped with a clamp plate to prevent the wire rope from falling off.

### 16) Slewing and Traveling Alarm

There are audio and light indications during the slewing and traveling.

### 17) Manipulation Release

When the manipulation release switch is pushed down, all manipulation handles are not functioning to prevent misoperation due to body collision when the driver getting on/off the crane.



### **18) Engine Power Limit Load Adjustment and Stalling Protection**

The controller monitors the engine power to prevent the engine from stalling.

### **19) Monitoring System Display**

It can display the water temperature, fuel quantity, accumulated operating duration, oil pressure, engine speed, charging status of battery, and voltage.

### **20) Emergency Operating System**

The independent emergency operating box of circuit is connected to the solenoid valve via the connector. In case of emergency, the main operations like winching, luffing, and slewing can all be realized.

### **21) Remote Monitoring System**

It monitors and analyzes the operation data so as to have remote diagnosis over the faults and thus to solve problems in time.

### **22) Emergency Stop Button**

In case of emergency that the crane is out of control suddenly, press down the emergency stop button so that the hoisting, luffing, slewing and traveling actions are all under emergency braking and the engine shuts down.

### **23) Wireless Remote Control System**

- The wireless remote control system is mainly composed of a receiving system and a transmitting system. The wireless remote control system allows the operator to carry the transmitting device to have remote control over the crane for completing the actions of main mechanisms (including main winch, auxiliary winch, main luffing, superlift luffing, auxiliary luffing, slewing, traveling and superlift counterweight, and extension of the lifting cylinder). It enables the operator to leave the cab for selecting the best visual position, eliminates the inconveniences due to unclear sight or uncoordinated commanding and cooperation, eliminates hidden troubles, increases the flexibility and safety of diver's operation, and improves productivity.
- Meanwhile, 1 LCD display screen is equipped to show the key parameters and alarm parameters of system, which is convenient for the operator to know the status of crane.



# SCC10000

Operating Condition Combination	25
H Operating Condition	26
HDB Operating Condition	29
LJ Operating Condition	33
LJ(DB) Operating Condition	39
HJ Operating Condition	45
HJDB Operating Condition	48
SF <sub>H</sub> DB Operating Condition	51
SF <sub>L</sub> DB Operating Condition	54



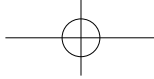

# OPERATING CONDITION COMBINATION

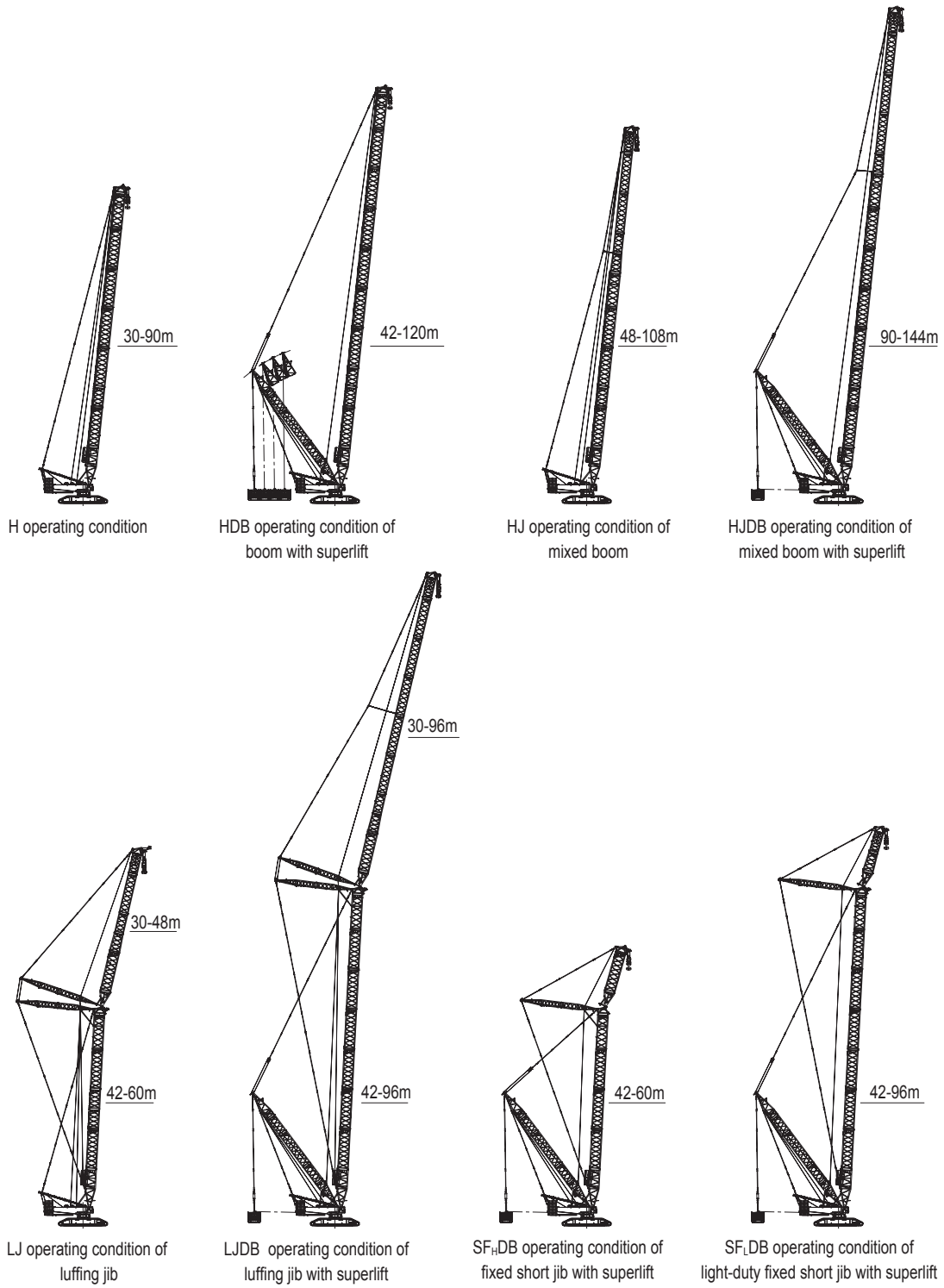

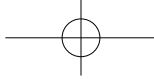

# H OPERATING CONDITION OF BOOM

Boom length (m)	Insert		
	6 m	12mA	12mB
30	1	-	-
36	-	1	-
42	1	1	-
48	-	1	1
54	1	1	1
60	-	1	2
66	1	1	2
72	-	1	3
78	1	1	3
84	-	1	4
90	1	1	4

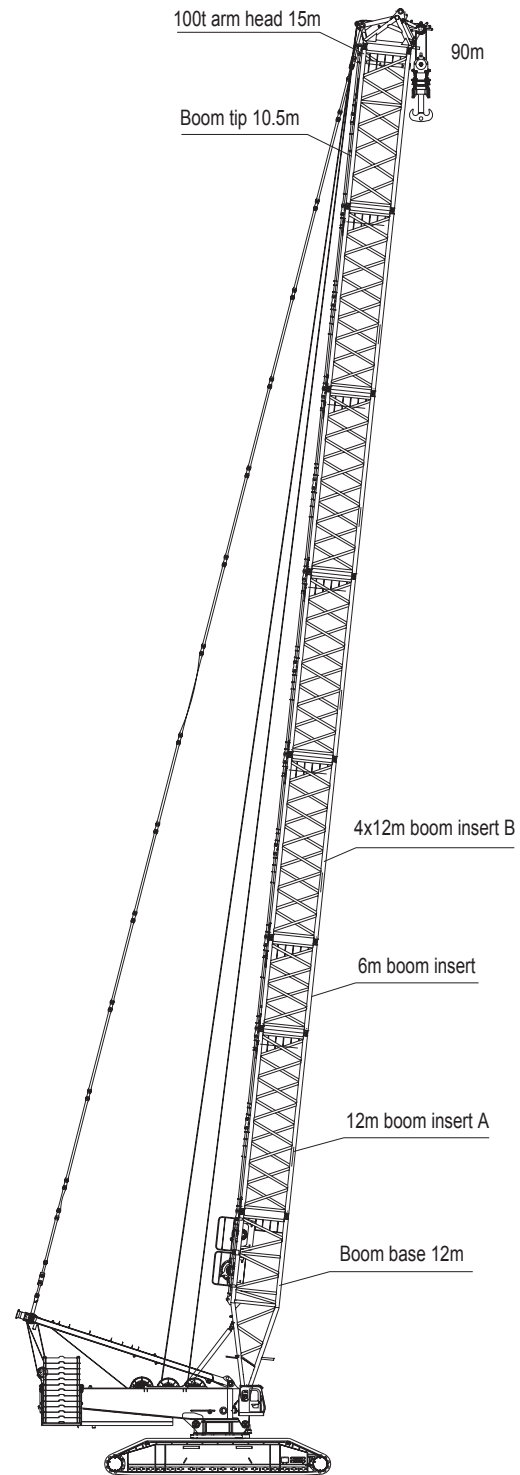

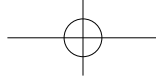

# OPERATING RANGE DIAGRAM OF H OPERATING CONDITION

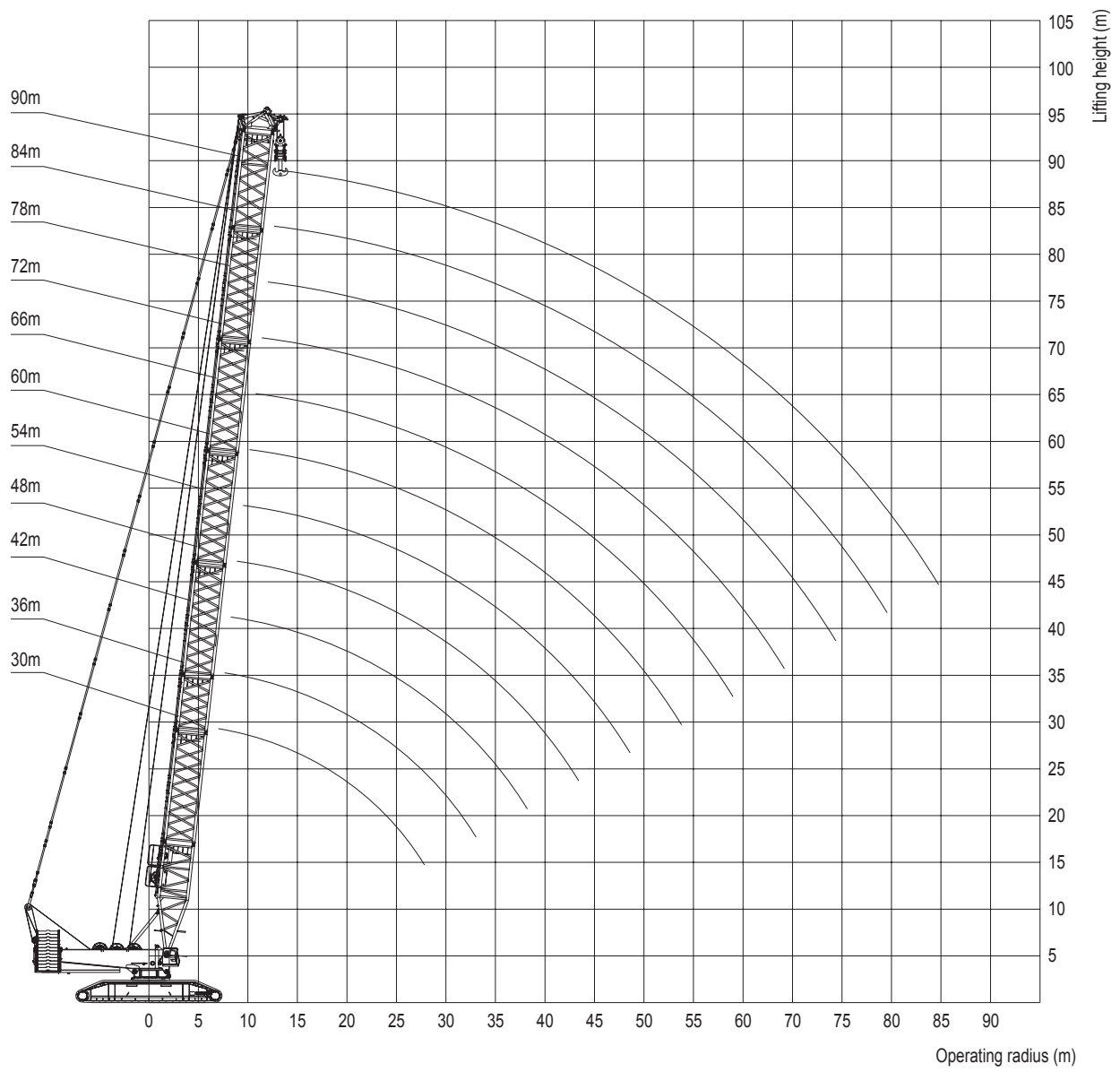

# LOAD CHARTS OF H OPERATING CONDITION

## SCC10000 Crawler Crane – H Operating Condition 250+80

Boom length 30-90m Rear counterweight 250t Central counterweight 80t Unit: (t)

Boom length(m) Radius(m)	30	36	42	48	54	60	66	72	78	84	90	Boom length(m) Radius(m)	
7	727	719										7	
8	653	644	627	618	588							8	
9	575	573	570	564	557	494	475					9	
10	508	506	504	502	499	482	454	417	368			10	
11	455	452	450	448	445	433	413	397	361	314	265	11	
12	411	408	406	404	401	393	376	363	340	307	263	12	
13	374	371	369	367	364	362	346	334	319	299	258	13	
14	342	340	338	335	332	331	318	309	288	281	247	14	
15	315	313	311	308	305	304	291	290	273	263	242	15	
16	292	290	287	285	282	280	278	267	247	244	233	16	
17	271	269	267	264	261	259	256	252	227	228	218	17	
18	253	251	248	246	243	241	239	234	216	214	207	18	
19	237	235	232	230	227	225	223	216	204	201	196	19	
20	222	220	218	216	212	210	209	207	194	191	183	20	
22	197	193	193	191	187	185	183	182	174	170	164	22	
24	177	171	172	170	167	165	163	162	155	152	148	24	
26	159	153	155	153	150	147	145	144	142	139	133	26	
28	144	134	140	138	135	133	131	129	128	126	122	28	
30	132	124	128	125	122	120	118	117	115	113	111	30	
32		114	117	114	111	109	107	105	103	102	100	32	
34		106	107	105	101	99.2	96.9	95.5	93.6	92.5	90.0	34	
36		98.4	98.4	96.1	92.8	90.6	88.2	86.9	84.9	83.8	81.3	36	
38			90.9	88.6	85.2	83.0	80.6	79.2	77.1	76.1	73.5	38	
40			84.3	81.9	78.5	76.2	73.7	72.3	70.2	69.1	66.6	40	
44				70.6	67.0	64.6	62.0	60.4	58.3	57.2	54.6	44	
48				61.8	57.8	55.2	52.4	50.7	48.5	47.5	44.8	48	
52					50.5	47.5	44.5	42.7	40.3	39.3	36.5	52	
56						41.3	37.9	35.9	33.4	32.4	29.5	56	
60						36.6	32.5	30.2	27.5	26.5	23.6	60	
65							27.4	24.5	21.4	20.3	17.3	65	
70								20.1	16.5	15.2	12.1	70	
75									12.7	11.1	7.7	75	
80										7.9		80	
Wind velocity	14.3m/s						12m/s						Wind velocity

Description: 1. The actual lifting capacity must be obtained by deducting the weight of lifting hook, hoisting i tools, and wire rope wound the lifting hook and boom head from the rated lifting capacity in the table.  
 2. The rated hoisting capacities shown in the table are the weights hoisted on a level and hard ground.

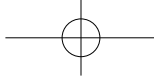

# HDB OPERATING CONDITION WITH SUPERLIFT

Boom length (m)	Insert		
	6 m	12mA	12mB
42	1	1	-
48	-	1	1
54	1	1	1
60	-	1	2
66	1	1	2
72	-	1	3
78	1	1	3
84	-	1	4
90	1	1	4
96	-	1	5
102	1	1	5
108	-	1	6
114	1	1	6
120	2	1	6

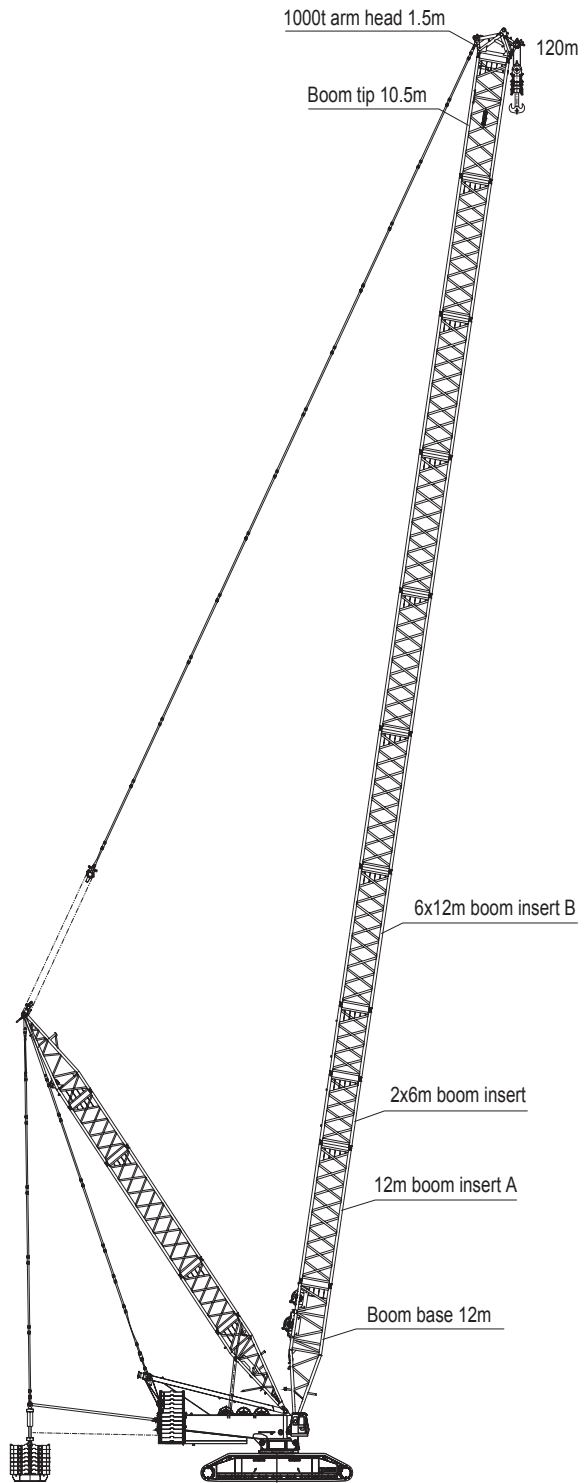

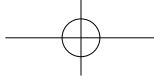

# OPERATING RANGE DIAGRAM OF HDB OPERATING CONDITION

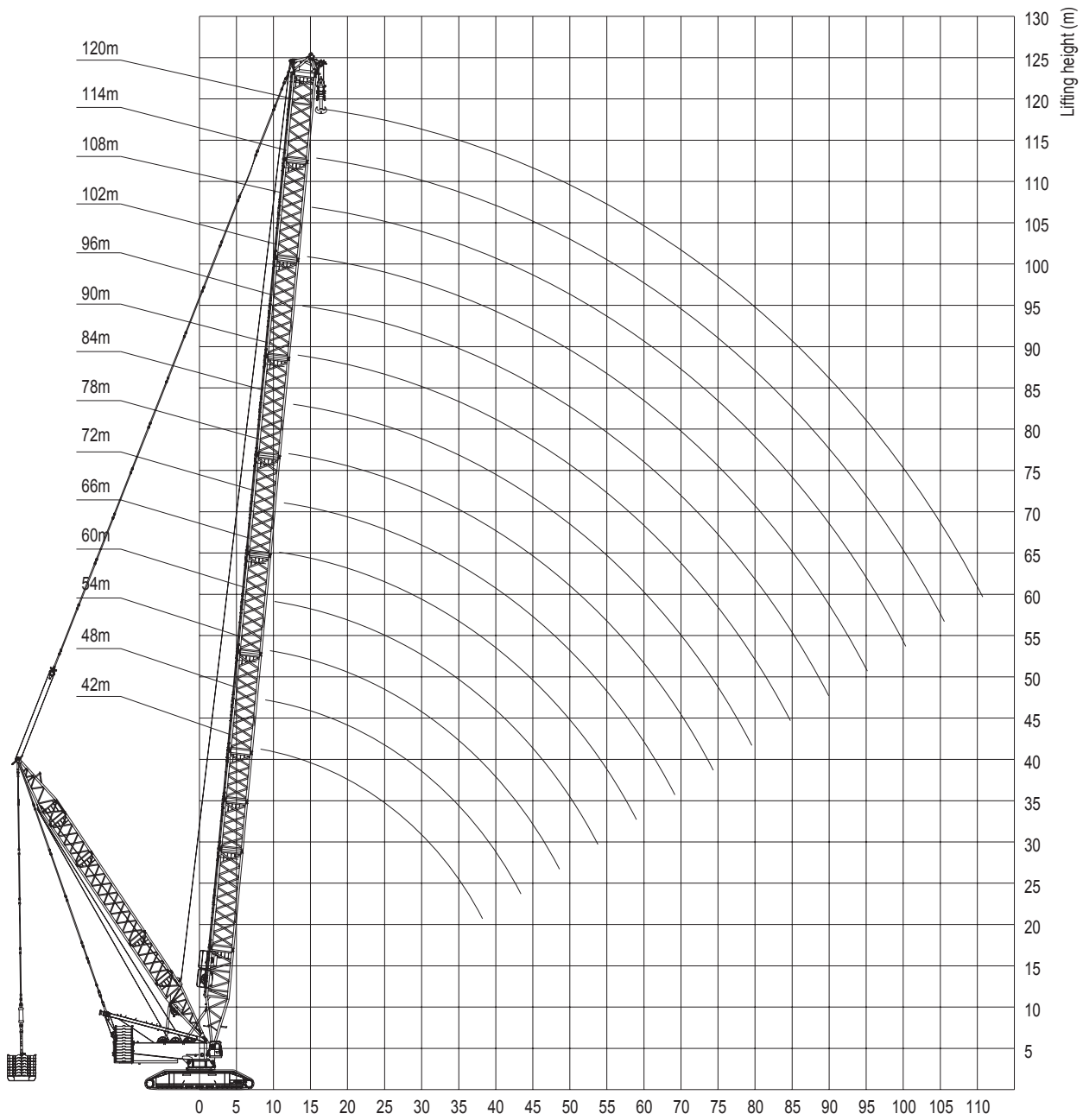

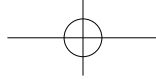

# LOAD CHARTS OF HDB OPERATING CONDITION

## SCC10000 Crawler Crane – Operating Condition of HDB24m450+250 +80

Boom length 42-120m Superlift mast 42m Superlift counterweight 450t Rear counterweight 250t  
Central counterweight 80t Slewing range 0° -360°

Unit: (t)

Boom length (m) Radius(m)	42	48	54	60	66	72	78	84	90	96	102	108	114	120	Boom length(m) Radius(m)
7	1000*														7
8	1000*	981*	911*												8
9	1000*	981*	911*	850*	788*										9
10	1000*	981*	911*	850*	788*	722*	689*								10
11	1000*	981*	911*	850*	788*	722*	689*	638*							11
12	1000*	981*	911*	850*	788*	722*	689*	635*	577*						12
13	995	964*	911*	850*	788*	722*	689*	632*	577*	513*					13
14	961	946	911	850*	788*	722*	685*	629*	574*	513*	449*				14
15	901	892	883	850	788*	722*	679*	625*	572*	510*	449*	394*	346*		15
16	847	838	831	819	788	722*	673*	622*	569*	507*	449*	394*	346*	295*	16
17	799	791	784	773	759	722	665*	618*	565*	504*	449*	394*	346*	295*	17
18	756	748	741	731	718	700	658*	614*	562*	500*	449*	394*	346*	295*	18
19	717	710	703	693	681	664	648	611*	557*	497*	449*	394*	346*	295*	19
20	682	675	669	659	648	631	626	604	554*	494*	448*	392*	346*	295*	20
22	620	614	608	599	589	574	569	565	544	490*	447*	390*	346*	295*	22
24	568	563	557	548	539	526	521	517	513	485	445*	389*	346*	295*	24
26	524	519	514	505	496	484	480	476	473	467	444	387*	346*	295*	26
28	486	481	476	468	460	448	444	441	437	432	433	385*	344*	295*	28
30	439	448	443	435	427	417	413	410	406	402	402	382	342*	292*	30
32	398	419	414	406	399	389	385	382	379	374	375	373	339	290*	32
34	360	394	388	381	374	364	360	358	355	350	351	349	335	287*	34
36	325	370	365	358	351	342	339	336	333	329	330	327	324	282	36
38	292*	339	344	338	331	323	319	316	314	309	310	308	305	279	38
40	260*	310	326	319	313	305	301	298	296	292	293	291	288	273	40
44		257	293	288	281	274	270	268	265	261	262	260	257	253	44
48		201*	248	261	255	248	244	242	239	235	236	234	232	228	48
52			204	238	233	226	222	220	217	213	215	213	210	206	52
56				202	214	207	204	201	198	194	196	194	191	187	56
60				162	196	191	187	185	182	178	179	177	175	171	60
65					156	174	170	167	164	160	162	160	157	153	65
70						149	156	152	149	145	147	145	142	138	70
75							140	140	137	132	134	131	129	125	75
80								129	126	121	122	120	117	114	80
85									116	112	112	110	107	104	85
90										103	104	101	95.1	92.9	90
95											96.9	94.1	84.6	82.6	95
100												87.4	74.6	71.9	100
105													62.5	60.4	105
110													51.1	48.2	110
115														34.5*	115
Wind velocity	14.3m/s				12m/s				9m/s				Wind velocity		

Description: 1. The actual lifting capacity must be obtained by deducting the weight of lifting hook, hoisting tools, and wire rope wound the lifting hook and boom head from the rated lifting capacity in the table.  
2. The rated hoisting capacities shown in the table are the weights hoisted on a level and hard ground.

# LOAD CHARTS OF HDB OPERATING CONDITION

## SCC10000 Crawler Crane – Operating Condition of HDB21m450+250 +80

Boom length 42-120m Superlift mast 42m Superlift counterweight 450t Rear counterweight 250t  
 Central counterweight 80t Slewing range 0° -360°

Unit: (t)

Boom length(m) Radius(m)	42	48	54	60	66	72	78	84	90	96	102	108	114	120	Boom length (m) Radius(m)
7	1000*														7
8	1000*	981*	911*												8
9	1000*	981*	911*	850*	788*										9
10	1000*	981*	911*	850*	788*	722*	689*								10
11	1000*	981*	911*	850*	788*	722*	689*	638*							11
12	1000	981	911*	850*	788*	722*	689*	635*	577*						12
13	952	942	911	850*	788*	722*	689*	632*	577*	513*					13
14	888	878	870	850	788	722*	685*	629*	574*	513*	449*				14
15	831	823	814	799	785	722	679*	625*	572*	510*	449*	394*	346*		15
16	781	774	765	751	738	719	673	622*	569*	507*	449*	394*	346*	295*	16
17	737	730	721	708	696	678	665	618*	565*	504*	449*	394*	346*	295*	17
18	697	690	682	670	658	641	635	614	562*	500*	449*	394*	346*	295*	18
19	661	655	647	635	624	608	602	598	557	497*	449*	394*	346*	295*	19
20	628	622	614	603	593	578	572	568	554	494*	448*	392*	346*	295*	20
22	571	566	558	548	538	525	520	516	512	490	447*	390*	346*	295*	22
24	524	518	511	501	492	480	476	472	468	463	445	389*	346*	295*	24
26	483	478	470	462	453	442	438	434	431	426	426	387	346*	295*	26
28	447	443	435	427	419	409	405	402	398	393	394	385	344	295*	28
30	417	412	404	397	390	380	376	373	370	365	366	363	342	292*	30
32	390	385	377	371	363	354	350	348	345	340	341	338	335	290	32
34	366	361	354	347	340	331	328	325	322	318	319	316	313	287	34
36	339	340	332	326	320	311	308	305	302	298	299	297	294	282	36
38	306	321	313	307	301	293	289	287	284	280	281	279	276	272	38
40	273	304	296	290	284	276	273	270	268	264	265	263	260	256	40
44		269	267	261	255	248	244	242	239	235	237	235	232	228	44
48		214	243	237	231	224	221	218	216	212	213	211	208	205	48
52			216	216	210	204	200	198	196	191	193	191	188	185	52
56				200	193	187	183	181	178	174	176	174	171	167	56
60				172	178	172	168	166	163	159	160	159	156	152	60
65					164	156	152	150	147	143	144	142	140	136	65
70						144	139	136	133	129	130	128	126	122	70
75							128	125	121	117	118	116	113	110	75
80								115	111	107	108	106	103	99.8	80
85									103	98.5	99.3	97.0	94.1	90.5	85
90										90.9	91.5	89.0	86.0	82.3	90
95											84.8	82.0	78.8	75.1	95
100												75.9	72.4	68.6	100
105													62.5	60.4	105
110														51.1	110
115															115
Wind velocity	14.3m/s				12m/s				9m/s				Wind velocity		

Description: 1. The actual lifting capacity must be obtained by deducting the weight of lifting hook, hoisting tools, and wire rope wound the lifting hook and boom head from the rated lifting capacity in the table.  
 2. The rated hoisting capacities shown in the table are the weights hoisted on a level and hard ground.



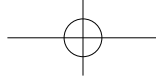

# LJ(DB) OPERATING CONDITION OF LUFFING JIB (WITH SUPERLIFT)

Jib length (m)	Jib insert	Jib insert			Boom length (m)	Boom angle
		6m	12m B	12m C		
30	6m×1 Reducing arm	-	1	-	42~60 (LJ)	87°
36		1	1	-		
42		-	1	1		
48		1	1	1		
54		-	1	2		
60		1	1	2		
66		-	1	3	42~96 (LJDB)	
72		1	1	3		
78		-	1	4		
84		1	1	4		
90		-	1	5		
96	1	1	5			

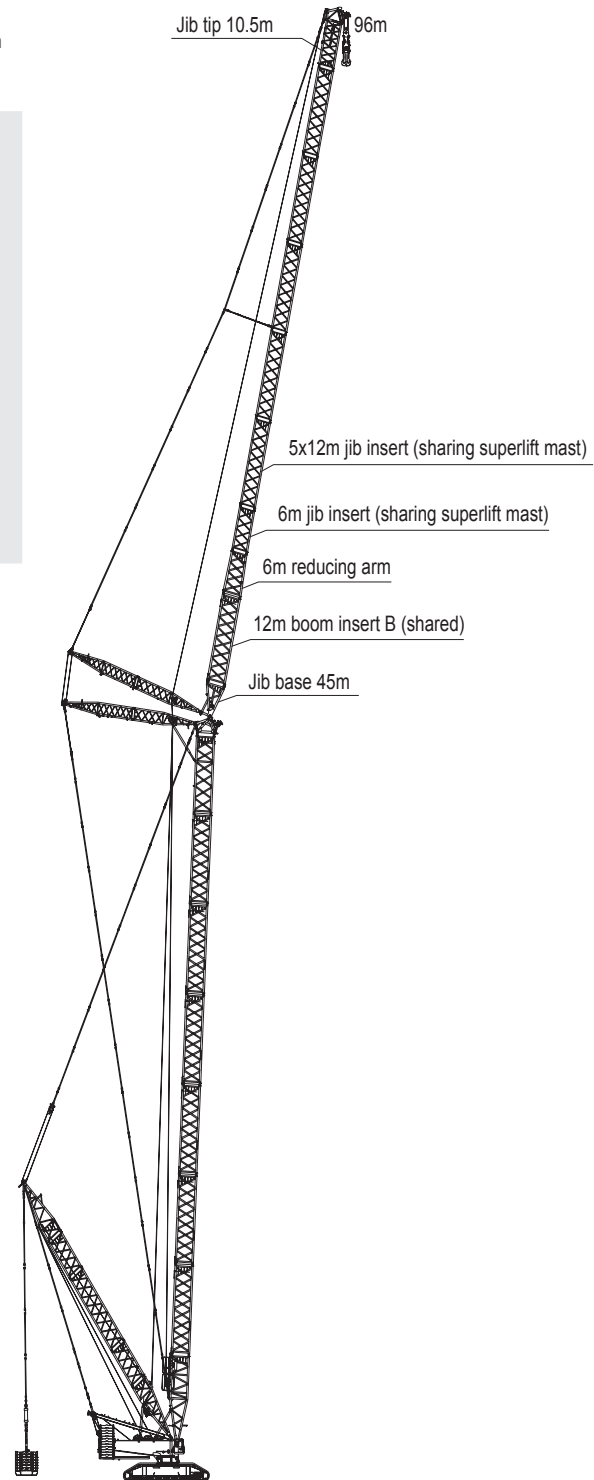

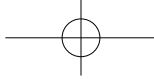

# OPERATING RANGE DIAGRAM OF LJ OPERATING CONDITION

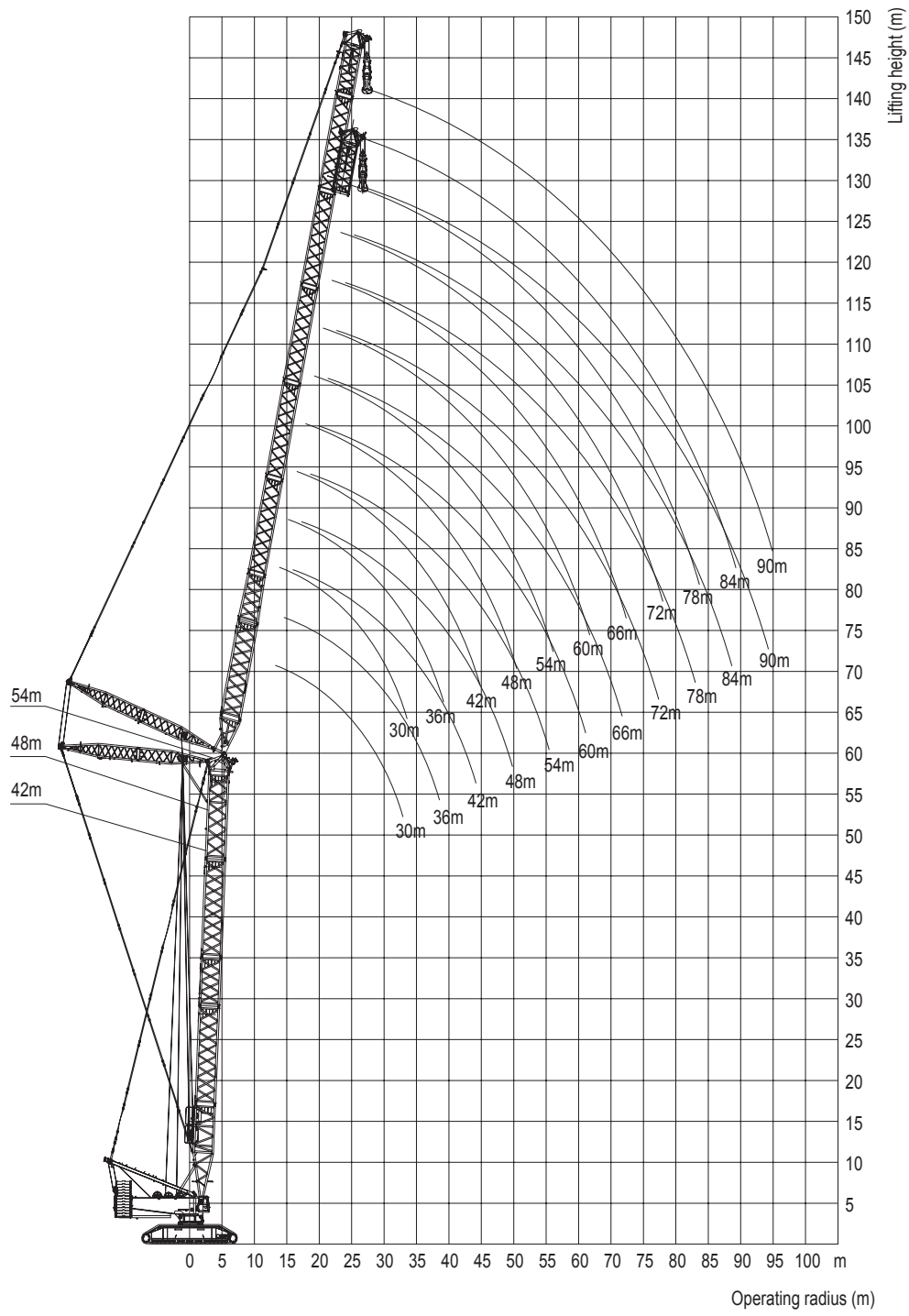

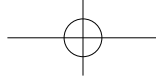

# LOAD CHARTS OF LJ OPERATING CONDITION

## SCC10000 Crawler Crane – Operating Condition of LJ42 85° 250+80

42m boom Boom angle 85° Jib 30-96m Rear counterweight 250t Central counterweight 80t

Unit: (t)

Boom length (m) Radius(m)	30	36	42	48	54	60	66	72	78	84	90	96	Boom length(m) Radius(m)
14	340												14
15	320	309											15
16	298	290											16
17	283	272											17
18	268	259											18
19	254	247	239										19
20	235	234	225										20
22	218	212	207	201	194								22
24	200	194	192	183	178	172							24
26	182	178	177	170	164	158	148						26
28	166	165	161	157	152	147	143	121					28
30	153	151	149	146	141	136	133	120	105	88.6			30
32	141	140	138	136	131	129	125	116	105	88.6	75.7		32
34	131	129	128	126	123	121	117	113	102	87.6	75.2	65.9	34
36		120	119	117	114	112	110	107	101	86.0	74.6	65.4	36
38		112	111	109	106	104	102	99.4	98.2	85.0	73.5	64.7	38
40		105	103	101	99.3	96.8	95.2	92.2	91.0	84.0	72.3	63.3	40
42			96.9	94.8	92.8	90.4	88.7	85.7	84.6	81.9	70.9	62.2	42
44			91.0	89.0	87.0	84.5	82.9	79.8	78.7	76.1	69.0	61.0	44
46			85.7	83.6	81.6	79.2	77.6	74.5	73.3	70.7	67.8	59.5	46
48				78.8	76.8	74.3	72.7	69.6	68.5	65.8	65.0	57.9	48
52					68.3	65.8	64.2	61.1	59.9	57.2	56.4	53.7	52
56						61.1	58.6	56.9	53.8	52.6	49.9	46.4	56
60							52.5	50.8	47.6	46.3	43.7	40.1	60
65								44.3	41.1	39.7	37.0	36.0	65
70									35.7	34.1	31.4	30.3	70
75										29.5	26.7	25.5	75
80											25.7	22.7	80
85												19.5	85
90													90
95													95

- Description: 1. The actual lifting capacity must be obtained by deducting the weight of lifting hook, hoisting tools, and wire rope wound the lifting hook and boom head from the rated lifting capacity in the table.  
2. The rated hoisting capacities shown in the table are the weights hoisted on a level and hard ground.

# LOAD CHARTS OF LJ OPERATING CONDITION

## SCC10000 Crawler Crane – Operating Condition of LJ42\_85°\_250+80

48m boom Boom angle 85° Jib 30-96m Rear counterweight 250t Central counterweight 80t

Unit: (t)

Boom length(m) Radius(m)	30	36	42	48	54	60	66	72	78	84	90	96	Boom length(m) Radius(m)
17	275												17
18	262	250											18
19	246	238											19
20	236	227	220										20
22	216	207	200	195									22
24	198	190	183	178	173								24
26	180	174	170	165	160	156	136						26
28	165	163	158	153	148	144	135	115					28
30	151	149	147	141	138	134	130	114	98.9				30
32	139	138	136	130	128	125	124	112	97.9	83.4	73.3		32
34	129	128	126	120	122	117	115	109	96.4	82.8	72.3	61.8	34
36		119	117	111	113	109	107	106	94.6	81.6	71.3	61.3	36
38		111	109	104	105	102	101	98.7	91.9	80.8	70.5	60.8	38
40		103	102	96.8	97.6	95.1	93.4	91.6	89.3	79.1	69.6	60.6	40
42			95.4	90.5	91.2	88.7	87.0	85.1	82.9	77.6	68.8	59.7	42
44			89.5	84.9	85.4	82.9	81.2	79.3	77.0	75.3	67.8	59.2	44
46			84.2	79.7	80.1	77.6	75.9	74.0	71.7	70.4	66.6	58.5	46
48				75.0	75.3	72.8	71.1	69.2	66.9	65.5	63.4	57.3	48
52				66.9	66.8	64.3	62.7	60.6	58.4	57.0	54.9	53.6	52
56					59.7	57.2	55.5	53.4	51.2	49.7	47.6	46.3	56
60						51.1	49.4	47.2	45.0	43.4	41.3	40.0	60
65							43.0	40.7	38.4	36.8	34.7	33.3	65
70								35.2	32.9	31.2	29.0	27.6	70
75								30.7	28.3	26.4	24.3	22.7	75
80									24.5	22.4	20.2	18.5	80
85										19.1	16.7	14.9	85
90											13.8	11.9	90
95												9.3	95

Description: 1. The actual lifting capacity must be obtained by deducting the weight of lifting hook, hoisting tools, and wire rope wound the lifting hook and boom head from the rated lifting capacity in the table.  
 2. The rated hoisting capacities shown in the table are the weights hoisted on a level and hard ground.

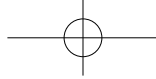

# LOAD CHARTS OF LJ OPERATING CONDITION

## SCC10000 Crawler Crane – Operating Condition of LJ42\_85°\_250+80

54m boom Boom angle 85° Jib 30-84m Rear counterweight 250t Central counterweight 80t

Unit: (t)

Boom length(m) Radius(m)	30	36	42	48	54	60	66	72	78	84	Boom length(m) Radius(m)
17	264										17
18	250										18
19	237	227									19
20	226	218	212								20
22	206	200	190	187							22
24	189	184	178	172	164						24
26	178	169	165	159	155	143					26
28	162	156	155	148	144	139	124	107			28
30	149	146	144	138	133	129	123	106	90.6		30
32	138	136	133	126	125	121	118	105	89.6	78.5	32
34	127	126	124	121	119	115	111	102	89.1	77.8	34
36	118	117	115	112	111	108	105	100	88.1	76.8	36
38		109	107	105	103	100	99.7	96.7	86.5	76.0	38
40		102	100	97.8	95.7	93.2	92.6	89.6	85.1	75.0	40
42			93.6	91.4	89.3	86.8	86.3	83.3	82.3	73.5	42
44			87.8	85.7	83.6	81.1	80.5	77.5	76.5	71.7	44
46			82.5	80.4	78.3	75.8	75.2	72.2	71.2	68.6	46
48				75.6	73.6	71.0	70.5	67.4	66.4	63.8	48
52				67.3	65.2	62.7	62.0	59.0	57.9	55.3	52
56					58.1	55.6	54.9	51.8	50.8	48.1	56
60						49.6	48.8	45.7	44.6	42.0	60
65							42.3	39.2	38.0	35.4	65
70								33.8	32.5	29.8	70
75								29.4	27.8	25.1	75
80									24.0	21.1	80
85										17.8	85

- Description: 1. The actual lifting capacity must be obtained by deducting the weight of lifting hook, hoisting tools, and wire rope wound the lifting hook and boom head from the rated lifting capacity in the table.  
2. The rated hoisting capacities shown in the table are the weights hoisted on a level and hard ground.

# LOAD CHARTS OF LJ OPERATING CONDITION

## SCC10000 Crawler Crane – Operating Condition of LJ42\_85°\_250+80

60m boom Boom angle 85° Jib 30-48m Rear counterweight 250t Central counterweight 80t

					Unit:(t)
Boom length(m) Radius(m)	30	36	42	48	Boom length(m) Radius(m)
18	239				18
19	227	194			19
20	215	194			20
22	196	188	185	167	22
24	180	175	173	163	24
26	165	163	161	153	26
28	152	151	149	142	28
30	140	139	139	133	30
32	132	128	129	124	32
34	123	122	122	115	34
36	116	113	113	109	36
38		107	105	103	38
40		99.9	98.3	95.3	40
42		93.4	91.9	89.7	42
44			86.2	84.0	44
46			80.9	78.8	46
48				74.0	48
52				65.7	52

- Description: 1. The actual lifting capacity must be obtained by deducting the weight of lifting hook, hoisting i tools, and wire rope wound the lifting hook and boom head from the rated lifting capacity in the table.  
 2. The rated hoisting capacities shown in the table are the weights hoisted on a level and hard ground.

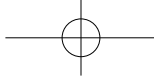

# OPERATING RANGE DIAGRAM OF HJDB OPERATING CONDITION

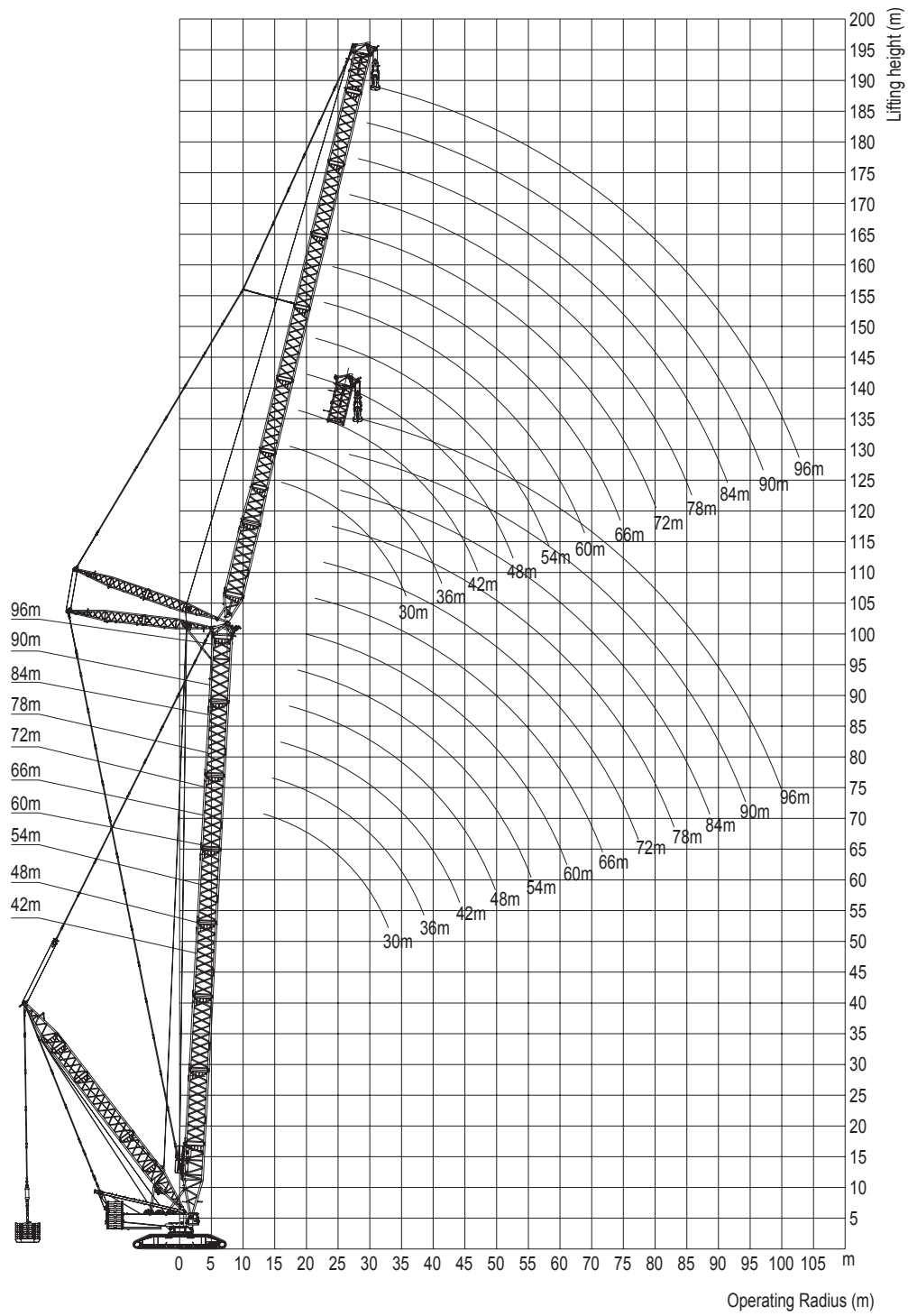

# LOAD CHARTS OF LJDB OPERATING CONDITION

## SCC10000 Crawler Crane – Operating Condition of LJDB\_54\_85°\_24m\_450+250+80

Boom 54m Boom angle 85° Jib 30-96m Superlift mast 42m Superlift radius 24m Superlift counterweight 450t Rear counterweight 250t Central counterweight 80t Slewing range 0° -360°

Unit:(t)

Boom length(m) Radius(m)	30	36	42	48	54	60	66	72	78	84	90	96	Boom length(m) Radius(m)
17	463*												17
18	463*												18
19	463*	463*											19
20	461*	458*	422*										20
22	458*	444*	412*	391*									22
24	442*	424*	403*	381*	349*								24
26	422*	409*	391*	369*	347*	300*							26
28	399*	393*	376*	357*	338*	298*	258*	224*					28
30	374*	375*	362*	346*	326*	295*	257*	224*	195*				30
32	332*	345*	345*	331*	311*	286*	255*	223*	195*	170*			32
34	294*	311*	320*	313*	294*	275*	251*	222*	194*	170*	152*	139*	34
36	254*	281*	292*	292*	278*	262*	243*	220*	193*	170*	152*	139*	36
38		253*	266*	274*	261*	249*	232*	216*	191*	169*	151*	138*	38
40		227*	243*	252*	246*	236*	222*	210*	189*	169*	150*	135*	40
42			222*	233*	231*	223*	212*	202*	186*	167*	146*	133*	42
44			203*	215*	215*	211*	201*	194*	181*	164*	142*	129*	44
46			183*	198*	200*	198*	191*	186*	175*	159*	136*	123*	46
48				183*	188*	187*	182*	177*	168*	154*	131*	118*	48
52				153*	162*	165*	162*	161*	155*	142*	119*	107*	52
56					138*	146*	146*	146*	142*	129*	108*	95.8*	56
60						127*	129*	131*	129*	117*	97.9*	84.5*	60
65							112*	116*	116*	104*	86.5*	72.1*	65
70								101*	102*	92.7*	75.2*	59.7*	70
75								85.4*	88.3*	81.4*	64.9*	49.4*	75
80									74.5*	72.1*	55.6*	40.2*	80
85										63.9*	47.4*	30.9*	85
90											39.1*	21.6*	90
95												14.4*	95

Description: 1. The actual lifting capacity must be obtained by deducting the weight of lifting hook, hoisting tools, and wire rope wound the lifting hook and boom head from the rated lifting capacity in the table.  
 2. The rated hoisting capacities shown in the table are the weights hoisted on a level and hard ground.



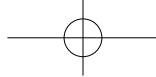

# LOAD CHARTS OF LJDB OPERATING CONDITION

## SCC10000 Crawler Crane – Operating Condition of LJDB\_60\_85°\_24m\_450+250+80

Boom 60m Boom angle 85° Jib 30-96m Superlift mast 42m Superlift radius 24m Superlift counterweight 450t Rear counterweight 250t Central counterweight 80t Slewing range 0° -360°

		Unit:(t)											
Boom length(m) Radius(m)	30	36	42	48	54	60	66	72	78	84	90	96	Boom length(m) Radius(m)
17													17
18	461*												18
19	455*	406*											19
20	448*	406*											20
22	434*	401*	379*	356*									22
24	420*	396*	373*	353*	317*								24
26	406*	389*	365*	345*	314*	275*							26
28	391*	370*	352*	333*	310*	272*	238*						28
30	368*	354*	337*	319*	298*	268*	237*	209*	183*				30
32	342*	329*	319*	303*	284*	260*	234*	208*	183*	159*			32
34	300*	304*	296*	286*	268*	250*	229*	206*	182*	159*	140*		34
36	*	282*	272*	267*	253*	238*	221*	202*	181*	158*	139*	119*	36
38		260*	252*	251*	238*	227*	211*	197*	179*	157*	138*	118*	38
40		233*	234*	233*	225*	216*	202*	191*	176*	156*	136*	117*	40
42		*	218*	216*	212*	203*	192*	185*	170*	154*	135*	115*	42
44			201*	200*	197*	192*	183*	178*	164*	152*	133*	111*	44
46			*	188*	185*	182*	174*	169*	158*	148*	130*	107*	46
48				176*	176*	170*	164*	160*	153*	144*	127*	103*	48
52				*	152*	150*	147*	146*	141*	134*	118*	95.8*	52
56					*	134*	132*	131*	129*	123*	108*	87.6*	56
60						*	119*	119*	117*	113*	96.8*	78.3*	60
65							103*	105*	104*	101*	85.5*	68*	65
70							*	92.7*	92.7*	89.6*	74.2*	58.7*	70
75								*	82.4*	79.3*	64.9*	49.4*	75
80									*	71.1*	56.7*	41.2*	80
85										*	48.4*	34*	85
90											*	26.8*	90
95												20.6*	95

- Description: 1. The actual lifting capacity must be obtained by deducting the weight of lifting hook, hoisting tools, and wire rope wound the lifting hook and boom head from the rated lifting capacity in the table.  
2. The rated hoisting capacities shown in the table are the weights hoisted on a level and hard ground.

# LOAD CHARTS OF LJDB OPERATING CONDITION

## SCC10000 Crawler Crane – Operating Condition of LJDB\_66\_85°\_24m\_450+250+80

Boom 60m Boom angle 85° Jib 30-96m Superlift mast 42m Superlift radius 24m Superlift counterweight 450t Rear counterweight 250t Central counterweight 80t Slewing range 0° -360°

													Unit:(t)	
Boom length(m) Radius(m)	30	36	42	48	54	60	66	72	78	84	90	96	Boom length(m) Radius(m)	
18	453*												18	
19	450*												19	
20	442*	396*											20	
22	425*	381*	355*										22	
24	409*	364*	345*	324*									24	
26	395*	352*	333*	316*	288*	252*							26	
28	378*	339*	322*	305*	284*	252*	220*						28	
30	356*	322*	307*	290*	270*	249*	220*	194*					30	
32	335*	300*	288*	273*	258*	241*	218*	193*	172*	150*			32	
34	306*	279*	269*	257*	245*	230*	214*	192*	170*	150*	132*		34	
36	274*	258*	251*	242*	231*	219*	206*	191*	169*	149*	132*	118*	36	
38		238*	233*	225*	218*	208*	197*	184*	168*	148*	132*	118*	38	
40		223*	216*	211*	206*	197*	188*	178*	165*	147*	131*	118*	40	
42		209*	201*	197*	193*	186*	179*	170*	160*	145*	131*	117*	42	
44			188*	184*	181*	176*	170*	163*	154*	142*	130*	116*	44	
46			176*	173*	169*	165*	162*	156*	148*	139*	129*	115*	46	
48			165*	161*	159*	156*	153*	149*	142*	133*	126*	111*	48	
52				143*	141*	139*	136*	134*	129*	125*	117*	101*	52	
56					125*	123*	122*	121*	118*	115*	109*	93.7*	56	
60						110*	110*	109*	107*	105*	98.9*	84.5*	60	
65							98.9*	96.8*	95.8*	94.8*	94.8*	86.5*	73.1*	65
70								87.6*	86.5*	85.5*	84.5*	76.2*	63.9*	70
75									77.3*	76.2*	75.2*	65.9*	54.6*	75
80										69*	68*	56.7*	46.4*	80
85											61.8*	49.4*	38.1*	85
90												42.2*	31.9*	90
95													26.8*	95

- Description: 1. The actual lifting capacity must be obtained by deducting the weight of lifting hook, hoisting tools, and wire rope from the lifting hook and boom head from the rated lifting capacity in the table.  
 2. The rated hoisting capacities shown in the table are the weights hoisted on a level and hard ground.

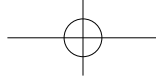

# LOAD CHARTS OF LJDB OPERATING CONDITION

## SCC10000 Crawler Crane – Operating Condition of LJDB\_78\_85°\_24m\_450+250+80

Boom 60m Boom angle 85° Jib 30-96m Superlift mast 42m Superlift radius 24m Superlift counterweight 450t Rear counterweight 250t Central counterweight 80t Slewing range 0° -360°

Unit:(t)

Boom length(m) Radius(m)	30	36	42	48	54	60	66	72	78	84	90	96	Boom length(m) Radius(m)
19	350*												19
20	348*												20
22	344*	325*	304*										22
24	333*	317*	298*	272*									24
26	319*	304*	289*	264*	234*								26
28	306*	292*	275*	256*	233*	209*							28
30	294*	275*	260*	244*	227*	208*	184*	163*					30
32	277*	256*	244*	231*	217*	202*	183*	163*	145*				32
34	258*	238*	229*	219*	207*	193*	181*	162*	145*	129*			34
36	241*	222*	214*	206*	196*	186*	174*	160*	144*	129*	114*	100*	36
38	224*	208*	200*	194*	186*	177*	166*	156*	143*	128*	114*	100*	38
40		193*	187*	182*	176*	168*	159*	150*	141*	127*	114*	100*	40
42		182*	175*	170*	165*	159*	152*	144*	135*	126*	113*	100*	42
44			164*	160*	155*	151*	145*	139*	130*	122*	112*	99.9*	44
46			155*	150*	146*	143*	138*	132*	125*	118*	110*	98.9*	46
48			146*	141*	138*	134*	130*	126*	121*	114*	107*	95.8*	48
52				125*	123*	120*	118*	115*	111*	106*	99.9*	90.6*	52
56					110*	108*	106*	104*	100*	97.9*	93.7*	84.5*	56
60					98.9*	96.8*	94.8*	94.8*	92.7*	89.6*	86.5*	78.3*	60
65						86.5*	84.5*	84.5*	82.4*	81.4*	79.3*	73.1*	65
70							74.2*	74.2*	73.1*	72.1*	70*	65.9*	70
75								67*	65.9*	64.9*	63.9*	59.7*	75
80									58.7*	57.7*	56.7*	53.6*	80
85										53.6*	51.5*	47.4*	85
90											44.3*	41.2*	90
95												36.1*	95
100												30.9*	100

- Description: 1. The actual lifting capacity must be obtained by deducting the weight of lifting hook, hoisting tools, and wire rope wound the lifting hook and boom head from the rated lifting capacity in the table.  
2. The rated hoisting capacities shown in the table are the weights hoisted on a level and hard ground.

# LOAD CHARTS OF LJDB OPERATING CONDITION

## SCC10000 Crawler Crane – Operating Condition of LJDB\_90\_85°\_24m\_450+250+80

Boom 90m Boom angle 85° Jib 30-96m Superlift mast 42m Superlift radius 24m Superlift counterweight 450t Rear counterweight 250t Central counterweight 80t Slewing range 0° -360°

Unit:(t)

Boom length(m) Radius(m)	30	36	42	48	54	60	66	72	78	84	90	96	Boom length (m) Radius(m)
20	278*												20
22	276*	252*											22
24	272*	250*	231*										24
26	266*	247*	229*	221*									26
28	259*	241*	226*	215*	193*	173*							28
30	250*	232*	219*	206*	189*	172*	152*						30
32	237*	219*	208*	195*	183*	169*	152*	136*					32
34	224*	206*	196*	186*	175*	164*	151*	136*	121*	109*			34
36	212*	192*	184*	176*	166*	157*	147*	135*	120*	109*	97.9*		36
38	197*	181*	173*	166*	157*	151*	142*	132*	119*	108*	97.9*	88.6*	38
40		169*	162*	157*	150*	144*	135*	128*	118*	107*	97.9*	88.6*	40
42		160*	153*	148*	143*	136*	130*	123*	115*	106*	96.8*	88.6*	42
44		151*	144*	139*	134*	130*	124*	118*	111*	104*	95.8*	87.6*	44
46			135*	131*	127*	123*	118*	113*	107*	100*	93.7*	86.5*	46
48			128*	124*	120*	116*	113*	109*	103*	96.8*	90.6*	84.5*	48
52				111*	108*	105*	101*	98.9*	94.8*	89.6*	85.5*	81.4*	52
56				100*	96.8*	94.8*	91.7*	89.6*	86.5*	83.4*	79.3*	75.2*	56
60					87.6*	85.5*	83.4*	81.4*	79.3*	76.2*	73.1*	70*	60
65						76.2*	74.2*	73.1*	71.1*	69*	67*	63.9*	65
70							65.9*	64.9*	62.8*	60.8*	59.7*	58.7*	70
75								58.7*	57.7*	55.6*	54.6*	53.6*	75
80									51.5*	49.4*	48.4*	47.4*	80
85										45.3*	43.3*	42.2*	85
90											39.1*	37.1*	90
95											36.1*	34*	95
100												30.9*	100

Description: 1. The actual lifting capacity must be obtained by deducting the weight of lifting hook, hoisting i tools, and wire rope wound the lifting hook and boom head from the rated lifting capacity in the table.  
 2. The rated hoisting capacities shown in the table are the weights hoisted on a level and hard ground.

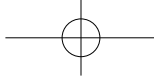

# HJ OPERATING CONDITION OF MIXED BOOM

Boom length (m)	Boom insert		Jib insert	
	6m	12m B	6m	12m C
48	-	-	-	-
54	1	-	-	-
60	-	1	-	-
66	1	1	-	-
72	-	2	-	-
78	-	2	1	-
84	-	2	-	1
90	-	2	1	1
96	-	3	-	1

Note: The basic boom combination of mixed boom is 48m long in total, including 12m boom base, 12m thick boom insert, 6m transitional arm, 7.5m jib tip.

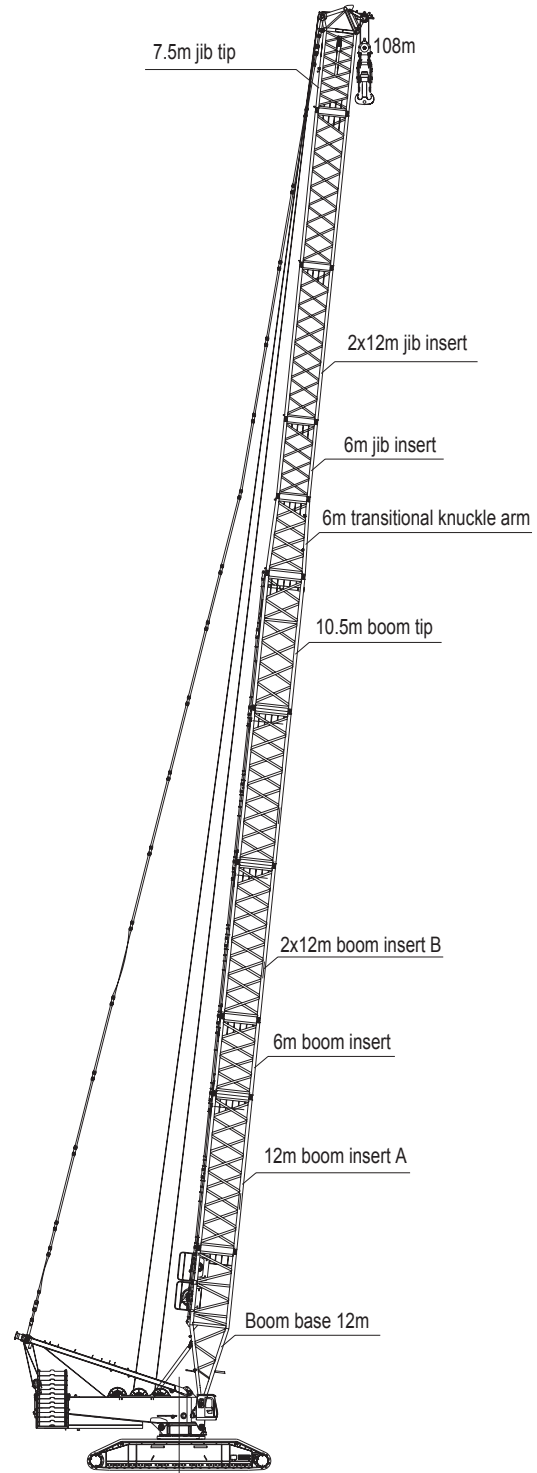

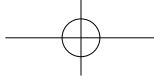

# OPERATING RANGE DIAGRAM OF HJ OPERATING CONDITION

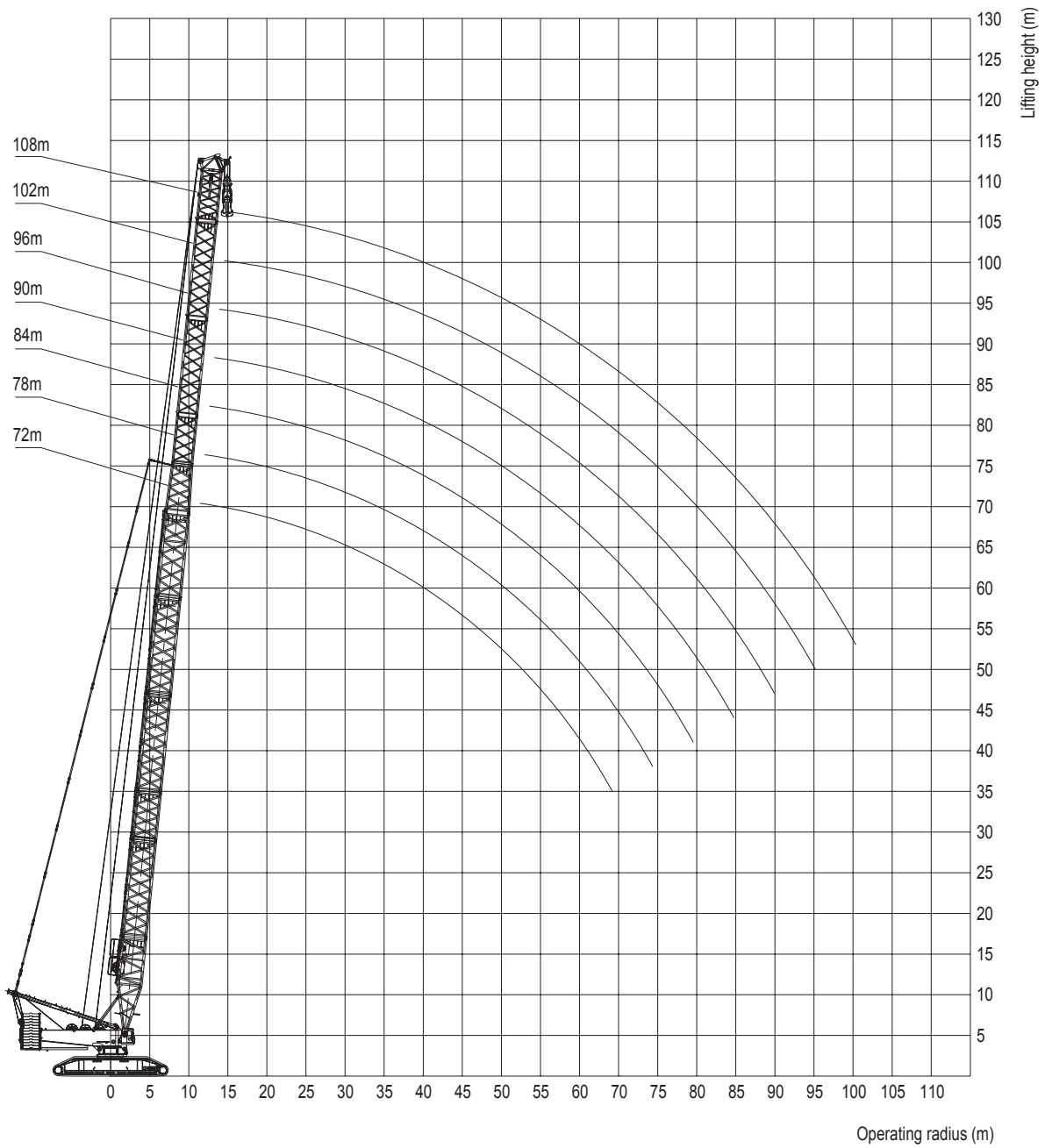

# LOAD CHARTS OF HJ OPERATING CONDITION

## SCC10000 Crawler Crane – HJ Operating Condition\_250+80

Length of mixed boom 48-96m Rear counterweight 250t Central counterweight 80t Unit:(t)

Boom length(m) Radius(m)	48	54	60	66	72	78	84	90	96	Boom length(m) Radius(m)	
8	464									8	
9	464	464	455							9	
10	464	449	440	427	414					10	
11	424	406	400	394	387	346	280			11	
12	386	369	364	359	353	345	278	242		12	
13	354	339	334	329	323	319	274	241	237	13	
14	326	312	308	303	298	294	269	238	232	14	
15	302	289	285	281	276	272	263	232	227	15	
16	281	269	265	261	256	253	249	228	219	16	
17	263	251	247	244	239	236	232	221	214	17	
18	246	235	232	228	224	220	217	211	204	18	
19	231	221	217	214	210	207	204	199	196	19	
20	218	208	205	202	197	194	192	188	184	20	
22	195	186	183	180	176	173	170	167	163	22	
24	175	167	164	161	158	155	152	149	145	24	
26	159	151	149	146	142	139	137	134	130	26	
28	142	138	135	133	129	126	124	121	118	28	
30	133	126	124	121	117	115	113	110	106	30	
32	118	115	113	111	107	105	103	100	96.5	32	
34	109	105	104	102	98.4	95.9	94.0	91.4	87.7	34	
36	101	93.7	96.4	94.1	90.5	88.1	86.2	83.6	80.0	36	
38	92.7	89.6	89.2	87.0	83.4	81.0	79.1	76.6	73.0	38	
40	85.5	80.3	82.8	80.6	77.0	74.7	72.8	70.3	66.7	40	
42	80.3	76.2	77.0	74.8	71.3	68.9	67.1	64.6	61.0	42	
44	76.2	72.1	71.8	69.6	66.1	63.7	61.9	59.4	55.9	44	
46	72.1	65.9	67.0	64.8	61.3	59.0	57.2	54.7	51.1	46	
48		62.8	62.6	60.4	56.9	54.6	52.8	50.4	46.8	48	
52		57.6	55.0	52.8	49.3	47.0	45.2	42.7	39.2	52	
56			48.6	46.3	42.8	40.5	38.7	36.2	32.7	56	
60			43.4	40.9	37.3	34.9	33.1	30.6	27.1	60	
65				35.3	31.5	29.0	27.2	24.7	21.1	65	
70					26.8	24.2	22.2	19.7	16.1	70	
75						20.3	18.1	15.5	11.8	75	
80							14.8	12.0	8.3	80	
85								9.2	5.3	85	
90									2.9	90	
Wind velocity	14.3m/s					12m/s					Wind velocity

Description: 1. The actual lifting capacity must be obtained by deducting the weight of lifting hook, hoisting i tools, and wire rope wound the lifting hook and boom head from the rated lifting capacity in the table.  
2. The rated hoisting capacities shown in the table are the weights hoisted on a level and hard ground.

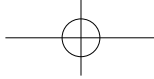

## HJDB OPERATING CONDITION OF MIXED BOOM WITH SUPERLIFT

Boom length (m)	Boom insert		Jib insert	
	6m	12m B	6m	12m C
90	-	2	1	1
96	-	3	-	1
102	-	3	1	1
108	1	2	1	2
114	-	5	1	-
120	-	5	-	1
126	-	5	1	1
132	-	5	-	2
138	-	5	1	2
144	-	5	-	3

Note: The basic arm combination of mixed boom is 48m long in total, including 12m boom base, 12m thick boom insert, 6m transitional arm, 7.5m jib tip.

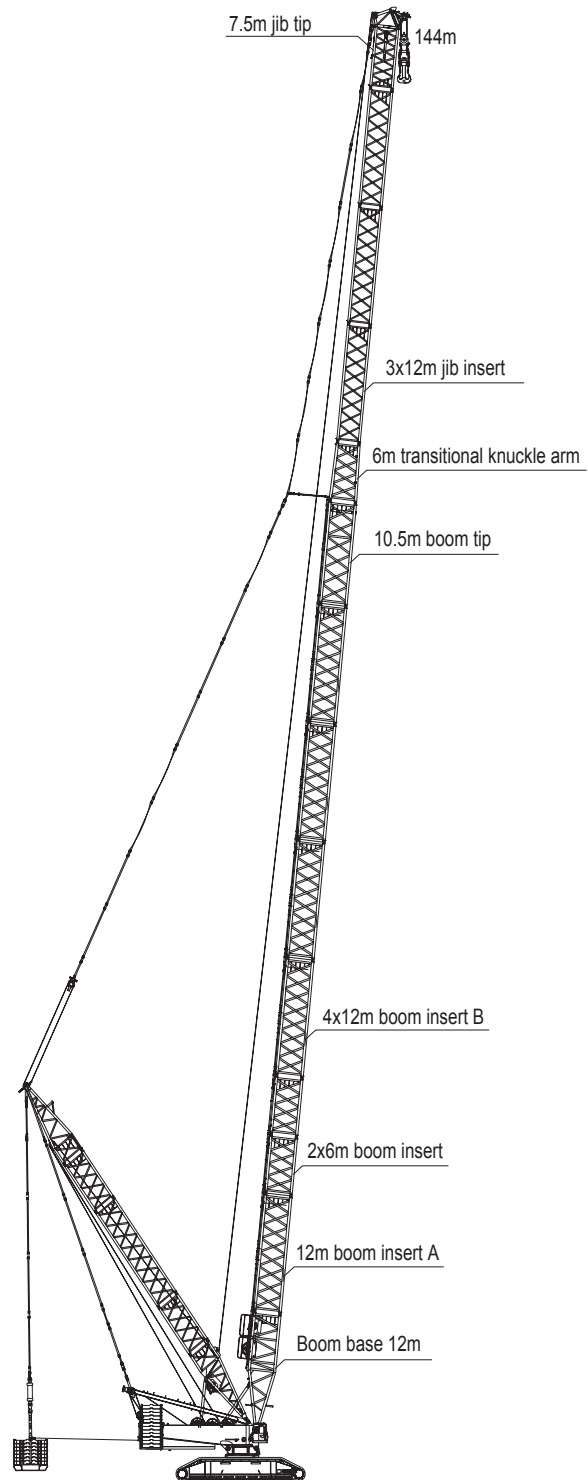





# OPERATING RANGE DIAGRAM OF HJDB OPERATING CONDITION

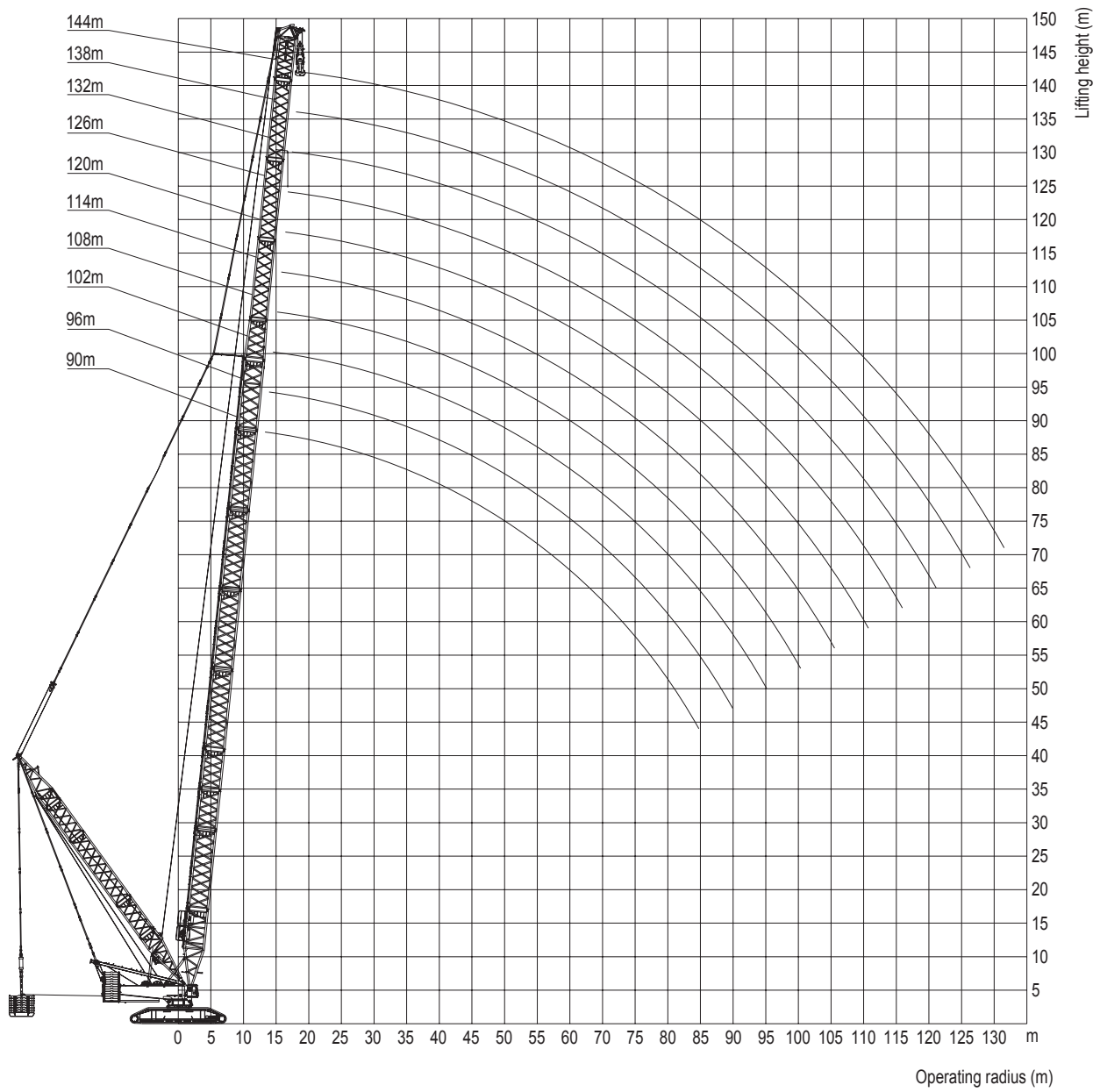

# LOAD CHARTS OF HJDB OPERATING CONDITION

## SCC10000 Crawler Crane – Operating Condition of HJDB24m\_450+250+80

Boom length 90-144m Superlift mast 42m Superlift radius 24m Superlift counterweight 450t Rear counterweight 250t  
Central counterweight 80t Unit:(t)

Boom length (m) Radius(m)	90	96	102	108	114	120	126	132	138	144	Boom length(m) Radius(m)
12	360*	339*									12
13	360*	339*	298*	267*							13
14	360*	339*	298*	267*	242*	211*					14
15	360*	339*	298*	267*	242*	211*	180*	159*			15
16	360*	339*	298*	267*	242*	211*	180*	159*	139*	118*	16
17	360*	339*	298*	267*	242*	211*	180*	159*	139*	117*	17
18	360*	339*	298*	267*	242*	211*	180*	158*	138*	117*	18
19	360*	339*	298*	267*	242*	211*	180*	157*	138*	116*	19
20	360*	339*	298*	267*	242*	211*	179*	156*	137*	116*	20
22	360*	339*	298*	267*	242*	211*	178*	155*	136*	115*	22
24	360*	337*	298*	266*	242*	211*	177*	153*	135*	114*	24
26	360*	334*	297*	265*	242*	211*	176*	152*	134*	113*	26
28	360*	330*	295*	264*	242*	210*	175*	151*	133*	111*	28
30	356*	325*	293*	262*	239*	209*	173*	150*	132*	110*	30
32	344	319*	290*	261*	238*	208*	172*	149*	131*	108*	32
34	333	313	288*	259*	237*	207*	170*	148*	129*	107*	34
36	323	305	285*	256*	236*	205*	168*	147*	128*	105*	36
38	314	297	282	253*	234*	203*	166*	145*	126*	104*	38
40	301	288	278	249*	232*	201*	164*	144*	124*	102*	40
42	287	277	273	245*	230*	199*	162*	142*	122*	100*	42
44	272	265	265	240	228*	196*	160*	141*	119*	99.4*	44
46	259	256	253	235	224	193*	158*	139*	117*	97.9*	46
48	247	244	241	228	221	190*	156*	136*	115*	96.3*	48
52	225	222	219	213	213	185	153*	132*	113*	94.2*	52
56	206	203	200	196	194	179	150*	129*	110*	92.2*	56
60	189	186	184	180	178	171	146*	126*	108*	90.1*	60
65	172	169	166	162	160	159	140	123*	105*	87.6*	65
70	157	153	151	147	145	143	134	119	101*	85*	70
75	139	141	138	134	132	130	126	115	98.9*	82.4*	75
80	115	115	126	123	121	119	117	110	94.8	79.8*	80
85	98.7	97.4	117	113	111	109	107	104	90.6	77.3*	85
90		81.2*	100	101	102	100	98.8	96.9	86.5	74.7	90
95			85.9	91.7	94.6	92.6	90.7	88.9	82.4	72.1	95
100				80.3	84.5	85.6	83.6	81.8	78.3	69.5	100
105					74.2	74.2	74.2	75.3	73.6	67.0	105
110						63.9	63.9	69.6	67.8	63.9	110
115							52.5	59.7	62.5	60.6	115
120								51.5	53.6	55.8	120
125									45.3	47.4	125
130										39.1	130

Description: 1. The actual lifting capacity must be obtained by deducting the weight of lifting hook, hoisting tools, and wire rope wound the lifting hook and boom head from the rated lifting capacity in the table.  
2. The rated hoisting capacities shown in the table are the weights hoisted on a level and hard ground.

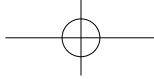

## SF<sub>H</sub>DB OPERATING CONDITION OF FIXED SHORT JIB WITH SUPERLIFT

The fixed short jib is composed of 4.5m jib base, 12m thick boom insert, and 1.5m (60t) arm head.

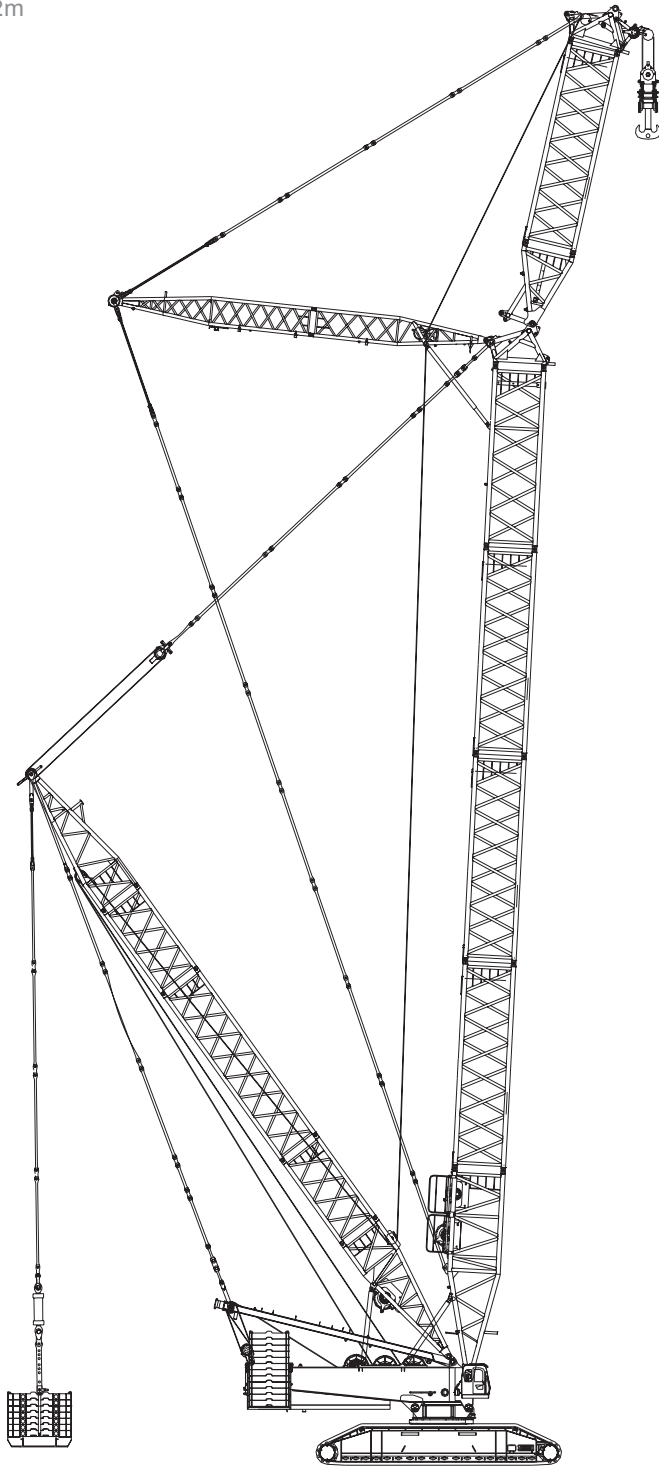

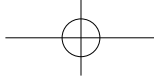

# OPERATING RANGE DIAGRAM OF SF<sub>H</sub>DB OPERATING CONDITION

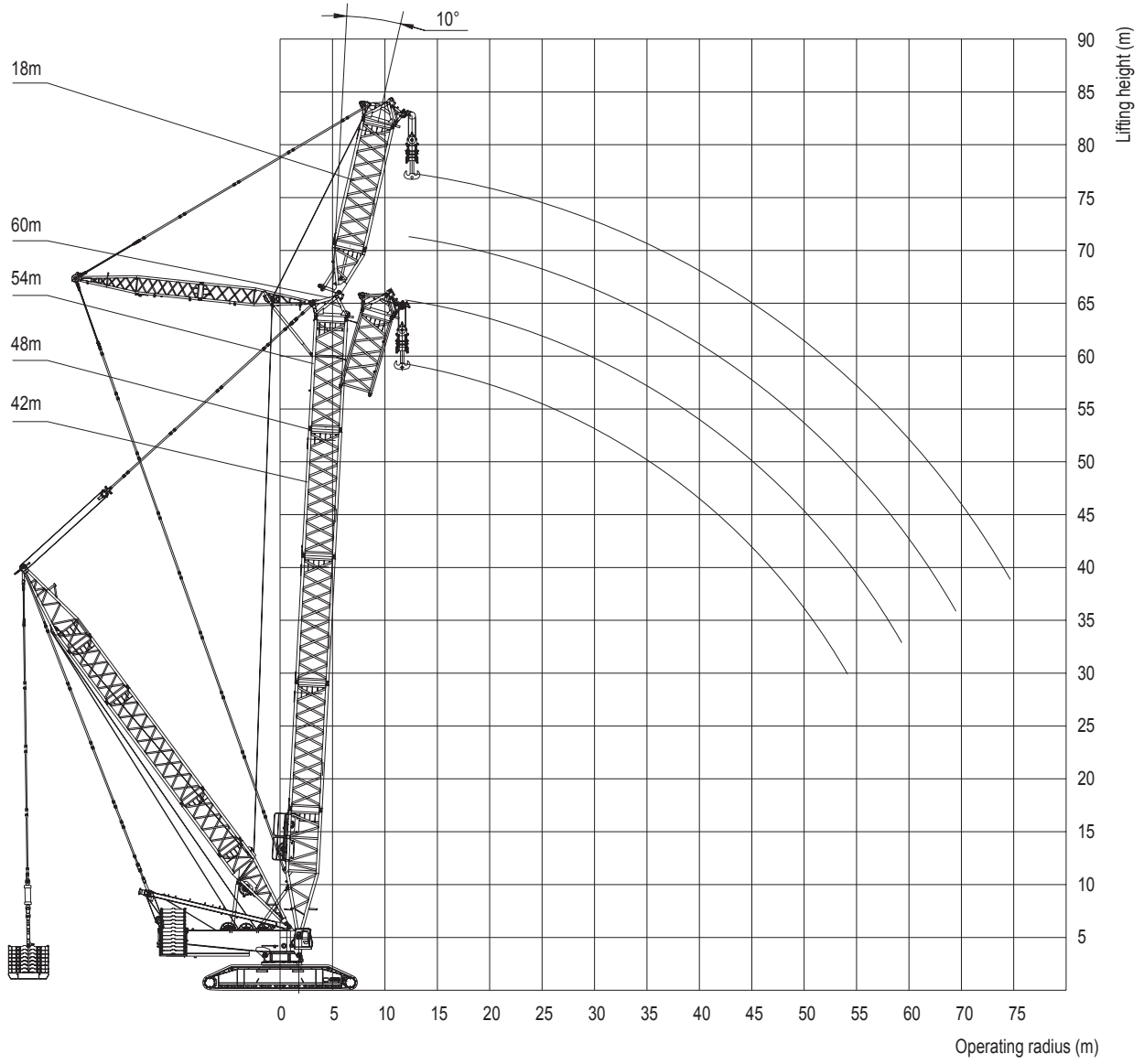

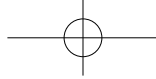

# LOAD CHARTS OF SF<sub>H</sub>DB OPERATING CONDITION

## SCC10000 Crawler Crane – Operating Condition of SFHDB\_24m\_450+250+80

Boom length 42-60m Heavy-duty jib 18m Included angle between boom and jib 13°  
Superlift mast 42m Superlift radius 24m

Unit:(t)

Boom length(m) Radius(m)	42	48	54	60	Boom length (m) Radius(m)
12	618*				12
13	618*	537*	468*	412*	13
14	618*	537*	468*	412*	14
15	618*	537*	468*	412*	15
16	610*	537*	468*	412*	16
17	598*	537*	468*	412*	17
18	577*	537*	468*	412*	18
19	557*	537*	468*	412*	19
20	538*	528*	468*	412*	20
22	505*	498*	468*	412*	22
24	476	472*	468*	412*	24
26	449	448	463	412*	26
28	426	427	437	412	28
30	404	407	404	400	30
34	351	353	349	345	34
38	295	310	306	302	38
42	249	269	272	268	42
46	211	230	240	238	46
50	177	197	208	214	50
54	146	168*	179	188	54
58	*	141*	155	164	58
62	*	116*	131*	141	62
66			110*	121*	66
70				103*	70

Note: the data with \* in the table indicates that the superlift counterweight can not leave the ground under the operating condition.

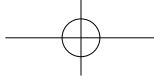

## SF<sub>L</sub>DB OPERATING CONDITION OF LIGHT-DUTY FIXED SHORT JIB WITH SUPERLIFT

The 18m light-duty fixed short jib is composed of 4.5m jib base, 6m reducing arm and 7.5m jib tip.

The boom combination is the same as H operating condition of boom.

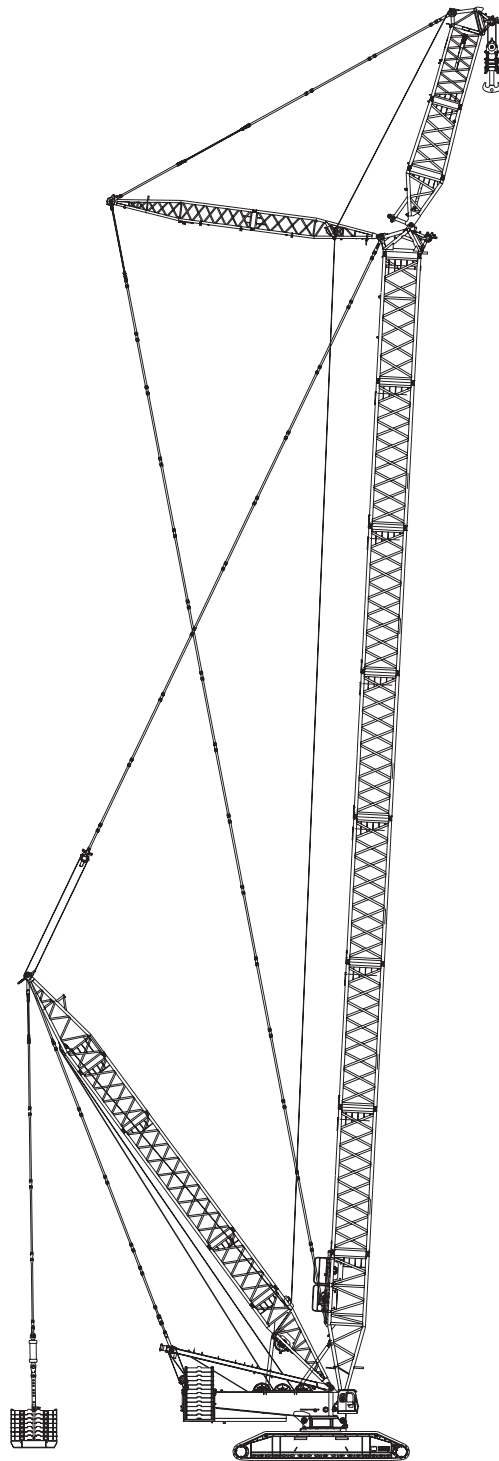



# OPERATING RANGE DIAGRAM OF SF<sub>L</sub>DB OPERATING CONDITION

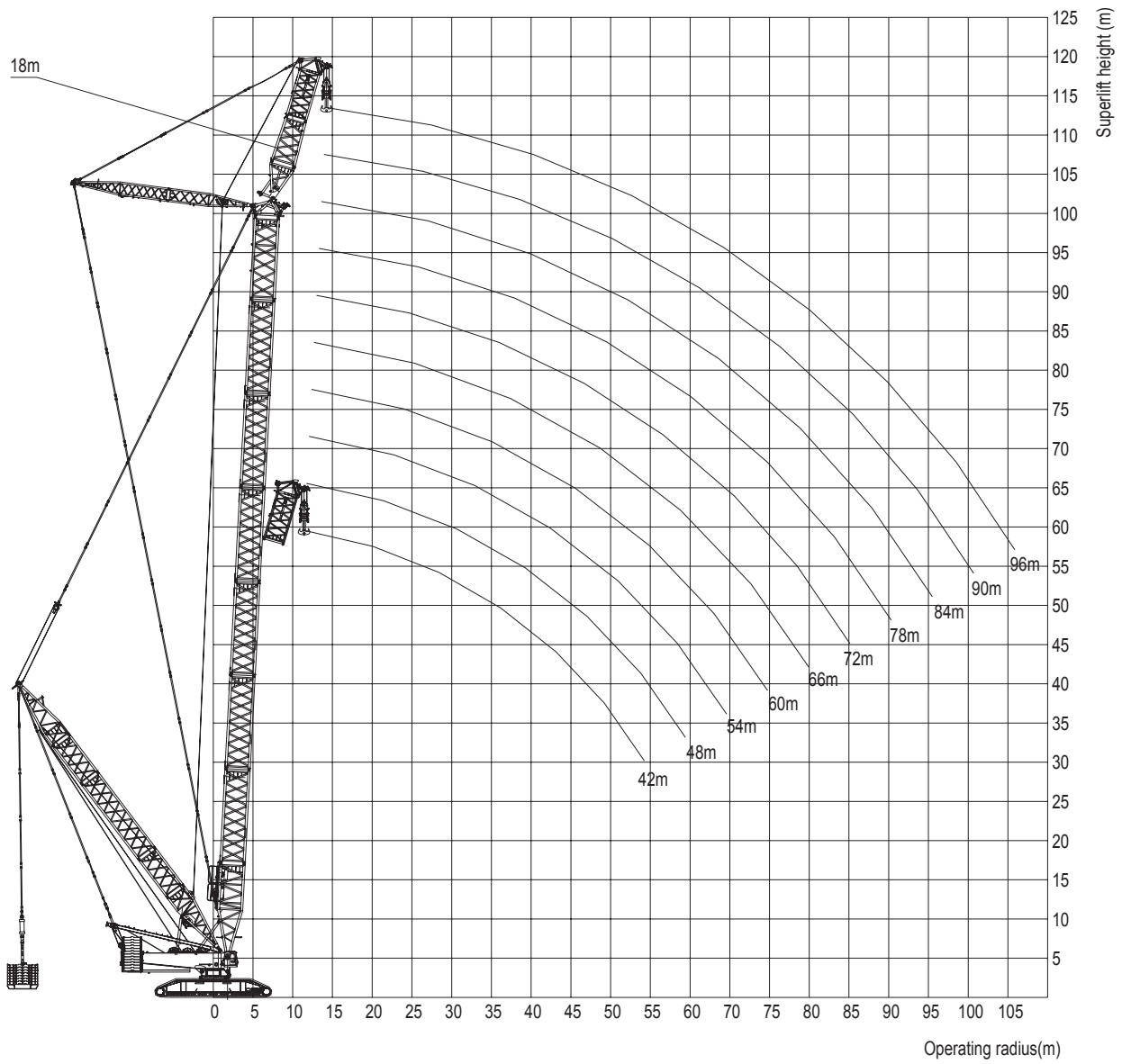

# LOAD CHARTS OF SF<sub>L</sub>DB OPERATING CONDITION

## SCC10000 Crawler Crane – Operating Condition of SF<sub>L</sub>DB24m\_450+250+80

Boom length 42-96m Light-duty jib 18m Included angle between boom and jib 13° Superlift mast 42m Superlift radius 24m Superlift counterweight 450t Rear counterweight 250t Central counterweight 80t Slewing range 0° -360°

Unit:(t)

Boom length(m) Radius(m)	42	48	54	60	66	72	78	84	90	96	Boom length(m) Radius(m)
12	463*										12
13	463*	463*	456*	412*							13
14	463*	463*	456*	412*	363*	318*	279*	246*			14
15	463*	463*	456*	412*	363*	318*	279*	246*	218*	191*	15
16	463*	463*	456*	412*	363*	318*	279*	246*	218*	191*	16
17	463*	463*	456*	412*	363*	318*	279*	246*	218*	191*	17
18	463*	463*	456*	412*	363*	318*	279*	246*	218*	191*	18
19	463*	463*	456*	412*	363*	318*	279*	246*	218*	191*	19
20	463*	463*	456*	412*	363*	318*	279*	246*	218*	191*	20
22	463*	463*	456*	412*	363*	318*	279*	246*	218*	191*	22
24	463*	463*	456*	412*	363*	318*	279*	246*	218*	190*	24
26	458	458	456	412*	363*	318*	279*	246*	218*	190*	26
28	442	445	448	412	363*	318*	279*	246*	217*	189*	28
30	421	421	416	407	363*	318*	279*	245*	215*	188*	30
34	364	366	361	358	352	314	278*	244*	214*	186*	34
38	307	323	318	315	312	306	273	240*	210*	184*	38
42	262	282	283	280	276	273	267	235	205*	179*	42
46	222*	243	252	250	248	245	241	230	201*	175*	46
50	188*	210	220	226	224	221	217	214	196	170*	50
54	158*	179	191	200	202	199	195	192	189	166	54
58		152*	166	176	182	181	178	174	172	161	58
62		126*	142*	154	161	165	162	159	156	153	62
66			120*	133	142	147	148	145	142	139	66
70				113*	123	129	132	133	130	127	70
74					107	113	117	119	119	116	74
78					92.7	98.9	103	105	105	104	78
82						84.7	90.3	93.4	94.9	94.3	82
86							77.8	81.8	83.7	83.7	86
90								70.7	73.6	74.2	90
94									63.6	64.6	94
98									53.5	55.5	98
102										47.0	102

Note: the data with \* in the table indicates that the superlift counterweight can not leave the ground under the operating condition.



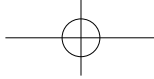

Notes

Area with horizontal dashed lines for notes.

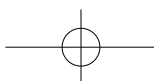
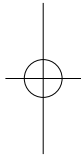
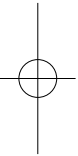



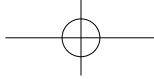

Notes

Area with horizontal dashed lines for notes.

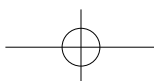
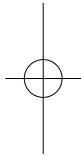
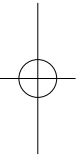



## Quality Changes the World

### **SANY GROUP CO., LTD.**

Address: SANY Industrial Park, Economic and Technological  
Development Zone, Changsha, Hunan, China

Service Hotline: +0086-4006-098-318

E-mail: [crd@sany.com.cn](mailto:crd@sany.com.cn)

For more information, please visit: [www.sanygroup.com](http://www.sanygroup.com)

B05S2ENAM1-SCC10000

