

# AC11-72 Articulating Crane

## Specifications

Number of Extensions	1-Hydraulic	2-Hydraulic	3-Hydraulic	4-Hydraulic	5-Hydraulic
Crane Rating*	71,600 ft-lb (9.9 tm)	71,600 ft-lb (9.9 tm)	71,600 ft-lb (9.9 tm)	71,600 ft-lb (9.9 tm)	71,600 ft-lb (9.9 tm)
Max. Horizontal Reach	19' 6" (5.94 m)	25' 5" (7.74 m)	31' 10" (9.70 m)	38' 9" (11.80 m)	45'2" (13.75 m)
Max Vertical Reach Hydraulic	31' 0" (9.45 m)	37' 1" (11.3 m)	43' 4" (13.2 m)	50' 2" (15.3 m)	56'9" (17.3 m)
Max. Capacity	9,700 lb (4,400 kg)	9,480 lb (4,300 kg)	9,150 lb (4,150 kg)	8,818 lb (4,000 kg)	8,294 (3,770 kg)
Max Capacity @ Max Reach	3,660 lb (1,660 lg)	2,624 lb (1,190 kg)	1,907 lb (865 kg)	1,400 lb (635 kg)	1,045 lb (475 kg)
Crane Weight**	2,400 lb (1,090 kg)	2,640 lb (1,195 kg)	2,840 lb (1,290 kg)	3,040 lb (1,380 kg)	3,476 lb (1,580 kg)

\*Crane rating (ft-lb) is the rated load (lb) x the respective distance (ft) from centerline of rotation with all extensions retracted and the inner and outer booms in a horizontal position, per ANSI B30.22.

\*\*Crane weight does not include outrigger

## Specifications

Outrigger Foot Diameter	6.30" (160 mm)	Optimum Pump Capacity	6.6 gpm (25 L/min)
Crane Storage Height	86" (2,170 mm)	System Pressure	4,420 psi (305 bar)
Mounting Space***	25.20" (640 mm)	Outrigger Extension Span	
Rotational Torque	8,481 ft-lb (1150 daNm)	Standard (manual out, hydraulic down)	11'10" (3.62 m)
Rotation	405°	Weight	330 lb (150 kg)
Oil Reserve Capacity	15.9 gal (60 L)		

\*\*\*Allow an additional 10" between the cab and crane base for swing clearance.

## Minimum Chassis Specifications

Gross Vehicle Weight Rating (GVWR)	28,652 lb
Resistance to Bending Moment (RBM)	588,525 in-lb

## Notes

A. Weight distribution calculations are required to determine final axle loading. The use of service bodies, diesel engines, or longer wheelbase, can increase the minimum chassis requirements. Please contact Auto Crane for details.

B. GAWR (Gross Axle Weight Rating) is the total weight of the vehicle including the (chassis, driveline, occupants, cargo, etc. ) that is allowed by the manufacturer requirements, for the vehicle to go down the road safely. This is a critical factor in purchasing a truck for the crane application. All chassis and crane applications must be tested by engineering and the final assembler to ensure stability per ANSI B30.22.

## System Characteristics

### Rotation System

Our Articulating Cranes utilize a rack and pinion rotation system which provides high torque for demanding applications. The column turns on bushings made of an advanced composite material for long service life. The rotation cylinders are protected by a load holding valve and flow controls to ensure safe and precise operation.

### Cylinder Holding Valves

Flanged load holding valves on hydraulic cylinders provide smooth load control and load holding. In the event of a hose failure, they lock the cylinder in place to prevent uncontrolled crane movement or falling loads.

### Hydraulic Overload System

Providing the Hydraulic Overload protection are main relief and port relief valves, as well as counterbalance valves.

### Hydraulic System

The hydraulic system is open-center as standard. Included on the crane is a hydraulic oil reservoir, return line filter, high-pressure filter(1), and control valve with dual-side controls(2). An optional closed-center valve is available on request.

### Exceptions

- (1) Cranes with manual controls do not have high pressure filter
- (2) Cranes with radio controls do not have dual-side controls



4707 N. Mingo Road  
Tulsa, OK 74117  
918-836-0463  
www.autocrane.com

# AC11-72 Articulating Crane

## Capacity Charts

AC11-72 1 Hydraulic Extension

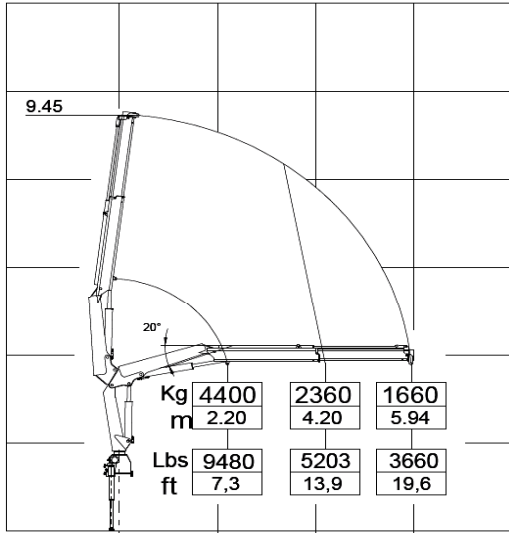

AC11-72 2 Hydraulic Extension

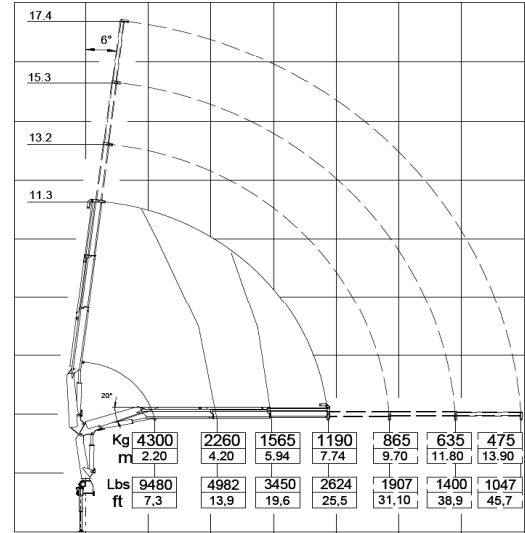

AC11-72 3 Hydraulic Extension

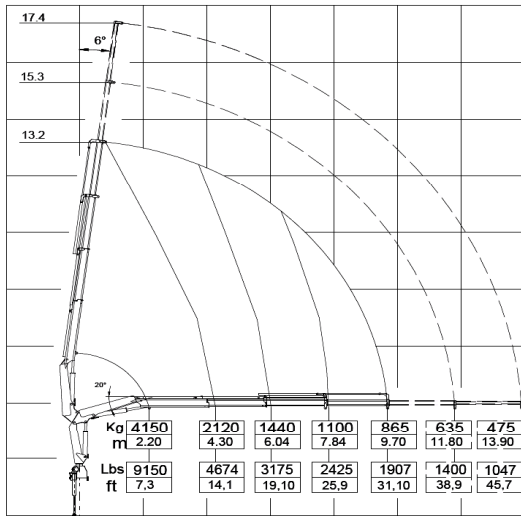

AC11-72 4 Hydraulic Extension

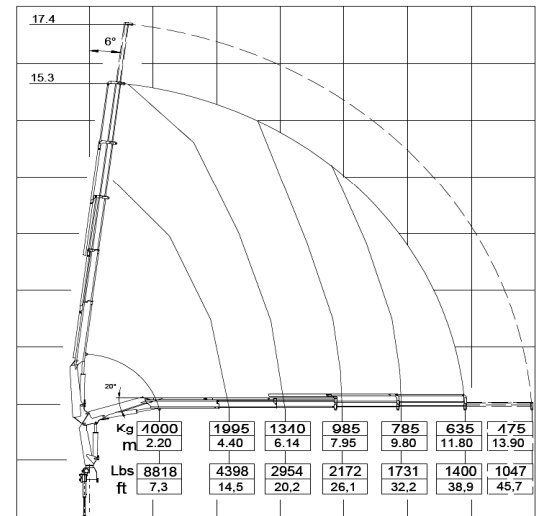

AC11-72 5 Hydraulic Extension

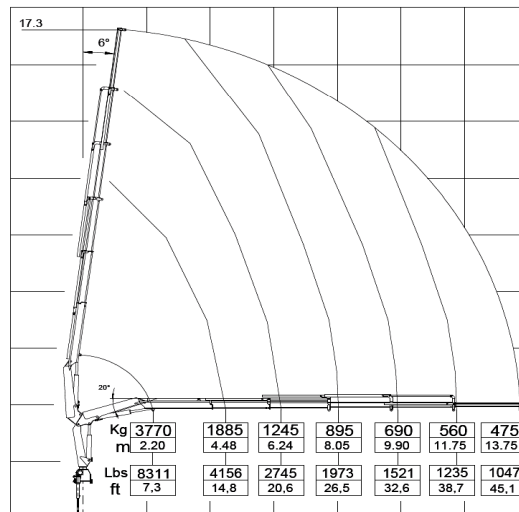

4707 N. Mingo Road  
Tulsa, OK 74117  
918-836-0463  
www.autocrane.com

# AC11-72 Articulating Crane

## Geometric Configurations (Dimensions)

AC11-72 5 Hydraulic Extensions (mm)

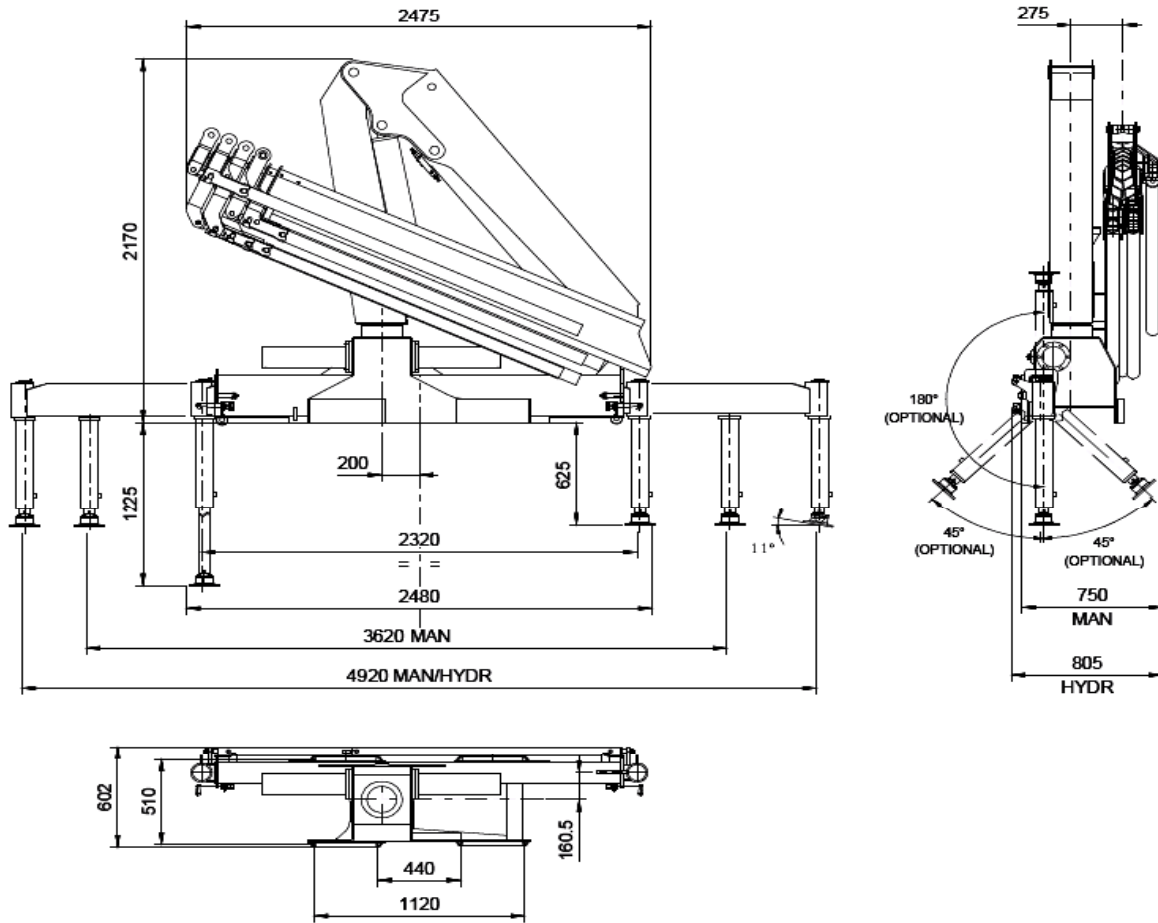

## Special Features (on select models)



4707 N. Mingo Road  
Tulsa, OK 74117  
918-836-0463  
www.autocrane.com

AC11-72