



AT1100

All-terrain hydraulic crane

- Capacity 100 tonnes (110 US tons)
- Maximum on-board tip height 60 metres (197 ft)
- 10 x 8 wheel drive with eight wheel steer
- Maximum speed 70 kph (43.5 mph)
- Optional *telescopic Swingaway 10.00 – 14.60 – 17.70 metres (33 ft – 48 ft – 58 ft). Offsettable at 2°, 15° or 30°



Carrier specifications

Frame	High-strength alloy steel, all-welded box section design with integral outrigger housings and incorporating towing/tie down bracket.	Suspension	Integral hydrogas suspension all round. Hydraulic lockout and automatic levelling system operated from cab.
Outrigger system	Two stage, hydraulic telescopic beam and jack outriggers with integral holding valves. Quick-release outrigger floats 715 mm (28 in) diameter.	Brakes	Dual-line air system operating on all wheels. Spring-applied air-released park brake acting on three rear axles. Engine exhaust brake.
Outrigger controls	Located in the superstructure cab and on both sides of the carrier frame. Push-button electric controls requiring two-handed operation for safety. Crane level indicator adjacent to each set of controls.	Tyres	16.00 x 25 on-off highway radials all round. Tyre inflation kit. Optional *20.50 x 25 on-off highway radials
Engine	Deutz BF10L513, 10-cylinder, turbocharged air-cooled diesel with cold start aid. 16 litres, 294 kw (400 hp) at 2300 rpm. Maximum torque 1460 Nm (1076 lb ft) at 1500 rpm.	Lights	Full lighting including head, tail, braking, reversing, fog, directional and hazard warning lights.
Fuel tank capacity	432 litres (114 US gallons).	Cab	Aluminium with safety glass, acoustically treated, two man, left-hand drive, windscreen wipers and washers, heater and demister, mirrors, full instrumentation and travel controls. Tachograph.
Electrical system	24 v (including starting).	Maximum speed	70 kph (43 mph).
Drive	10 x 4 on-highway, 10 x 8 off-highway, selected from cab.	Gross vehicle weight and axle loads	Machine to standard specification plus *telescopic Swingaway and 5200 kg (11,465 lb) of counterweight. Axle 1: 12,000 kg (26,455 lb) Axle 2: 12,000 kg (26,455 lb) Axle 3: 12,000 kg (26,455 lb) Axle 4: 12,000 kg (26,455 lb) Axle 5: 12,000 kg (26,455 lb) GVW: 60,000 kg (132,275 lb)
Steering	Power assisted, semi-integral type on axles 1, 2, 4 and 5. Steering linkage disconnects to give independent steering of rear axles, and axle 3 raises to allow for co-ordinated or crab steering modes.	Optional *equipment	Superstructure * Auxiliary hoist * Spotlights * Rotating beacon * Hookblocks Carrier * Spare wheel assembly, stowage and handling system * Rotating beacons * Hookblock stowage
Transmission	Engine mounted torque converter and mid-mounted powershift gearbox with front wheel drive disconnect. Eight forward and four reverse speeds.		
Axles	1: Drive-steer 2: Drive-steer 3: Non-drive, non-steer 4: Drive-steer 5: Drive-steer All drive axles are of planetary reduction type, with cross differential locks.		

*Indicates optional equipment.

Superstructure specifications

Boom	12.70 to 39.52 m (42 ft to 130 ft) four-section, full power Trapezoidal main boom consisting of base and three synchronised sections. Cab operated switch allows synchronised two-section extension to 30.58 m (100 ft) with fly section retracted. Telescopic sections slide on adjustable and replaceable Nylatron pads. Telescopic cylinders with integral holding valves. Maximum tip height 42.5 m (139 ft).
Non telescopic offsettable Swingaway extension	10.00 m (33 ft) lattice Swingaway extension, offsettable at 2°, 15°, or 30°. Stows alongside base boom section when not in use. Maximum tip height 52.5 m (172 ft).
Optional *telescopic offsettable Swingaway extension	10.00 to 14.60 m or 17.70 m (33 ft to 48 ft or 58 ft) Swingaway extension with a rectangular roller mounted section which extends/retracts from within the 10.00 m (33 ft) lattice extension. Offsettable 2°, 15° or 30°. Stows alongside base boom section when not in use. Maximum tip height 60.00 m (197 ft).
Boom nose	Six sheaves, mounted on heavy duty tapered roller bearings. Removable pin-type rope guards.
Optional *auxiliary boom nose	Pin-mounted, removable auxiliary boom nose for single line lifting.
Boom elevation	Single hydraulic cylinder with integral holding valve provides elevation from -3° to +80°.
Load-moment indicator and anti-two block system	Standard load moment and anti-two block system with audio-visual warning and control lever lockout to alert operator of impending two-block condition. Electronic display of boom angle, length, radius, tip height, relative load moment, maximum permissible load and load indication is provided.
Cab	Aluminium, acoustically treated, fully enclosed with safety glass, hinged skylight with electric wiper, windscreen wiper, horn, heater, air circulation fan, crane level indicator, lockable sliding door, instrumentation, pilot type crane controls and travel controls.
Swing	Ball-bearing swing circle with 360° continuous rotation. Planetary gearbox with Glideswing, spring-applied multi-disc foot brake and holding brake. Plunger-type house lock operated from the cab. Maximum speed 2.0 rpm.
Counterweight	5200 kg (11,465 lb) counterweight including 1100 kg (2,425 lb) in lieu of auxiliary hoist. Hydraulic removal system. *Optional 7200 kg (15,875 lb) additional counterweight to give a total of 12,400 kg (27,340 lb).
Engine	Deutz BF6L913C six-cylinder turbocharged, air-cooled diesel, 6.1 litres. 141 kw (192 hp) at 2500 rpm. Maximum torque 600 Nm (442 lb ft) at 1700 rpm. Fuel tank capacity 226 litres (60 US gallons)

Electric system 24 V (including starting).

HYDRAULIC SYSTEM

Pumps	Four main gear pumps, combined capacity 518 litres/minute (153 US gallons/minute). Maximum pressure 245 kg/cm ² (3500 psi).
Valves	Precision, four-way, double-acting pilot-operated control valves with four individual valve banks, permitting simultaneous control of multiple crane functions.
Filters	Return line filter with 25 micron rated replaceable cartridge and filter service indicator. Three pressure line filters with 10 micron rated replaceable elements.
Reservoir	864 litres (228 US gallons) capacity. Internal baffles, particle magnet, clean out access and exterior oil level gauge.
Oil cooler	Thermostatically controlled, electric motor driven fan.
Pressure check panel	System pressure test panel with quick-release couplings.

HOIST SPECIFICATIONS

Variable displacement axial piston motor with two position control, driving through planetary gear reduction with integral spring-applied brake provides high line pull and speed ranges. Electronic hoist-drum rotation indicator over lower limit switch.

	Main hoist		*Auxiliary hoist	
	Low Range	High Range	Low Range	High Range
Maximum single line speed				
Bottom layer	58 m/min (190 fpm)	100 m/min (328 fpm)	51 m/min (167 fpm)	120 m/min (394 fpm)
Intermediate layer	66 m/min (216 fpm)	112 m/min (367 fpm)	57 m/min (187 fpm)	135 m/min (443 fpm)
Top layer	73 m/min (239 fpm)	124 m/min (406 fpm)	63 m/min (207 fpm)	149 m/min (489 fpm)
Maximum single line pull				
Bottom layer	12,000 kg (26,460 lb)	4000 kg (8820 lb)	7000 kg (15,435 lb)	3300 kg (7277 lb)
Intermediate layer	10,700 kg (23,594 lb)	3570 kg (7872 lb)	6250 kg (13,781 lb)	2900 kg (6395 lb)
Top layer	9640 kg (21,256 lb)	3220 kg (7100 lb)	5700 kg (12,569 lb)	2700 kg (5954 lb)
Maximum permissible line pull	9250 kg (20,400 lb)		5500 kg (12,125 lb)	
Maximum rope stowage	272 m x 25 mm (892 ft x 1 in)		259 m x 19 mm (850 ft x 3/4 in)	
Standard rope supplied	250 m x 25 mm (820 ft x 1 in)		230 m x 19 mm (755 ft x 3/4 in)	

*Indicates optional item.

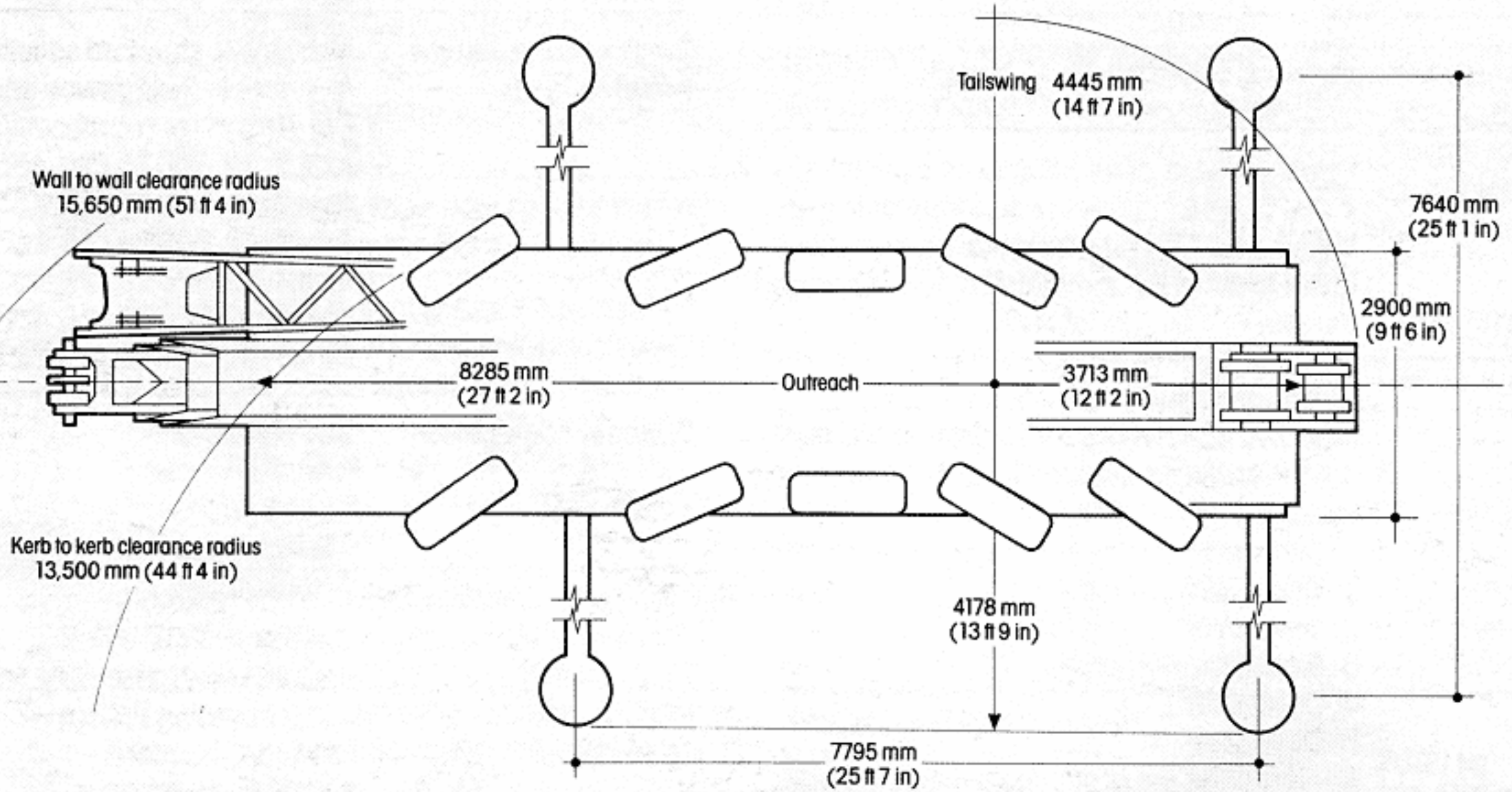
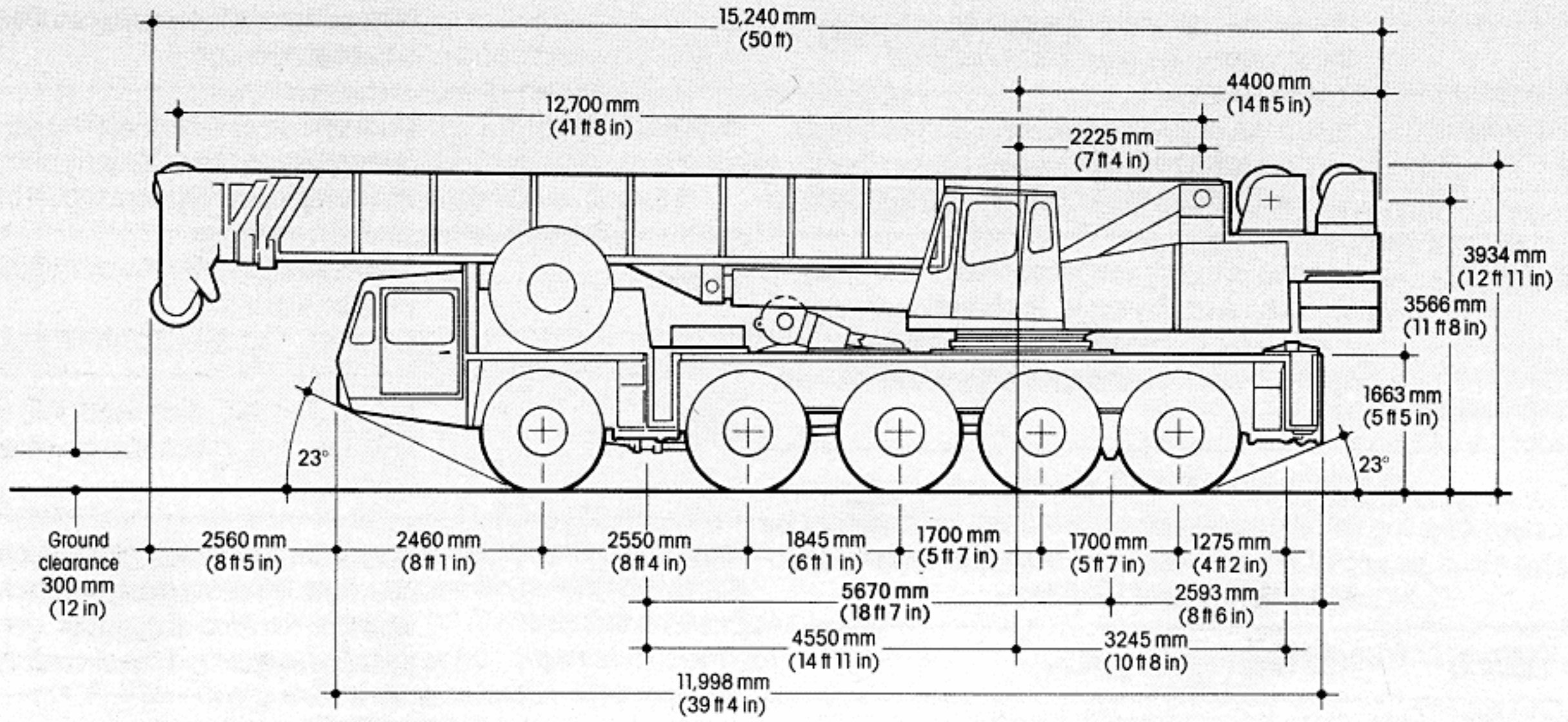

Europe, Africa, Middle East, Indian Sub-continent

Grove
Sunderland, England SR4 6TT
Telephone: 091-5656281
Telex: 53484 CRANES G
Fax: 091-5640442

North and South America, Far East, Australasia, USSR

Grove
Shady Grove, Pennsylvania PA17256, USA
Telephone: (717) 597-8121
Telex: 842308
Fax: (717) 597-4062

Constant improvement and engineering progress make it necessary that the company reserves the right to make specification, equipment and price changes without notice. Illustrations shown may include optional equipment and accessories and may not include all standard equipment. Optional equipment is designated by (*) in specifications folder.
Grove Coles Limited, Registered in England, No 1845 128. Registered Office, Crown Works, Sunderland, England SR4 6TT.