

ALL TERRAIN CRANE

GA

GA-1500N

JAPANESE SPECIFICATIONS

CARRIER MODEL	SPEC. NO.
FAUN RTF120-5	GA-1500N-1-90101

Control No. GA-1500N-1-90101 / JA-03

GA-1500N

CRANE SPECIFICATIONS

CRANE CAPACITY

12.6m Boom	150,000kg	at 2.7m (21part-line, with auxiliary jacks)
16.6m Boom	92,000kg	at 3.5m (12part-line)
20.7m Boom	80,000kg	at 4.0m (10part-line)
24.7m Boom	63,000kg	at 6.0m (8part-line)
28.8m Boom	56,000kg	at 5.0m (7part-line)
32.8m Boom	40,000kg	at 7.0m (5part-line)
36.9m Boom	33,400kg	at 8.0m (5part-line)
40.9m Boom	27,300kg	at 9.0m (4part-line)
45.0m Boom	21,500kg	at 12.0m (4part-line)
49.0m Boom	17,500kg	at 12.0m (4part-line)
53.1m Boom	15,000kg	at 9.0m (3part-line)
56.0m Boom	13,500kg	at 10.0m (3part-line)
Single top	8,000kg	(1part-line)
9.9m Jib	7,000kg	at 73 ° (1part-line)
15.7m Jib	4,400kg	at 75 ° (1part-line)
21.5m Jib	2,800kg	at 75 ° (1part-line)

MAX.LIFTING HEIGHT

Boom	55.5m
Jib	77.0m

MAX.WORKING RADIUS

Boom	52.0m
Jib	56.1m

BOOM LENGTH

12.6m – 56.0m

BOOM EXTENSION

43.4m

BOOM EXTENSION SPEED

43.4m/410s

JIB LENGTH

9.9m – 21.5m

MAIN WINCH SINGLE LINE WINDING SPEED

High speed: 140m/min Low speed: 70m/min (4th layer)

MAIN WINCH HOOK SPEED

High speed: 11.7m/min Low speed: 5.8m/min
(12 part-line)

AUXILIARY WINCH SINGLE LINE WINDING SPEED

High speed: 140m/min Low speed: 70m/min (4th layer)

AUXILIARY WINCH HOOK SPEED

High speed: 140m/min Low speed: 70m/min
(1 part-line)

BOOM ELEVATION ANGLE

-1.7 ° ~ 81.5 °

BOOM ELEVATION SPEED

-1.7 ° ~ 81.5 755s

SWING ANGLE

360 °continue

SWING SPEED

1.4min⁻¹(rpm)

WIRE ROPE

Main Winch

22mm x 263m (Diameter x Length)
Anti-rotate wire rope

Auxiliary Winch

22mm x 165m (Diameter x Length)
Anti-rotate wire rope

HOOK

150t hook (21part-line, With attachment sheave)
50t hook (7part-line)
8t hook (1part-line)

BOOM

6-section hydraulically telescoping boom of box construction

Each stage lock pin type

BOOM EXTENSION

1 double-acting hydraulic cylinders
With flow regulator valve with pressure compensation

JIB

Folding type which stores alongside the boom
3-section hydraulically synchronously telescoping boom
Hydraulic non-stage offset (5 ° ~ 60 °) type

SINGLE TOP

Single sheave. Mounted to main boom head for single line work.

HOIST

Driven by hydraulic variable motor and via planetary gear reducer.

Automatic brake

2 single winches

With flow regulator valve with pressure compensation

BOOM ELEVATION

1 double-acting hydraulic cylinder

With flow regulator valve with pressure compensation

SWING

Hydraulic motor driven planetary gear reducer

Swing bearing

Manual switch brake

Swing free/lock changeover type

OUTRIGGERS

Fully hydraulic H-type

With auxiliary jacks

Slides and jacks each provided with independent operation device.

Fully extended width 8.0m

Middle extended width 7.0m, 5.3m, 4.6m

Slide storing float

ENGINE FOR CRANE

Engine exclusive to upper component operation

Model MITSUBISHI 6D16 - TLEF

Type 4-cycle, 6 in-line cylinder, direct-injection, water-cooled diesel engine with turbo charger (with inter cooler)

Piston displacement 7.545 liters

Max. output 136kW {185PS} at 1,830min⁻¹

Max. torque 744N·m {76.0kgf·m} at 1,600min⁻¹

HYDRAULIC PUMPS

2 variable high-pressure piston pumps and 2 high-pressure gear pumps

HYDRAULIC OIL TANK CAPACITY

1,010 liters

SAFETY DEVICES

Automatic moment limiter (AML)

With working range limiting function

With hook movement amount indicator

Outrigger extension automatic detector (individual detection)

Weight combination automatic detector

Swing range controller

Swing automatic stop device

Boom elevation slow down and stop device

Over-winding cutout device

Dead winding holding device

Level gauge

Hook safety latch

Cable follower

Swing lock

Hydraulic safety valve

Telescopic counterbalance valve

Elevation counterbalance valve

Jack pilot check valve

EQUIPMENT

Counterweight dismount/mount device

Jib extension device

Boom elevation creeping mode setting device

Swing creeping mode setting device

Swing frame dismount/mount device (dismounting/mounting ring)

Boom dismount/mount device

AML external indication lamp

Oil cooler

Air conditioner

FM radio

Hot and cool boxes

Lunch table

Drum monitor

Swing alarm

OPTIONAL EQUIPMENT

TV tuner

Loudspeaker

CARRIER SPECIFICATIONS

MANUFACTURER

FAUN GmbH

CARRIER MODEL

RTF 120-5

ENGINE

Model OM442LA (Benz)

Type 4-cycle, V8-cylinder, direct-injection,
water-cooled turbo diesel engine with inter cooler

Piston displacement 14,618 liters

Max. output 370kW (503PS) at 2,100rpm

Max. torque 2,020N-m (206kgf-m) at 1,100 – 1,600rpm

TRANSMISSION

Fully automatic

5-forward and 1-reverse speeds

Sub-transmission provided.

CLUTCH

Torque converter provided.

Automatic lock-up mechanism provided.

DRIVING METHOD

10 x 6

10 x 6 --- Off load (with def-lock mechanism)

AXLE (all axles)

Full-floating type

SUSPENSION (all axles)

Hydraulic pneumatic suspension

Stroke: +149mm/-113mm

STEERING

Type: Left-side handle

Fully hydraulic power steering

2 circuits

Emergency power steering

Mode: Normal (6 front wheels)

Clamp (10 wheels)

Crab (10 wheels)

Rear steering (4 rear wheels)

BRAKE SYSTEM

Service Brake

Air brake on all wheels

2 circuits

Parking Brake

4th and 5th axles (4-wheel) spring brake for public
thoroughfare traveling

(3rd, 4th and 5th axles (6-wheel) spring brake for on-
site traveling)

Emergency Brake

Works by applying the parking brake

Auxiliary Brake

Flow type retarder (transmission built-in)

Exhaust brake

ELECTRIC SYSTEM

24 V DC. 2 batteries of 12V–170Ah

FUEL TANK CAPACITY

570 liters

CAB

Two-man type

TIRES

445/95R25 177E ROAD (all wheels)

WHEEL

11.00–25 (all wheels)

STANDARD EQUIPMENT

Air conditioner

FM radio

Mud guard

Centralized lubrication unit

Bed for napping

OPTIONAL EQUIPMENT

Back monitor

GENERAL DATA

DIMENSIONS (CARRIER ONLY)

Overall length 12,140mm

Overall width 3,000mm

Overall height 2,755mm

Wheel base 2,600mm + 1,700mm + 1,750mm +

1,650mm = 7,700mm

Tread 2,557mm

WEIGHTS (CARRIER ONLY)

Gross vehicle weight

Total 34,180kg (Two-man type)

Front: 1st + 2nd axles 17,280kg

Rear: 3rd axle 1,400kg

4th + 5th axles 15,500kg

PERFORMANCE

Max. traveling speed 70km/h

Gradeability (tan) 0.70

Min. turning radius

6-wheel steering 11.9m

10-wheel steering 8.5m

Note:

1. The swing jib of this crane must be removed and transported separately from the carrier when running on public roads.
2. This crane is covered by Class C Conditions under the Basic Running Conditions of the Road Traffic Act.

TOTAL RATED LOADS

[BOOM]

Performance A (Counterweight 28 t, Outrigger extension width 8.0 m)

Performance blocks		Unit: ton															
Performance numbers		1	2	3	4	5	6	7	8	9	10	11	12	13	14	15	16
Boom length (m)	Working radius (m)	12.6m	16.6m	20.7m	24.7m	28.8m	32.8m	36.9m	40.9m	45.0m	49.0m	53.1m	20.7m	24.7m	28.8m	32.8m	36.9m
		2.7	150.0	120.0	40.0	36.2	38.8							40.0	40.0		
3.0	130.0	114.9	40.0	34.6	37.0								40.0	40.0			
3.5	117.8	105.4	40.0	32.3	34.4	30.3							40.0	40.0	40.0		
4.0	105.2	97.3	40.0	30.2	32.1	28.2							40.0	40.0	40.0	40.0	
4.5	90.2	82.3	39.1	28.4	30.1	26.4	28.5						40.0	40.0	40.0	40.0	38.2
5.0	82.3	82.3	37.3	26.8	28.3	24.7	26.8	24.2					40.0	40.0	40.0	40.0	38.2
6.0	67.9	67.9	34.1	24.0	25.2	22.0	24.0	23.4	20.7				37.8	40.0	40.0	38.2	33.4
7.0	57.5	57.5	31.4	21.8	22.8	19.7	21.7	20.9	20.7	17.9			34.3	37.7	40.0	38.2	33.4
8.0	49.6	49.6	29.2	19.9	20.7	17.9	19.8	18.9	20.5	17.9	16.0		31.3	34.4	38.4	38.2	33.4
9.0	43.3	43.3	27.3	18.3	19.0	16.3	18.1	17.2	18.7	17.9	16.0	15.0	28.9	31.5	35.4	38.2	31.8
10.0	37.3	37.3	25.7	17.0	17.5	15.0	16.7	15.8	17.2	17.9	16.0	14.9	26.7	29.1	32.8	35.9	29.2
12.0			23.1	14.8	15.2	12.8	14.4	13.4	14.7	15.8	16.0	14.5	23.3	25.2	28.6	31.5	25.0
14.0			20.5	13.1	13.3	11.2	12.7	11.6	12.8	13.8	14.8	13.3	20.7	22.2	25.3	26.7	21.7
16.0			11.8	11.9	9.9	11.2	10.2	11.3	12.2	13.1	12.2	12.2	18.7	19.8	22.1	21.6	19.1
18.0			10.9	10.7	8.8	10.1	9.0	10.0	10.9	11.8	11.1	11.1	15.4	17.9	18.4	17.9	17.0
20.0				9.8	7.9	9.1	8.0	9.0	9.8	10.6	10.2		15.7	15.5	15.0	14.6	
22.0				9.1	7.2	8.3	7.2	8.1	8.9	9.7	9.4		11.8	11.8	13.3	12.8	12.3
24.0					6.6	7.6	6.5	7.4	8.1	8.8	8.6				11.4	11.0	10.5
26.0					6.1	7.0	5.9	6.7	7.4	8.1	8.0				9.0	9.5	9.0
28.0						6.4	5.4	6.2	6.8	7.5	7.4				8.2	8.2	7.8
30.0						6.0	5.0	5.7	6.2	6.9	6.9				6.7	6.7	6.6
32.0							4.6	5.3	5.7	6.4	6.4						5.6
34.0							4.3	4.9	5.2	5.9	5.8						4.7
36.0							4.6	4.8	5.4	5.0	5.0						
38.0							4.3	4.4	4.7	4.4	4.3						
40.0							4.1	4.1	3.7								
42.0								3.9		3.6	3.1						
44.0									3.1	2.6							
46.0									2.7	2.2							
48.0										1.8							
50.0										1.4							
The maximum load without a pin	50.6	50.6	40.0	25.7	38.8	25.4	28.5	24.2	20.7	17.9	16.0	15.0	40.0	40.0	40.0	38.2	28.4
(°)	0 ~ 81.5	0 ~ 81.5	0 ~ 81.5	0 ~ 81.5	0 ~ 81.5	0 ~ 81.5	0 ~ 81.5	0 ~ 81.5	0 ~ 81.5	0 ~ 81.5	5 ~ 81.5	8 ~ 81.5	0 ~ 81.5	0 ~ 81.5	0 ~ 81.5	0 ~ 81.5	2 ~ 81.5
		Boom stage telescoping condition (telescoping rate %)															
2nd boom	0	0	0	0	0	0	0	0	0	0	47	93	0	0	0	47	93
3rd boom	0	0	0	0	0	0	0	0	0	47	93	93	0	0	47	47	47
4th boom	0	0	0	0	0	0	47	93	93	93	93	93	0	47	47	47	47
5th boom	0	0	0	0	47	93	93	93	93	93	93	93	47	47	47	47	47
6th boom	0	0	47	93	93	93	93	93	93	93	93	93	47	47	47	47	47
Number of part lines	21	21	5	5	5	4	4	4	4	4	4	3	5	5	5	5	5

Note) Values with are for when the auxiliary jacks are used.

Performance A (Counterweight 28 t, Outrigger extension width 8.0 m)

Performance blocks	Unit: ton														
	3	4	5	6	7	8	9	10	11	11	32				
Performance numbers	17	19	20	21	22	23	24	25	26	27	28	29	30	31	32
Boom length (m)	32.8m	40.9m	40.9m	45.0m	45.0m	49.0m	56.0m	16.6m	20.7m	20.7m	24.7m	28.8m	24.7m	28.8m	32.8m
Working radius (m)	2.7							92.0	80.0	63.0	63.0		40.0		
3.0								92.0	80.0	63.0	63.0		40.0		
3.5								92.0	80.0	63.0	63.0	56.0	40.0	40.0	
4.0								88.0	80.0	63.0	63.0	56.0	40.0	40.0	
4.5	32.0							82.0	78.2	63.0	63.0	56.0	40.0	40.0	40.0
5.0	32.0	28.5						76.0	72.8	63.0	63.0	56.0	40.0	40.0	40.0
6.0	30.3	28.5	22.2	27.3				66.0	63.9	63.0	63.0	50.1	40.0	40.0	40.0
7.0	27.7	28.5	22.2	27.3	21.5	19.8		57.9	56.9	58.0	56.4	45.0	40.0	40.0	40.0
8.0	25.4	27.2	22.2	27.3	21.5	19.8	17.5	50.0	49.8	50.9	50.5	40.8	40.0	40.0	37.3
9.0	23.5	25.3	21.1	27.3	21.5	19.8	17.5	43.7	43.6	44.6	44.3	37.2	40.0	40.0	34.0
10.0	21.8	23.5	19.6	27.1	21.5	19.8	17.5	38.7	38.5	39.5	39.2	34.2	38.3	40.0	31.2
12.0	19.1	20.7	17.1	23.1	21.5	18.5	17.5	30.4	30.2	31.3	31.0	29.3	32.3	31.9	26.6
14.0	16.9	18.4	15.2	20.0	18.9	16.3	17.3	11.7	19.2	24.0	25.2	24.8	24.4	26.3	25.8
16.0	15.2	16.6	13.6	17.5	16.5	14.5	15.4	10.8		19.0	20.2	19.8	19.4	21.2	20.8
18.0	13.8	15.1	12.3	15.5	14.6	13.0	13.9	9.9		13.0	14.0	16.2	15.7	17.5	17.1
20.0	12.6	13.8	11.2	13.7	12.9	11.7	12.3	9.1				13.4	13.0	14.7	13.8
22.0	11.6	12.8	10.2	12.3	11.5	10.5	11.0	8.3				9.9	10.8	10.9	12.0
24.0	10.7	11.6	9.4	10.5	10.2	9.5	9.8	7.7				9.0	9.0	10.2	9.8
26.0	10.0	10.1	8.7	9.0	9.2	8.7	8.8	7.2					6.9	8.0	8.3
28.0	9.3	8.8	8.1	7.8	7.9	7.9	8.0	6.7							6.9
30.0	7.5	7.8	7.5	6.6	6.8	7.3	7.2	6.3							5.6
32.0	6.8	6.8	7.0	5.6	5.8	6.6	6.2	5.8							
34.0	5.6	6.3	4.7	4.9	5.8	5.8	5.3	5.6							
36.0	5.6	5.6	3.9	4.1	5.0	4.5	5.0								
38.0	4.7	4.7	3.3	3.5	4.3	3.8	4.3								
40.0				2.9	3.7	3.2	3.7								
42.0				2.3	3.2	2.6	3.2								
44.0					2.2	2.7	2.7								
46.0					1.8	2.2	2.1								
48.0						1.8	1.8								
50.0							1.4								
The maximum load without a pin	32.0	28.5	27.3	21.5	19.8	17.5	13.5	44.3	41.2	42.3	40.0	30.5	39.3	37.8	29.5
(°)	0~81.5	0~81.5	1~81.5	5~81.5	6~81.5	4~81.5	7~81.5	10~81.5	10~81.5	10~81.5	10~81.5	1~81.5	10~81.5	10~81.5	2~81.5
Boom stage telescoping condition (telescoping rate %)															
2nd boom	0	47	47	93	93	47	93	100	0	47	0	47	93	0	47
3rd boom	47	47	47	93	93	93	93	100	47	47	47	47	47	47	47
4th boom	47	47	47	93	93	93	93	100	0	0	47	47	47	47	47
5th boom	47	47	93	47	47	93	93	100	0	0	0	0	0	47	47
6th boom	93	93	93	47	47	47	100	0	0	0	0	0	0	0	0
Number of part lines	4	4	4	4	4	4	4	3	12	10	8	8	7	5	5

Performance B (Counterweight 23 t, Outrigger extension width 8.0 m)
(Counterweight 28 t, Outrigger extension width 7.0 m)

Performance blocks	Unit: ton															
	1								2							
Performance numbers	1	2	3	4	5	6	7	8	9	10	11	12	13	14	15	16
Boom length (m)	12.6m	16.6m	20.7m	24.7m	28.8m	32.8m	36.9m	40.9m	45.0m	49.0m	53.1m	20.7m	24.7m	28.8m	32.8m	36.9m
Working radius (m)	2.7	4.0	5.3	6.6	8.0	9.3	10.7	12.0	13.4	14.7	16.0	17.4	18.7	20.0	21.4	22.7
	120.0	40.0	36.2	38.8								40.0	40.0			
	114.9	40.0	34.6	37.0								40.0	40.0			
	105.4	40.0	32.3	34.4	30.3							40.0	40.0	40.0		
	96.8	40.0	30.2	32.1	28.2							40.0	40.0	40.0	40.0	
	88.7	39.1	28.4	30.1	26.4	28.5						40.0	40.0	40.0	38.2	
	79.9	37.3	26.8	28.3	24.7	26.8	24.2					40.0	40.0	40.0	38.2	33.4
	66.0	34.1	24.0	25.2	22.0	24.0	23.4	20.7				37.8	40.0	40.0	38.2	33.4
	55.8	31.4	21.8	22.8	19.7	21.7	20.9	20.7	17.9			34.3	37.7	40.0	38.2	33.4
	48.1	29.2	19.9	20.7	17.9	19.8	18.9	20.5	17.9	16.0		31.3	34.4	38.4	38.2	33.4
	42.0	27.3	18.3	19.0	16.3	18.1	17.2	18.7	17.9	16.0	15.0	28.9	31.5	35.4	38.2	31.8
	32.3	25.7	17.0	17.5	15.0	16.7	15.8	17.2	17.9	16.0	14.9	26.7	29.1	32.8	35.9	29.2
		23.1	14.8	15.2	12.8	14.4	13.4	14.7	15.8	16.0	14.5	23.3	25.2	28.6	31.1	25.0
		20.5	13.1	13.3	11.2	12.7	11.6	12.8	13.8	14.8	13.3	20.7	22.2	24.9	24.3	21.7
			11.8	11.9	9.9	11.2	10.2	11.3	12.2	13.1	12.2	18.7	19.8	20.1	19.6	19.1
			10.9	10.7	8.8	10.1	9.0	10.0	10.9	11.8	11.1	15.4	16.8	16.6	16.2	15.7
				9.8	7.9	9.1	8.0	9.0	9.8	10.6	10.2		14.2	14.0	13.5	13.1
				9.1	7.2	8.3	7.2	8.1	8.9	9.7	9.4		11.8	11.9	11.4	11.0
					6.6	7.6	6.5	7.4	8.1	8.8	8.6			10.2	9.7	9.3
					6.1	7.0	5.9	6.7	7.4	8.1	8.0			8.9	8.4	7.9
						6.4	5.4	6.2	6.8	7.5	7.4					
						6.0	5.0	5.7	6.2	6.9	6.7					
							4.6	5.3	5.7	6.1	5.7					
							4.3	4.9	5.2	5.3	4.9					
							4.3	4.8	4.8	4.6	4.2					
							4.3	4.3	4.3	3.9	3.5					
									3.7	3.4	2.9					
									3.2	2.9	2.4					
										2.4	1.9					
											2.0	1.5				
												1.2				
The maximum load without a pin	50.6	40.0	25.7	38.8	25.4	28.5	24.2	20.7	17.9	16.0	15.0	40.0	40.0	40.0	38.2	28.4
(°)	0 ~ 81.5	10 ~ 81.5	10 ~ 81.5	10 ~ 81.5	10 ~ 81.5	10 ~ 81.5	10 ~ 81.5	10 ~ 81.5	2 ~ 81.5	5 ~ 81.5	14 ~ 81.5	0 ~ 81.5	10 ~ 81.5	10 ~ 81.5	0 ~ 81.5	12 ~ 81.5
2nd boom	0	0	0	0	0	0	0	0	0	47	93	0	0	0	47	93
3rd boom	0	0	0	0	0	0	0	47	93	93	93	0	0	47	47	47
4th boom	0	0	0	0	0	47	93	93	93	93	93	0	47	47	47	47
5th boom	0	0	0	47	93	93	93	93	93	93	93	47	47	47	47	47
6th boom	0	47	93	93	93	93	93	93	93	93	93	47	47	47	47	47
Number of part lines	21	5	5	5	5	4	4	4	4	4	3	5	5	5	5	5

Performance B (Counterweight 23 t, Outrigger extension width 8.0 m)
(Counterweight 28 t, Outrigger extension width 7.0 m)

Performance blocks	Unit: ton															
	17	18	19	20	21	22	23	24	25	26	27	28	29	30	31	32
Performance numbers																
Boom length (m)	32.8m	36.9m	40.9m	40.9m	45.0m	45.0m	49.0m	56.0m	16.6m	20.7m	20.7m	24.7m	28.8m	24.7m	28.8m	32.8m
Working radius (m)	2.7								92.0	80.0	63.0	63.0		40.0		
3.0									92.0	80.0	63.0	63.0		40.0		
3.5									86.5	80.0	63.0	63.0	56.0	40.0	40.0	
4.0									80.2	78.2	63.0	63.0	56.0	40.0	40.0	40.0
4.5	32.0								74.8	72.8	63.0	63.0	56.0	40.0	40.0	40.0
5.0	32.0	28.5							65.7	63.9	63.0	63.0	50.1	40.0	40.0	40.0
6.0	30.3	28.5	22.2	27.3	21.5	19.8			56.2	56.1	57.1	56.4	45.0	40.0	40.0	40.0
7.0	27.7	28.5	22.2	27.3	21.5	19.8			48.5	48.3	49.4	49.0	40.8	40.0	40.0	37.3
8.0	25.4	27.2	22.2	27.3	21.5	19.8	17.5		42.4	42.3	43.3	42.9	37.2	40.0	40.0	34.0
9.0	23.5	25.3	21.1	27.3	21.5	19.8	17.5	13.5	37.0	36.8	37.9	37.6	34.2	38.5	31.2	
10.0	21.8	23.5	19.6	27.1	21.5	19.8	17.5	12.6	28.5	28.3	29.6	29.2	28.7	30.7	30.3	26.6
12.0	19.1	20.7	17.1	23.1	21.5	18.5	17.5	11.7	19.2	21.6	22.9	22.5	22.0	23.9	23.5	23.0
14.0	16.9	18.4	15.2	20.0	18.9	16.3	17.3	10.8		17.1	18.2	17.8	17.4	19.2	18.8	18.3
16.0	15.2	16.6	13.6	17.5	16.5	14.5	15.4	9.9		13.0	14.0	14.5	14.0	15.8	15.4	14.9
18.0	13.8	15.1	12.3	15.5	14.6	13.0	13.9	9.1				11.9	11.5	13.2	12.7	12.3
20.0	12.6	13.8	11.2	13.0	12.9	11.7	12.3	8.3				9.9	9.4	10.9	10.7	10.2
22.0	11.6	12.1	10.2	11.0	11.2	10.5	11.0	8.3					7.7		9.0	8.6
24.0	10.7	10.4	9.4	9.3	9.5	8.7	8.4	7.7					6.2		7.7	7.1
26.0	9.4	9.0	8.7	7.9	8.1	8.7	8.4	7.2								
28.0	8.3	7.8	8.1	6.7	6.9	7.6	7.2	6.7								
30.0	7.3	6.8	7.1	5.6	5.8	6.6	6.1	6.3								
32.0		5.9	6.2	4.6	4.8	5.7	5.2	5.8								
34.0		5.1	5.4	3.8	4.0	4.9	4.4	4.9								
36.0			4.7	3.1	3.3	4.1	3.6	4.2								
38.0			4.1	2.5	2.6	3.5	3.0	3.5								
40.0				2.1	2.1	2.9	2.4	2.9								
42.0					1.6	2.5	1.9	2.4								
44.0							1.5	2.0								
46.0							1.1	1.5								
48.0								1.2								
The maximum load without a pin	32.0	28.5	22.2	27.3	21.5	19.8	17.5	13.5	44.3	41.2	42.3	40.0	30.5	39.3	37.8	29.5
(°)	0~81.5	0~81.5	1~81.5	5~81.5	6~81.5	4~81.5	7~81.5	25~81.5	0~81.5	0~81.5	0~81.5	0~81.5	1~81.5	0~81.5	0~81.5	2~81.5
Boom stage telescoping condition (telescoping rate %)																
2nd boom	0	47	47	93	93	47	93	100	0	47	0	47	93	0	47	93
3rd boom	47	47	47	93	93	93	93	100	47	47	47	47	47	47	47	47
4th boom	47	47	47	93	93	93	93	100	0	0	47	47	47	47	47	47
5th boom	47	47	93	47	47	93	93	100	0	0	0	0	0	47	47	47
6th boom	93	93	93	47	47	47	47	100	0	0	0	0	0	0	0	0
Number of part lines	4	4	4	4	4	4	4	3	12	10	8	8	7	5	5	5

Performance C (Counterweight 23 t, Outrigger extension width 7.0 m)

Performance blocks	2															
	1	2	3	4	5	6	7	8	9	10	11	12	13	14	15	16
Performance numbers	12.6m	16.6m	20.7m	24.7m	28.8m	32.8m	36.9m	40.9m	45.0m	49.0m	53.1m	20.7m	24.7m	28.8m	32.8m	36.9m
Boom length (m)	110.4	40.0	36.2	38.8								40.0	40.0			
Working radius (m)	2.7											40.0	40.0			
3.0	104.4	40.0	34.6	37.0								40.0	40.0			
3.5	95.8	40.0	32.3	34.4	30.3							40.0	40.0	40.0		
4.0	87.5	40.0	30.2	32.1	28.2							40.0	40.0	40.0		
4.5	80.2	39.1	28.4	30.1	26.4	28.5						40.0	40.0	40.0	38.2	
5.0	73.7	37.3	26.8	28.3	24.7	26.8	24.2					40.0	40.0	40.0	38.2	33.4
6.0	63.1	34.1	24.0	25.2	22.0	24.0	23.4	20.7				37.8	40.0	40.0	38.2	33.4
7.0	54.7	31.4	21.8	22.8	19.7	21.7	20.9	20.7	17.9			34.3	37.7	40.0	38.2	33.4
8.0	48.0	29.2	19.9	20.7	17.9	19.8	18.9	20.5	17.9	16.0		31.3	34.4	38.4	38.2	33.4
9.0	42.0	27.3	18.3	19.0	16.3	18.1	17.2	18.7	17.9	16.0	15.0	28.9	31.5	35.4	38.2	31.8
10.0	29.3	25.7	17.0	17.5	15.0	16.7	15.8	17.2	17.9	16.0	14.9	26.7	29.1	32.8	35.9	29.2
12.0		23.1	14.8	15.2	12.8	14.4	13.4	14.7	15.8	16.0	14.5	23.3	25.2	28.6	30.5	25.0
14.0		20.5	13.1	13.3	11.2	12.7	11.6	12.8	13.8	14.8	13.3	20.7	22.2	24.0	23.5	21.7
16.0			11.8	11.9	9.9	11.2	10.2	11.3	12.2	13.1	12.2	18.7	19.4	19.2	18.7	18.2
18.0			10.9	10.7	8.8	10.1	9.0	10.0	10.9	11.8	11.1	15.4	15.9	15.7	15.2	14.7
20.0				9.8	7.9	9.1	8.0	9.0	9.8	10.6	10.2		13.3	13.1	12.6	12.1
22.0				9.1	7.2	8.3	7.2	8.1	8.9	9.7	9.4		11.2	11.0	10.6	10.1
24.0					6.6	7.6	6.5	7.4	8.1	8.8	8.6		9.4	9.4	8.9	8.5
26.0					6.1	7.0	5.9	6.7	7.4	8.1	8.0		8.1	8.1	7.6	7.1
28.0						6.4	5.4	6.2	6.8	7.2	6.9				6.5	5.9
30.0						6.0	5.0	5.7	6.2	6.3	6.0				5.4	4.8
32.0							4.6	5.3	5.7	5.4	5.0					3.9
34.0							4.3	4.9	5.0	4.6	4.2					3.1
36.0								4.6	4.3	3.9	3.5					
38.0								4.1	3.7	3.3	2.9					
40.0									3.1	2.8	2.3					
42.0									2.7	2.3	1.8					
44.0										1.9	1.4					
46.0										1.5						
The maximum load without a pin	50.6	40.0	25.7	38.8	25.4	28.5	24.2	20.7	17.9	16.0	15.0	40.0	40.0	40.0	38.2	28.4
(°)	0~81.5	0~81.5	0~81.5	0~81.5	0~81.5	0~81.5	0~81.5	0~81.5	2~81.5	15~81.5	28~81.5	0~81.5	0~81.5	0~81.5	0~81.5	12~81.5
Telescoping rate (%)	Boom stage telescoping condition (telescoping rate %)															
2nd boom	0	0	0	0	0	0	0	0	0	47	93	0	0	0	47	93
3rd boom	0	0	0	0	0	0	0	47	93	93	93	0	0	47	47	47
4th boom	0	0	0	0	0	47	93	93	93	93	93	0	47	47	47	47
5th boom	0	0	0	47	93	93	93	93	93	93	93	47	47	47	47	47
6th boom	0	47	93	93	93	93	93	93	93	93	93	47	47	47	47	47
Number of part lines	21	5	5	5	5	4	4	4	4	4	3	5	5	5	5	5

Unit: ton

Performance C (Counterweight 23 t, Outrigger extension width 7.0 m)

Performance blocks	Unit: ton																
	17	18	19	20	21	22	23	24	25	26	27	28	29	30	31	32	
Performance numbers	32.8m	36.9m	40.9m	40.9m	45.0m	45.0m	49.0m	56.0m	16.6m	20.7m	20.7m	24.7m	28.8m	24.7m	28.8m	32.8m	
Boom length (m)									92.0	80.0	63.0	63.0		40.0			
Working radius (m)	2.7								92.0	80.0	63.0	63.0		40.0			
	3.0								92.0	80.0	63.0	63.0		40.0			
	3.5								86.5	80.0	63.0	63.0	56.0	40.0			
	4.0								80.2	78.2	63.0	63.0	56.0	40.0			
	4.5	32.0	28.5						74.1	72.8	63.0	63.0	56.0	40.0			
	5.0	32.0	28.5						63.6	63.4	63.0	63.0	50.1	40.0			
	6.0	30.3	28.5	22.2	27.3				55.2	55.1	56.1	55.8	45.0	40.0			
	7.0	27.7	28.5	22.2	27.3	21.5	19.8		48.5	48.3	49.4	49.0	40.8	40.0			
	8.0	25.4	27.2	22.2	27.3	21.5	19.8	17.5	42.4	42.3	43.3	42.9	37.2	40.0			
	9.0	23.5	25.3	21.1	27.3	21.5	19.8	17.5	37.0	36.8	37.9	37.6	34.2	38.5	31.2		
	10.0	21.8	23.5	19.6	27.1	21.5	19.8	17.5	27.6	27.4	28.8	28.4	27.9	30.0	29.5	26.6	
	12.0	19.1	20.7	17.1	23.1	21.5	18.5	17.5	19.2	20.6	21.9	21.5	21.0	23.0	22.6	22.0	
	14.0	16.9	18.4	15.2	20.0	18.9	16.3	17.3		16.0	17.2	16.8	16.4	18.3	17.8	17.3	
	16.0	15.2	16.6	13.6	17.5	16.5	14.5	10.8		12.7	13.9	13.5	13.0	14.8	14.4	13.9	
	18.0	13.8	15.1	12.3	14.7	14.6	13.0	13.9	9.9			10.9	10.5	12.2	11.8	11.3	
	20.0	12.6	13.3	11.2	12.1	12.3	11.7	12.3	9.1			9.0	8.5	10.2	9.8	9.3	
	22.0	11.6	11.2	10.2	10.1	10.3	10.5	10.6	8.3								
	24.0	10.0	9.5	9.4	8.4	8.6	9.4	8.9	7.7								
	26.0	8.7	8.2	8.5	7.1	7.3	8.0	7.6	7.2								
	28.0	7.5	7.1	7.3	5.8	6.1	6.9	6.5	6.7								
	30.0	6.6	6.1	6.4	4.8	5.0	5.9	5.4	6.0								
	32.0		5.2	5.6	3.9	4.1	5.0	4.5	5.0								
	34.0		4.4	4.8	3.1	3.3	4.2	3.7	4.2								
	36.0		4.1	4.4	2.6	2.6	3.5	3.0	3.5								
	38.0		3.5	3.5	1.8	2.0	2.9	2.4	2.9								
	40.0				1.5	1.5	2.3	1.8	2.3								
	42.0						1.9	1.3	1.9								
	44.0							1.4									
The maximum load without a pin	32.0	28.5	22.2	27.3	21.5	19.8	17.5	13.5	44.3	41.2	42.3	40.0	30.5	39.3	37.8	29.5	
(°)	0 ~ 81.5	0 ~ 81.5	1 ~ 81.5	5 ~ 81.5	13 ~ 81.5	4 ~ 81.5	23 ~ 81.5	34 ~ 81.5	0 ~ 81.5	0 ~ 81.5	10 ~ 81.5	0 ~ 81.5	1 ~ 81.5	0 ~ 81.5	10 ~ 81.5	2 ~ 81.5	
Boom stage telescoping condition (telescoping rate %)																	
2nd boom	0	47	47	93	93	93	47	93	100	0	47	0	47	93	0	47	93
3rd boom	47	47	47	93	93	93	93	93	100	47	47	47	47	47	47	47	47
4th boom	47	47	47	47	47	93	93	93	100	0	0	47	47	47	47	47	47
5th boom	47	47	93	47	47	47	93	93	100	0	0	0	0	0	0	47	47
6th boom	93	93	93	47	47	47	47	47	100	0	0	0	0	0	0	0	0
Number of part lines	4	4	4	4	4	4	4	4	3	12	10	8	8	8	7	5	5

Performance D (Counterweight 12 t, Outrigger extension width 8.0 m)
(Counterweight 28 t, Outrigger extension width 5.3 m)

Performance blocks	Unit: ton															
	1								2							
Performance numbers	1	2	3	4	5	6	7	8	9	10	11	12	13	14	15	16
Boom length (m)	12.6m	16.6m	20.7m	24.7m	28.8m	32.8m	36.9m	40.9m	45.0m	49.0m	53.1m	20.7m	24.7m	28.8m	32.8m	36.9m
Working radius (m)	2.7	106.9	40.0	36.2	38.8							40.0	40.0			
	3.0	99.8	40.0	34.6	37.0							40.0	40.0			
	3.5	89.7	40.0	32.3	34.4	30.3						40.0	40.0	40.0		
	4.0	81.2	40.0	30.2	32.1	28.2						40.0	40.0	40.0		
	4.5	73.9	39.1	28.4	30.1	26.4	28.5					40.0	40.0	40.0	38.2	
	5.0	67.6	37.3	26.8	28.3	24.7	26.8	24.2				40.0	40.0	40.0	38.2	33.4
	6.0	57.5	34.1	24.0	25.2	22.0	23.4	20.7				37.8	40.0	40.0	38.2	33.4
	7.0	49.5	31.4	21.8	22.8	19.7	21.7	20.9	20.7	17.9		34.3	37.7	40.0	38.2	33.4
	8.0	42.9	29.2	19.9	20.7	17.9	19.8	18.9	20.5	17.9	16.0	31.3	34.4	38.4	38.2	33.4
	9.0	34.8	27.3	18.3	19.0	16.3	18.1	17.2	18.7	17.9	16.0	28.9	31.5	35.4	38.2	31.8
	10.0	29.0	25.7	17.0	17.5	15.0	16.7	15.8	17.2	17.9	16.0	26.7	29.1	32.8	32.3	29.2
	12.0		23.1	14.8	15.2	12.8	14.4	13.4	14.7	15.8	16.0	23.3	24.7	24.6	24.0	23.5
	14.0		17.9	13.1	13.3	11.2	12.7	11.6	12.8	13.8	14.8	19.0	19.3	19.2	18.6	18.2
	16.0			11.8	11.9	9.9	11.2	10.2	11.3	12.2	13.1	15.2	15.5	15.4	14.9	14.4
	18.0			10.9	10.7	8.8	10.1	9.0	10.0	10.9	11.8	12.5	12.8	12.6	12.1	11.7
	20.0			9.8	9.8	7.9	9.1	8.0	9.0	9.8	10.6	10.6	10.6	10.5	10.0	9.5
	22.0			9.1	7.2	8.3	7.2	8.1	8.9	9.1	8.8		8.9	8.8	8.3	7.9
	24.0				6.6	7.6	6.5	7.4	8.0	7.7	7.4			7.4	6.9	6.4
	26.0				6.1	7.0	5.9	6.7	6.9	6.6	6.3			6.3	5.7	5.2
	28.0					6.4	5.4	6.2	5.9	5.6	5.2				4.7	4.1
	30.0					5.6	5.0	5.4	5.1	4.7	4.3				3.8	3.2
	32.0						4.6	4.6	4.3	3.9	3.5				2.4	2.4
	34.0							4.1	3.9	3.6	3.2	2.8			1.8	
	36.0								3.3	3.0	2.6	2.2				
	38.0								2.9	2.4	2.1	1.7				
	40.0								2.0	2.4	2.1	1.7				
	42.0								1.6	1.6	1.2					
The maximum load without a pin	50.6	40.0	25.7	38.8	25.4	28.5	24.2	20.7	17.9	16.0	15.0	40.0	40.0	40.0	38.2	28.4
(°)	0 ~ 81.5	0 ~ 81.5	0 ~ 81.5	0 ~ 81.5	0 ~ 81.5	0 ~ 81.5	0 ~ 81.5	0 ~ 81.5	2 ~ 81.5	2 ~ 81.5	39 ~ 81.5	0 ~ 81.5	0 ~ 81.5	0 ~ 81.5	0 ~ 81.5	2 ~ 81.5
Boom stage telescoping condition (telescoping rate %)																
2nd boom	0	0	0	0	0	0	0	0	0	47	93	0	0	0	47	93
3rd boom	0	0	0	0	0	0	0	47	93	93	93	0	0	47	47	47
4th boom	0	0	0	0	0	47	93	93	93	93	93	0	47	47	47	47
5th boom	0	0	0	47	93	93	93	93	93	93	93	47	47	47	47	47
6th boom	0	47	93	93	93	93	93	93	93	93	93	47	47	47	47	47
Number of part lines	21	5	5	5	5	4	4	4	4	4	3	5	5	5	5	5

Performance D (Counterweight 12 t, Outrigger extension width 8.0 m)
(Counterweight 28 t, Outrigger extension width 5.3 m)

Performance blocks	Unit: ton															
	17	18	19	20	21	22	23	24	25	26	27	28	29	30	31	32
Performance numbers	32.8m	36.9m	40.9m	40.9m	45.0m	45.0m	49.0m	56.0m	16.6m	20.7m	20.7m	24.7m	28.8m	24.7m	28.8m	32.8m
Boom length (m)																
Working radius (m)																
2.7									92.0	80.0	63.0	63.0		40.0		
3.0									92.0	80.0	63.0	63.0		40.0		
3.5									90.2	80.0	63.0	63.0	56.0	40.0	40.0	
4.0									81.7	80.0	63.0	63.0	56.0	40.0	40.0	
4.5									74.4	74.2	63.0	63.0	56.0	40.0	40.0	40.0
5.0		28.5							68.1	68.0	63.0	63.0	56.0	40.0	40.0	40.0
6.0		28.5	22.2	27.3					57.9	57.8	58.9	58.5	50.1	40.0	40.0	40.0
7.0		27.7	28.5	22.2	27.3	21.5	19.8		50.0	49.8	51.0	50.6	45.0	40.0	40.0	40.0
8.0		27.2	22.2	27.3	21.5	19.8	17.5		43.6	43.3	44.6	44.3	40.8	40.0	40.0	37.3
9.0		25.3	21.1	27.3	21.5	19.8	17.5		35.4	35.2	36.7	36.2	35.7	38.0	37.4	34.0
10.0		21.8	23.5	19.6	27.1	21.5	19.8	17.5	29.5	29.3	30.6	30.2	29.7	31.9	31.4	30.8
12.0		19.1	20.7	17.1	23.1	21.5	18.5	17.5	21.4	21.2	22.5	22.1	21.6	23.6	23.1	22.6
14.0		16.9	18.4	15.2	18.2	18.4	16.3	17.3	11.7	16.3	16.0	17.2	16.8	16.4	18.3	17.8
16.0		15.2	15.6	13.6	14.4	14.6	14.5	15.0	10.8	12.4	13.5	13.2	12.7	14.5	14.1	13.6
18.0		13.3	12.8	12.3	11.7	11.9	12.6	12.2	9.9	9.8	10.8	10.5	10.0	11.8	11.3	10.9
20.0		11.1	10.6	10.9	9.5	9.7	10.5	10.0	9.1				8.4	7.9	9.6	8.8
22.0		9.4	8.9	9.2	7.8	8.0	8.8	8.3	8.3				6.6	6.1	8.0	7.6
24.0		8.0	7.5	7.8	6.4	6.6	7.4	7.0	7.5				4.6	4.6	6.1	5.5
26.0		6.9	6.4	6.7	5.1	5.4	6.2	5.7	6.3				3.4	3.4	4.8	4.3
28.0		5.9	5.4	5.7	4.1	4.3	5.2	4.7	5.3							3.2
30.0		5.1	4.5	4.8	3.2	3.4	4.3	3.8	4.3							2.4
32.0			3.7	4.0	2.4	2.6	3.5	3.0	3.5							
34.0			3.1	3.4	1.7	1.9	2.8	2.3	2.8							
36.0			2.8	1.1	1.3	2.2	1.7	2.2	2.2							
38.0			2.3			1.7	1.2	1.7	1.7							
40.0						1.2		1.2	1.2							
The maximum load without a pin	32.0	28.5	22.2	27.3	21.5	19.8	17.5	13.5	44.3	41.2	42.3	40.0	30.5	39.3	37.8	29.5
(°)	0~81.5	0~81.5	1~81.5	19~81.5	33~81.5	18~81.5	36~81.5	44~81.5	0~81.5	0~81.5	0~81.5	0~81.5	1~81.5	0~81.5	0~81.5	2~81.5
Boom stage telescoping condition (telescoping rate %)																
2nd boom	0	47	47	93	93	47	93	100	0	47	0	47	93	0	47	93
3rd boom	47	47	47	93	93	93	93	100	47	47	47	47	47	47	47	47
4th boom	47	47	47	47	47	93	93	100	0	0	47	47	47	47	47	47
5th boom	47	47	93	47	47	93	93	100	0	0	0	0	0	0	47	47
6th boom	93	93	93	47	47	47	47	100	0	0	0	0	0	0	0	0
Number of part lines	4	4	4	4	4	4	4	3	12	10	8	8	7	5	5	5

Performance E (Counterweight 12 t, Outrigger extension width 7.0 m)

Unit: ton

Performance blocks	1																2				
	1	2	3	4	5	6	7	8	9	10	11	12	13	14	15	16					
Performance numbers	12.6m	16.6m	20.7m	24.7m	28.8m	32.8m	36.9m	40.9m	45.0m	49.0m	53.1m	20.7m	24.7m	28.8m	32.8m	36.9m					
Boom length (m)												40.0	40.0								
Working radius (m)	2.7	110.4	40.0	36.2	38.8							40.0	40.0								
3.0	104.0	40.0	34.6	37.0								40.0	40.0								
3.5	94.0	40.0	32.3	34.4	30.3							40.0	40.0	40.0							
4.0	85.3	40.0	30.2	32.1	28.2							40.0	40.0	40.0							
4.5	77.9	39.1	28.4	30.1	26.4	28.5						40.0	40.0	40.0	38.2						
5.0	71.5	37.3	26.8	28.3	24.7	26.8	24.2					40.0	40.0	40.0	38.2	33.4					
6.0	61.0	34.1	24.0	25.2	22.0	24.0	23.4	20.7				37.8	40.0	40.0	38.2	33.4					
7.0	52.2	31.4	21.8	22.8	19.7	21.7	20.9	20.7	17.9			34.3	37.7	40.0	38.2	33.4					
8.0	44.0	29.2	19.9	20.7	17.9	19.8	18.9	20.5	17.9	16.0		31.3	34.4	38.4	38.2	33.4					
9.0	35.8	27.3	18.3	19.0	16.3	18.1	17.2	18.7	17.9	16.0	15.0	28.9	31.5	35.4	38.2	31.8					
10.0	29.0	25.7	17.0	17.5	15.0	16.7	15.8	17.2	17.9	16.0	14.5	26.7	29.1	32.8	32.8	29.2					
12.0		22.7	14.8	15.2	12.8	14.4	13.4	14.7	15.8	16.0	14.5	23.3	24.3	24.2	23.6	23.0					
14.0		17.0	13.1	13.3	11.2	12.7	11.6	12.8	13.8	14.8	13.3	18.2	18.6	18.4	17.8	17.3					
16.0			11.8	11.9	9.9	11.2	10.2	11.3	12.2	13.1	12.2	14.3	14.7	14.5	14.0	13.5					
18.0			10.9	10.7	8.8	10.1	9.0	10.0	10.9	11.8	11.1	11.5	11.8	11.7	11.2	10.7					
20.0				9.8	7.9	9.1	8.0	9.0	9.8	9.9	9.6		9.7	9.5	9.0	8.6					
22.0					7.2	8.3	7.2	8.1	8.5	8.2	7.9		8.0	7.9	7.4	6.9					
24.0					6.6	7.6	6.5	7.4	7.2	6.9	6.6			6.5	6.0	5.5					
26.0					6.1	6.6	5.9	6.4	6.1	5.8	5.4			5.4	4.8	4.2					
28.0						5.7	5.4	5.4	5.1	4.8	4.4				3.8	3.2					
30.0						4.9	4.8	4.6	4.3	3.9	3.5				3.0	2.4					
32.0							4.0	3.9	3.5	3.1	2.7					1.6					
34.0								3.4	3.2	2.8	2.5										
36.0									2.7	2.3	1.9	1.5									
38.0									2.2	1.8	1.4										
40.0										1.4											
The maximum load without a pin	50.6	40.0	25.7	38.8	25.4	28.5	24.2	20.7	17.9	16.0	15.0	40.0	40.0	40.0	38.2	28.4					
(°)	0~81.5	0~81.5	0~81.5	0~81.5	0~81.5	0~81.5	0~81.5	0~81.5	13~81.5	34~81.5	44~81.5	0~81.5	0~81.5	0~81.5	0~81.5	13~81.5					
Boom stage telescoping condition (telescoping rate %)																					
2nd boom	0	0	0	0	0	0	0	0	0	0	93	0	0	0	47	93					
3rd boom	0	0	0	0	0	0	0	47	93	93	93	0	0	47	47	47					
4th boom	0	0	0	0	0	47	93	93	93	93	93	47	47	47	47	47					
5th boom	0	0	0	47	93	93	93	93	93	93	93	47	47	47	47	47					
6th boom	0	47	93	93	93	93	93	93	93	93	93	47	47	47	47	47					
Number of part lines	21	5	5	5	5	4	4	4	4	4	3	5	5	5	5	5					

Performance E (Counterweight 12 t, Outrigger extension width 7.0 m)

Performance blocks		3	4	5	6	7	8	9	10	11	Unit: ton					
Performance numbers	17	18	19	20	21	22	23	24	25	26	27	28	29	30	31	32
Boom length (m)	32.8m	36.9m	40.9m	40.9m	45.0m	45.0m	49.0m	56.0m	16.6m	20.7m	20.7m	24.7m	28.8m	24.7m	28.8m	32.8m
Working radius (m)	2.7								92.0	80.0	63.0	63.0	63.0	40.0		
3.0									92.0	80.0	63.0	63.0	56.0	40.0		
3.5									92.0	80.0	63.0	63.0	56.0	40.0		
4.0									85.8	80.0	63.0	63.0	56.0	40.0		
4.5	32.0								78.4	78.2	63.0	63.0	56.0	40.0		
5.0	32.0	28.5							72.0	71.8	63.0	63.0	56.0	40.0		
6.0	30.3	28.5	22.2	27.3					61.5	61.3	62.4	62.1	50.1	40.0		
7.0	27.7	28.5	22.2	27.3	21.5	19.8			52.7	52.5	53.6	53.2	45.0	40.0		
8.0	25.4	27.2	22.2	27.3	21.5	19.8	17.5		44.5	44.4	45.5	45.2	40.8	40.0		
9.0	23.5	25.3	21.1	27.3	21.5	19.8	17.5		36.5	36.2	37.9	37.4	36.8	39.4	38.8	34.0
10.0	21.8	23.5	19.6	27.1	21.5	19.8	17.5	13.5	29.6	29.4	30.9	30.4	29.9	32.3	31.8	31.1
12.0	19.1	20.7	17.1	23.0	21.5	18.5	17.5	12.6	20.7	20.5	21.9	21.4	21.0	23.1	22.6	22.0
14.0	16.9	18.4	15.2	17.3	17.6	16.3	17.3	11.7	15.3	15.0	16.3	15.9	15.4	17.4	17.0	16.4
16.0	15.2	14.7	13.6	13.5	13.7	14.5	14.0	10.8			11.3	12.5	12.1	13.6	13.1	12.6
18.0	12.4	11.9	12.2	10.7	10.9	11.7	11.2	9.9			8.7	9.8	9.4	10.8	10.3	9.8
20.0	10.2	9.7	10.0	8.6	8.8	9.5	9.1						7.3	6.8	8.7	8.2
22.0	8.5	8.0	8.3	6.9	7.1	7.9	7.4	7.9					5.6	5.0	7.0	6.6
24.0	7.2	6.7	7.0	5.4	5.7	6.5	6.1	6.6						3.6		5.1
26.0	6.1	5.6	5.9	4.2	4.5	5.4	4.8	5.5								3.9
28.0	5.1	4.6	4.9	3.2	3.4	4.3	3.8	4.4								2.3
30.0	4.3	3.7	4.0	2.3	2.6	3.4	2.9	3.5								1.5
32.0	2.9	3.3	1.6		1.8	2.7	2.2	2.8								
34.0	2.1	2.3	2.6		1.2	2.0	1.5	2.1								
36.0		2.1				1.5		1.5								
38.0			1.6													
The maximum load without a pin	32.0	28.5	22.2	27.3	21.5	19.8	17.5	13.5	44.3	41.2	42.3	40.0	30.5	39.3	37.8	29.5
(°)	0~81.5	0~81.5	1~81.5	31~81.5	38~81.5	30~81.5	42~81.5	48~81.5	0~81.5	0~81.5	0~81.5	0~81.5	1~81.5	0~81.5	0~81.5	10~81.5
Boom stage telescoping condition (telescoping rate %)																
2nd boom	0	47	47	93	93	93	93	100	0	47	0	47	93	0	47	93
3rd boom	47	47	47	93	93	93	93	100	47	47	47	47	47	47	47	47
4th boom	47	47	47	47	93	93	93	100	0	0	47	47	47	47	47	47
5th boom	47	47	93	47	47	93	93	100	0	0	0	0	0	0	47	47
6th boom	93	93	93	47	47	47	47	100	0	0	0	0	0	0	0	0
Number of part lines	4	4	4	4	4	4	4	3	12	10	8	8	7	5	5	5

Performance F (Counterweight 23 t, Outrigger extension width 5.3 m)
(Counterweight 28 t, Outrigger extension width 4.6 m)

Performance blocks	1										2						Unit: ton
	1	2	3	4	5	6	7	8	9	10	11	12	13	14	15	16	
Performance numbers	12.6m	16.6m	20.7m	24.7m	28.8m	32.8m	36.9m	40.9m	45.0m	49.0m	53.1m	20.7m	24.7m	28.8m	32.8m	36.9m	
Boom length (m)	103.0	40.0	36.2	38.8								40.0	40.0				
Working radius (m)	2.7	95.9	40.0	34.6	37.0							40.0	40.0				
	3.0	85.7	40.0	34.4	30.3							40.0	40.0	40.0			
	3.5	77.3	40.0	32.1	28.2							40.0	40.0	40.0			
	4.0	70.1	39.1	28.4	30.1	26.4	28.5					40.0	40.0	40.0	38.2		
	4.5	64.0	37.3	26.8	28.3	24.7	26.8	24.2				40.0	40.0	40.0	38.2	33.4	
	5.0	54.1	34.1	24.0	25.2	22.0	24.0	23.4				37.8	40.0	40.0	38.2	33.4	
	6.0	45.2	31.4	21.8	22.8	19.7	21.7	20.9	20.7	17.9		34.3	37.7	40.0	38.2	33.4	
	7.0	35.8	29.2	19.9	20.7	17.9	19.8	18.9	20.5	17.9	16.0	31.3	34.4	38.4	38.2	33.4	
	8.0	29.2	27.3	18.3	19.0	16.3	18.1	17.2	18.7	17.9	16.0	15.0	28.9	31.5	33.2	31.8	
	9.0	24.3	25.7	17.0	17.5	15.0	16.7	15.8	17.2	17.9	16.0	14.9	26.7	28.2	28.1	27.5	
	10.0		19.8	14.8	15.2	12.8	14.4	13.4	14.7	15.8	16.0	14.5	20.9	21.2	21.0	20.5	
	12.0		13.1	13.3	11.2	12.7	11.6	12.8	13.8	14.8	13.3	16.2	16.5	16.4	15.9	15.4	
	14.0		11.8	11.9	9.9	11.2	10.2	11.3	12.2	13.1	12.2	13.0	13.3	13.1	12.6	12.2	
	16.0		10.6	10.7	8.8	10.1	9.0	10.0	10.9	11.1	10.8	10.5	10.8	10.7	10.2	9.8	
	18.0			9.5	7.9	9.1	8.0	9.0	9.5	9.2	8.9	9.0	8.8	8.8	8.3	7.9	
	20.0			8.0	7.2	8.3	7.2	8.1	7.9	7.7	7.4	7.4	7.5	7.3	6.8	6.4	
	22.0				6.6	7.2	6.5	7.0	6.7	6.4	6.1			6.1	5.5	5.0	
	24.0				6.0	6.2	5.9	6.0	5.7	5.4	5.0			5.0	4.4	3.9	
	26.0				5.3	5.2	5.1	4.8	4.4	4.0					3.5	2.9	
	28.0				4.6	4.4	4.3	3.9	3.6	3.2					2.7	2.1	
	30.0					3.7	3.6	3.2	2.9	2.5						1.4	
	32.0					3.1	3.0	2.6	2.3	1.9							
	34.0						2.5	2.1	1.7	1.3							
	36.0						2.0	1.6	1.3								
	38.0							1.2									
	40.0																
The maximum load without a pin	50.6	40.0	25.7	38.8	25.4	28.5	24.2	20.7	17.9	16.0	15.0	40.0	40.0	40.0	38.2	28.4	
(°)	0 ~ 81.5	0 ~ 81.5	0 ~ 81.5	0 ~ 81.5	0 ~ 81.5	0 ~ 81.5	0 ~ 81.5	0 ~ 81.5	13 ~ 81.5	36 ~ 81.5	46 ~ 81.5	0 ~ 81.5	0 ~ 81.5	0 ~ 81.5	0 ~ 81.5	19 ~ 81.5	
Boom stage telescoping condition (telescoping rate %)																	
2nd boom	0	0	0	0	0	0	0	0	0	47	93	0	0	0	47	93	
3rd boom	0	0	0	0	0	0	0	47	93	93	93	0	0	47	47	47	
4th boom	0	0	0	0	0	47	93	93	93	93	93	0	47	47	47	47	
5th boom	0	0	0	47	93	93	93	93	93	93	93	47	47	47	47	47	
6th boom	0	47	93	93	93	93	93	93	93	93	93	47	47	47	47	47	
Number of part lines	21	5	5	5	5	4	4	4	4	4	3	5	5	5	5	5	

Performance F
 (Counterweight 23 t, Outrigger extension width 5.3 m)
 (Counterweight 28 t, Outrigger extension width 4.6 m)

Performance blocks	Unit: ton															
	3	4	5	6	7	8	9	10	11	11	32					
Performance numbers	17	18	19	20	21	22	23	24	25	26	27	28	29	30	31	32
Boom length (m)	32.8m	36.9m	40.9m	40.9m	45.0m	45.0m	49.0m	56.0m	16.6m	20.7m	20.7m	24.7m	28.8m	24.7m	28.8m	32.8m
Working radius (m)	2.7								92.0	80.0	63.0	63.0		40.0		
3.0									92.0	80.0	63.0	63.0		40.0		
3.5									86.2	80.0	63.0	63.0	56.0	40.0	40.0	
4.0									77.8	77.6	63.0	63.0	56.0	40.0	40.0	
4.5	32.0								70.6	70.5	63.0	63.0	56.0	40.0	40.0	40.0
5.0	32.0	28.5							64.5	64.4	63.0	63.0	56.0	40.0	40.0	40.0
6.0	30.3	28.5	22.2	27.3	21.5				54.6	54.5	55.6	55.2	50.1	40.0	40.0	40.0
7.0	27.7	28.5	22.2	27.3	21.5	19.8			45.9	45.7	47.3	46.8	45.0	40.0	40.0	40.0
8.0	25.4	27.2	22.2	27.3	21.5	19.8	17.5		36.4	36.2	37.7	37.2	36.7	39.0	38.4	37.3
9.0	23.5	25.3	21.1	27.3	21.5	19.8	17.5		29.7	29.5	30.9	30.5	30.0	32.2	31.6	31.1
10.0	21.8	23.5	19.6	27.0	21.5	19.8	17.5	13.5	24.8	24.6	25.9	25.5	25.1	27.1	26.6	26.1
12.0	19.1	20.7	17.1	20.0	20.2	18.5	17.5	12.6	18.0	17.8	19.0	18.6	18.2	20.1	19.7	19.1
14.0	16.9	16.6	15.2	15.4	15.6	16.3	16.0	11.7	13.6	13.3	14.5	14.1	13.7	15.5	15.1	14.6
16.0	13.8	13.3	13.6	12.2	12.4	13.1	12.7	10.8		10.2	11.3	10.9	10.5	12.3	11.9	11.4
18.0	11.3	10.9	11.2	9.8	10.0	10.7	10.3	9.9		7.8	9.0	8.6	8.1	9.9	9.5	9.0
20.0	9.4	9.0	9.3	7.9	8.1	8.8	8.4	8.9				6.6	6.1	8.0	7.6	7.1
22.0	7.9	7.5	7.7	6.3	6.6	7.3	6.9	7.4				5.0	4.5	6.5	6.0	5.4
24.0	6.7	6.2	6.5	5.0	5.2	6.1	5.6	6.2					3.2	4.6	4.1	
26.0	5.7	5.2	5.5	3.8	4.1	4.9	4.4	5.0					2.1	3.5	3.0	
28.0	4.8	4.2	4.5	2.9	3.1	4.0	3.5	4.1							2.0	
30.0	4.0	3.4	3.7	2.1	2.3	3.2	2.7	3.2							1.3	
32.0		2.7	3.0	1.4	1.6	2.5	2.0	2.5								
34.0		2.1	2.4			1.8	1.3	1.9								
36.0			1.9			1.3		1.4								
38.0																
The maximum load without a pin	32.0	28.5	22.2	27.3	21.5	19.8	17.5	13.5	44.3	41.2	42.3	40.0	30.5	39.3	37.8	29.5
(°)	0 ~ 81.5	0 ~ 81.5	11 ~ 81.5	34 ~ 81.5	40 ~ 81.5	30 ~ 81.5	44 ~ 81.5	48 ~ 81.5	10 ~ 81.5	0 ~ 81.5	10 ~ 81.5	10 ~ 81.5	1 ~ 81.5	10 ~ 81.5	10 ~ 81.5	10 ~ 81.5
Boom stage telescoping condition (telescoping rate %)																
2nd boom	0	47	47	93	93	93	93	100	0	47	0	47	93	0	47	93
3rd boom	47	47	47	93	93	93	93	100	47	47	47	47	47	47	47	47
4th boom	47	47	47	93	93	93	93	100	0	0	0	47	47	47	47	47
5th boom	47	47	93	47	47	93	93	100	0	0	0	0	0	0	47	47
6th boom	93	93	93	47	47	47	47	100	0	0	0	0	0	0	0	0
Number of part lines	4	4	4	4	4	4	4	3	12	10	8	8	7	5	5	5

Performance G

(Counterweight 0 t, Outrigger extension width 8.0 m)
 (Counterweight 0 t, Outrigger extension width 7.0 m)
 (Counterweight 12 t, Outrigger extension width 5.3 m)
 (Counterweight 23 t, Outrigger extension width 4.6 m)

Performance blocks	Unit: ton																
	1								2								
Performance numbers	1	2	3	4	5	6	7	8	9	10	11	12	13	14	15	16	
Boom length (m)	12.6m	16.6m	20.7m	24.7m	28.8m	32.8m	36.9m	40.9m	45.0m	49.0m	53.1m	20.7m	24.7m	28.8m	32.8m	36.9m	
Working radius (m)	2.7	101.3	40.0	36.2	38.8							40.0	40.0				
3.0	94.2	40.0	34.6	37.0								40.0	40.0				
3.5	84.1	40.0	32.3	34.4	30.3							40.0	40.0	40.0			
4.0	75.8	40.0	30.2	32.1	28.2							40.0	40.0	40.0			
4.5	68.7	39.1	28.4	30.1	26.4	28.5						40.0	40.0	40.0	38.2		
5.0	62.6	37.3	26.8	28.3	24.7	26.8	24.2					40.0	40.0	40.0	38.2	33.4	
6.0	51.0	34.1	24.0	25.2	22.0	24.0	23.4	20.7				37.8	40.0	40.0	38.2	33.4	
7.0	37.3	31.4	21.8	22.8	19.7	21.7	20.9	20.7	17.9			34.3	37.7	40.0	38.2	33.4	
8.0	28.7	29.2	19.9	20.7	17.9	19.8	18.9	20.5	17.9	16.0		31.3	33.5	33.3	32.6	32.1	
9.0	22.9	25.6	18.3	19.0	16.3	18.1	17.2	18.7	17.9	16.0	15.0	26.9	27.3	27.1	26.5	25.9	
10.0	18.6	21.2	17.0	17.5	15.0	16.7	15.8	17.2	17.9	16.0	14.9	22.4	22.8	22.6	22.0	21.5	
12.0		15.1	14.8	15.2	12.8	14.4	13.4	14.7	15.8	16.0	14.5	16.3	16.6	16.4	15.9	15.4	
14.0		10.8	12.1	13.1	11.2	12.7	11.6	12.8	13.1	12.7	12.4	12.0	12.4	12.2	11.7	11.2	
16.0			9.2	10.1	9.9	10.6	10.2	10.4	10.1	9.8	9.4	9.1	9.5	9.3	8.8	8.3	
18.0			7.1	8.0	8.2	8.5	8.4	8.3	8.0	7.6	7.3	7.0	7.3	7.2	6.7	6.2	
20.0				6.4	6.6	6.8	6.7	6.6	6.3	6.0	5.7	5.7	5.8	5.6	5.1	4.5	
22.0				5.1	5.3	5.6	5.5	5.4	5.1	4.7	4.3	4.3	4.5	4.3	3.7	3.1	
24.0					4.3	4.5	4.4	4.3	4.0	3.6	3.2	3.2	3.2	3.2	2.6	2.0	
26.0					3.4	3.6	3.5	3.4	3.0	2.7	2.3	2.3		2.3	1.6	1.1	
28.0						2.9	2.7	2.6	2.2	1.9							
30.0						2.2	2.1	1.9	1.6	1.2							
32.0							1.5	1.4									
The maximum load without a pin	50.6	40.0	25.7	38.8	25.4	28.5	24.2	20.7	17.9	16.0	15.0	40.0	40.0	40.0	38.2	28.4	
(°)	0 ~ 81.5	0 ~ 81.5	0 ~ 81.5	0 ~ 81.5	0 ~ 81.5	13 ~ 81.5	30 ~ 81.5	43 ~ 81.5	51 ~ 81.5	59 ~ 81.5	60 ~ 81.5	70 ~ 81.5	70 ~ 81.5	70 ~ 81.5	70 ~ 81.5	70 ~ 81.5	
Telescoping rate (%)	Boom stage telescoping condition (telescoping rate %)																
	2nd boom	0	0	0	0	0	0	0	0	0	47	93	0	0	0	47	93
	3rd boom	0	0	0	0	0	0	0	47	93	93	93	0	0	47	47	47
	4th boom	0	0	0	0	0	47	93	93	93	93	93	0	47	47	47	47
	5th boom	0	0	0	47	93	93	93	93	93	93	93	47	47	47	47	47
	6th boom	0	47	93	93	93	93	93	93	93	93	93	47	47	47	47	47
Number of part lines	21	5	5	5	5	4	4	4	4	4	3	5	5	5	5	5	

Performance G

(Counterweight 0 t, Outrigger extension width 8.0 m)
 (Counterweight 0 t, Outrigger extension width 7.0 m)
 (Counterweight 12 t, Outrigger extension width 5.3 m)
 (Counterweight 23 t, Outrigger extension width 4.6 m)

Performance blocks	Unit: ton														
	3	4	5	6	7	8	9	10	11	11	32				
Performance numbers	17	19	20	21	22	23	24	25	26	27	28	29	30	31	32
Boom length (m)	32.8m	40.9m	40.9m	45.0m	45.0m	49.0m	56.0m	16.6m	20.7m	20.7m	24.7m	28.8m	24.7m	28.8m	32.8m
Working radius (m)	2.7							92.0	80.0	63.0	63.0		40.0		
5.0	32.0							92.0	80.0	63.0	63.0		40.0		
6.0	30.3							84.6	80.0	63.0	63.0	56.0	40.0	40.0	
7.0	27.7							76.3	76.1	63.0	63.0	56.0	40.0	40.0	
8.0	25.4							69.2	69.0	63.0	63.0	56.0	40.0	40.0	
9.0	23.5							63.2	63.0	63.0	63.0	56.0	40.0	40.0	
10.0	21.8							51.9	51.6	53.6	53.0	50.1	40.0	40.0	
12.0	17.2							38.1	37.8	39.5	39.0	38.4	40.0	40.0	39.8
14.0	13.0							29.4	29.2	30.7	30.2	29.7	32.1	31.6	30.9
16.0	10.1							23.5	23.2	24.7	24.3	23.8	26.0	25.5	24.9
18.0	7.9							19.2	18.9	20.3	19.9	19.4	21.6	21.1	20.5
20.0	6.3							13.5	13.5	14.3	13.8	13.4	15.5	15.0	14.4
22.0	5.0							12.9	12.9	14.3	13.8	13.4	15.5	15.0	14.4
24.0	3.9							9.1	8.8	10.1	9.7	9.3	11.3	10.8	10.2
26.0	3.0							5.9	5.9	7.3	6.9	6.4	8.4	7.9	7.4
28.0	2.2							3.7	3.7	5.1	4.7	4.2	6.3	5.9	5.2
30.0	1.6										3.0	2.5	4.6	4.1	3.5
The maximum load without a pin	32.0	28.5	27.3	21.5	19.8	17.5	13.5	44.3	41.2	42.3	40.0	30.5	39.3	37.8	29.5
(°)	0 ~ 81.5	31 ~ 81.5	49 ~ 81.5	54 ~ 81.5	49 ~ 81.5	58 ~ 81.5	61 ~ 81.5	0 ~ 81.5	0 ~ 81.5	0 ~ 81.5	0 ~ 81.5	33 ~ 81.5	0 ~ 81.5	20 ~ 81.5	40 ~ 81.5
Boom stage telescoping condition (telescoping rate %)															
2nd boom	0	47	47	93	93	93	100	0	47	0	47	93	0	47	93
3rd boom	47	47	47	93	93	93	100	47	47	47	47	47	47	47	47
4th boom	47	47	47	93	93	93	100	0	0	47	47	47	47	47	47
5th boom	47	47	47	93	93	93	100	0	0	0	0	0	0	47	47
6th boom	93	93	93	47	47	47	100	0	0	0	0	0	0	0	0
Number of part lines	4	4	4	4	4	4	3	12	10	8	8	7	5	5	5

Performance H
 (Counterweight 0 t, Outrigger extension width 5.3 m)
 (Counterweight 0 t, Outrigger extension width 4.6 m)
 (Counterweight 12 t, Outrigger extension width 4.6 m)

Performance blocks	1											2					Unit: ton
	1	2	3	4	5	6	7	8	9	10	11	12	13	14	15	16	
Performance numbers	12.6m	16.6m	20.7m	24.7m	28.8m	32.8m	36.9m	40.9m	45.0m	49.0m	53.1m	20.7m	24.7m	28.8m	32.8m	36.9m	
Boom length (m)	2.7	92.9	40.0	36.2	38.8							40.0	40.0				
Working radius (m)	3.0	86.1	40.0	34.6	37.0							40.0	40.0				
	3.5	76.5	40.0	32.3	34.4	30.3						40.0	40.0	40.0			
	4.0	67.0	40.0	30.2	32.1	28.2						40.0	40.0	40.0			
	4.5	49.8	39.1	28.4	30.1	26.4	28.5					40.0	40.0	40.0	38.2		
	5.0	38.9	37.3	26.8	28.3	24.7	26.8	24.2				40.0	40.0	40.0	38.2	33.4	
	6.0	26.1	29.3	24.0	25.2	22.0	24.0	23.4	20.7			31.0	31.5	31.3	30.6	29.9	
	7.0	18.7	21.7	21.8	22.8	19.7	21.7	20.9	20.7	17.9		23.1	23.5	23.3	22.7	22.1	
	8.0	13.9	16.7	18.1	19.1	17.9	19.8	18.9	19.5	17.9	16.0	17.9	18.3	18.2	17.6	17.0	
	9.0	10.5	13.1	14.4	15.4	15.7	16.0	15.9	15.8	15.5	14.7	14.3	14.7	14.5	14.0	13.4	
	10.0	8.1	10.5	11.8	12.7	13.0	13.3	13.2	13.1	12.7	12.4	11.7	12.0	11.9	11.3	10.8	
	12.0		6.9	8.1	8.9	9.2	9.5	9.4	9.3	9.0	8.6	8.0	8.3	8.1	7.6	7.2	
	14.0		4.3	5.6	6.5	6.7	7.0	6.9	6.8	6.5	6.2	5.5	5.9	5.7	5.2	4.7	
	16.0			3.8	4.7	5.0	5.2	5.1	5.0	4.7	4.4	4.1	3.9	3.3	2.8		
	18.0				2.3	3.3	3.6	3.9	3.8	3.7	3.3	2.9	2.2	2.6	2.5	1.9	
	20.0					2.2	2.5	2.8	2.6	2.5	2.2		1.5	1.3			
	22.0					1.3	1.6	1.9	1.7	1.6							
	24.0																
The maximum load without a pin	50.6	40.0	25.7	38.8	25.4	28.5	24.2	20.7	17.9	16.0	15.0	40.0	40.0	40.0	38.2	28.4	
(°)	0-81.5	0-81.5	0-81.5	6-81.5	31-81.5	37-81.5	47-81.5	55-81.5	60-81.5	66-81.5	71-81.5	7-81.5	21-81.5	40-81.5	53-81.5	60-81.5	
Boom stage telescoping condition (telescoping rate %)																	
2nd boom	0	0	0	0	0	0	0	0	0	47	93	0	0	0	47	93	
3rd boom	0	0	0	0	0	0	0	0	47	93	93	0	0	47	47	47	
4th boom	0	0	0	0	0	47	93	93	93	93	93	47	47	47	47	47	
5th boom	0	0	0	47	93	93	93	93	93	93	93	47	47	47	47	47	
6th boom	0	47	93	93	93	93	93	93	93	93	93	47	47	47	47	47	
Number of part lines	21	5	5	5	5	4	4	4	4	4	3	5	5	5	5	5	

Performance H
 (Counterweight 0 t, Outrigger extension width 5.3 m)
 (Counterweight 0 t, Outrigger extension width 4.6 m)
 (Counterweight 12 t, Outrigger extension width 4.6 m)

Performance blocks		Unit: ton															
		17	3	4	5	6	7	8	9	10	11	32					
Performance numbers		17	18	19	20	21	22	23	24	25	26	27	28	29	30	31	32
Boom length (m)		32.8m	36.9m	40.9m	40.9m	45.0m	49.0m	56.0m	16.6m	20.7m	24.7m	28.8m	24.7m	28.8m	24.7m	28.8m	32.8m
Working radius (m)		2.7								92.0	80.0	63.0	63.0		40.0		
		3.0								86.6	80.0	63.0	63.0		40.0		
		3.5								77.0	76.8	63.0	63.0	56.0	40.0	40.0	
		4.0								68.3	67.9	63.0	63.0	56.0	40.0	40.0	
		4.5								50.9	50.5	52.9	52.2	51.5	40.0	40.0	40.0
		5.0								39.9	39.6	41.7	41.1	40.4	40.0	40.0	40.0
		6.0								26.9	26.6	28.4	27.8	27.3	30.0	29.3	28.6
		7.0								19.4	19.1	20.7	20.2	19.7	22.1	21.6	20.9
		8.0								14.5	14.3	15.8	15.3	14.8	17.1	16.5	15.9
		9.0								11.1	10.9	12.3	11.9	11.4	13.5	13.0	12.4
		10.0								8.6	8.4	9.7	9.3	8.9	10.9	10.4	9.9
		12.0								4.9	4.7	6.1	5.7	5.2	7.2	6.8	6.3
		14.0								5.9	5.3	5.9	5.3	3.1	4.8	4.3	3.7
		16.0								3.9			1.6		2.9	2.4	
		18.0													1.4		
		20.0															
		22.0															
The maximum load without a pin		32.0	28.5	22.2	27.3	21.5	19.8	17.5	13.5	44.3	41.2	42.3	40.0	30.5	39.3	37.8	29.5
(°)		42 ~ 81.5	53 ~ 81.5	58 ~ 81.5	67 ~ 81.5	69 ~ 81.5	66 ~ 81.5	72 ~ 81.5	75 ~ 81.5	10 ~ 81.5	37 ~ 81.5	27 ~ 81.5	49 ~ 81.5	58 ~ 81.5	35 ~ 81.5	51 ~ 81.5	59 ~ 81.5
Boom stage telescoping condition (telescoping rate %)																	
2nd boom		0	47	47	93	93	47	93	100	0	47	0	47	93	0	47	93
3rd boom		47	47	47	93	93	93	93	100	100	47	47	47	47	47	47	47
4th boom		47	47	47	47	93	93	93	100	0	0	47	47	47	47	47	47
5th boom		47	47	93	47	47	93	93	100	0	0	0	0	0	47	47	47
6th boom		93	93	93	47	47	47	47	100	0	0	0	0	0	0	0	0
Number of part lines		4	4	4	4	4	4	4	3	12	10	8	8	7	5	5	5

Performance I (Counterweight 0 t)
(Outrigger extension width 2.68 m)

Performance blocks	Unit: ton					
	1	2	3	4	5	6
Performance numbers						
Boom length (m)	12.6m	16.6m	20.7m	24.7m	28.8m	32.8m
Working radius (m)						
2.7	30.0	30.0	30.0	30.0		
3.0	30.0	30.0	30.0	30.0		
3.5	25.6	28.7	30.0	30.0	30.0	
4.0	19.4	22.2	23.6	24.6	24.9	
4.5	15.2	17.8	19.1	20.0	20.3	20.6
5.0	12.2	14.6	15.8	16.7	16.9	17.2
6.0	8.1	10.3	11.3	12.1	12.4	12.6
7.0	5.4	7.5	8.4	9.2	9.4	9.7
8.0	3.3	5.5	6.4	7.2	7.4	7.6
9.0	1.8	4.0	4.9	5.6	5.8	6.1
10.0		2.8	3.8	4.5	4.7	4.9
12.0			2.0	2.8	3.0	3.2
14.0				1.5	1.7	1.9
The maximum load without a pin	30.0	30.0	25.0	30.0	25.0	25.0
(°)	0 ~ 81.5	34 ~ 81.5	45 ~ 81.5	49 ~ 81.5	56 ~ 81.5	61 ~ 81.5
Boom stage telescoping condition (telescoping rate %)						
2nd boom	0	0	0	0	0	0
3rd boom	0	0	0	0	0	0
4th boom	0	0	0	0	0	47
5th boom	0	0	0	47	93	93
6th boom	0	47	93	93	93	93
Number of part lines	4	4	4	4	4	4

[JIB]

Performance A (Counterweight 28 t, Outrigger extension width 8.0 m)

Unit: ton

Boom length jib length	53.1 m boom + Fully automatic jib												
	9.9 m jib				15.7 m jib				21.5 m jib				
	5 °	2.5 °	4.5 °	6.0 °	5 °	2.5 °	4.5 °	6.0 °	5 °	2.5 °	4.5 °	6.0 °	
Working radius(m)	Total rated loads	Working radius(m)	Total rated loads	Working radius(m)	Total rated loads	Working radius(m)	Total rated loads	Working radius(m)	Total rated loads	Working radius(m)	Total rated loads	Working radius(m)	Total rated loads
81.5	9.4	7.0	12.5	7.0	14.5	6.2	15.3	5.8	17.0	5.7	17.0	5.7	17.0
80	11.3	7.0	14.4	7.0	16.3	6.1	17.0	5.7	18.1	5.6	18.1	5.6	18.1
79	12.6	7.0	15.7	6.9	17.4	6.0	18.1	5.65	19.1	3.35	21.9	2.4	22.0
78	13.9	7.0	16.9	6.75	18.6	5.95	19.2	5.6	20.4	3.25	23.1	2.35	24.2
75	17.7	7.0	20.3	6.35	21.9	5.8	22.4	5.5	24.0	3.05	26.5	2.25	27.4
73	20.2	7.0	22.6	6.1	24.1	5.65	24.4	5.45	26.4	2.9	28.7	2.2	29.4
70	23.5	6.1	25.8	5.65	27.1	5.15	27.3	5.1	29.2	4.65	29.8	2.7	31.9
68	25.6	5.45	27.9	5.15	29.0	4.7	29.2	4.65	32.1	2.6	34.0	2.1	34.3
65	28.7	4.65	30.7	4.45	31.7	4.15	31.8	4.1	32.2	3.25	35.3	2.45	37.0
63	30.7	4.2	32.6	4.05	33.5	3.8	33.5	3.8	34.4	3.05	37.5	2.4	38.9
60	33.6	3.65	35.3	3.5	36.1	3.35	36.1	3.35	37.7	2.8	40.5	2.3	41.6
58	35.4	3.3	37.1	3.2	37.7	3.1	37.7	3.1	39.7	2.65	42.4	2.2	43.4
55	38.0	2.9	39.6	2.8	40.0	2.7	40.0	2.7	42.6	2.4	45.1	2.15	45.8
53	39.7	2.5	41.1	2.35	41.4	2.25	41.4	2.25	44.4	2.2	46.8	2.0	47.3
50	41.9	1.8	43.2	1.7	43.5	1.6	43.5	1.6	46.8	1.6	48.9	1.4	49.3
48	43.4	1.4	44.6	1.3	44.7	1.25	44.7	1.25	48.3	1.25	50.3	1.1	50.6
(°)	47 ~ 81.5	47 ~ 81.5	47 ~ 81.5	62 ~ 81.5	47 ~ 81.5	47 ~ 81.5	47 ~ 81.5	62 ~ 81.5	47 ~ 81.5	47 ~ 81.5	47 ~ 81.5	62 ~ 81.5	47 ~ 81.5

Unit: ton

Boom length jib length	56.0 m boom + Fully automatic jib												
	9.9 m jib				15.7 m jib				21.5 m jib				
	5 °	2.5 °	4.5 °	6.0 °	5 °	2.5 °	4.5 °	6.0 °	5 °	2.5 °	4.5 °	6.0 °	
Working radius(m)	Total rated loads	Working radius(m)	Total rated loads	Working radius(m)	Total rated loads	Working radius(m)	Total rated loads	Working radius(m)	Total rated loads	Working radius(m)	Total rated loads	Working radius(m)	Total rated loads
81.5	10.0	6.2	13.2	6.2	15.4	6.2	16.2	5.75	17.9	4.0	16.8	3.6	19.8
80	12.1	6.2	15.2	6.2	17.3	6.05	17.9	5.65	19.7	3.4	18.8	3.4	21.6
79	13.5	6.2	16.5	6.2	18.5	6.0	19.2	5.65	21.4	4.0	20.1	3.3	22.9
78	14.9	6.2	17.9	6.2	19.7	5.9	20.3	5.6	23.1	4.0	21.5	3.2	24.1
75	18.9	6.2	21.7	6.15	23.3	5.75	23.7	5.45	26.2	4.0	25.3	3.0	27.7
73	21.5	6.2	23.9	5.5	25.5	5.4	25.8	5.25	29.1	4.0	27.8	2.85	30.0
70	25.0	5.4	27.1	4.7	28.5	4.65	28.8	4.6	32.0	3.75	31.5	2.7	33.4
68	27.2	4.8	29.2	4.2	30.5	4.2	30.7	4.2	33.5	3.55	33.8	2.55	35.6
65	30.4	4.1	32.3	3.6	33.4	3.65	33.5	3.65	34.1	3.15	37.3	2.45	38.8
63	32.5	3.65	34.3	3.3	35.3	3.35	35.3	3.35	36.5	3.0	39.5	2.35	40.8
60	35.5	3.15	37.2	2.85	38.0	2.9	38.0	2.9	39.8	2.6	42.6	2.25	43.7
58	37.4	2.8	39.0	2.55	39.7	2.65	39.7	2.65	41.8	2.3	44.6	2.15	45.5
55	40.1	2.3	41.6	2.15	42.1	2.05	42.1	2.05	44.7	1.95	47.2	1.75	48.0
53	41.8	1.85	43.1	1.7	43.5	1.6	43.5	1.6	46.4	1.55	48.8	1.35	49.4
50	44.1	1.2	45.4	1.1	45.6	1.0	45.6	1.0	48.9	1.0	51.0	0.85	51.0
48	45.6	0.8	46.1	0.8	46.1	0.8	46.1	0.8	49.1	0.8	51.0	0.8	51.0
(°)	47 ~ 81.5	49 ~ 81.5	49 ~ 81.5	62 ~ 81.5	49 ~ 81.5	49 ~ 81.5	49 ~ 81.5	62 ~ 81.5	49 ~ 81.5	49 ~ 81.5	49 ~ 81.5	62 ~ 81.5	49 ~ 81.5

Performance B (Counterweight 23 t, Outrigger extension width 8.0 m)
(Counterweight 28 t, Outrigger extension width 7.0 m)

Boom length		53.1 m boom + Fully automatic jib										Unit: ton												
Jib length		9.9 m jib					15.7 m jib					21.5 m jib					60°							
Boom angle ^(°)	Working radius(m)	2.5°		4.5°		5°		2.5°		4.5°		6.0°		5°		2.5°		4.5°		6.0°				
		Working loads	Total rated loads	Working loads	Total rated loads	Working radius(m)	Total rated loads	Working radius(m)	Total rated loads	Working radius(m)	Total rated loads	Working radius(m)	Total rated loads	Working radius(m)	Total rated loads	Working radius(m)	Total rated loads	Working radius(m)	Total rated loads	Working radius(m)	Total rated loads			
81.5	9.4	7.0	12.5	7.0	14.5	6.2	15.3	5.8	11.0	4.4	16.0	3.65	19.0	2.5	20.3	2.15	12.7	2.8	19.5	2.0	23.9	1.3	25.8	1.05
80	11.3	7.0	14.4	7.0	16.3	6.1	17.0	5.7	13.1	4.4	17.8	3.45	20.7	2.4	22.0	2.1	15.0	2.8	21.5	1.85	25.7	1.25	27.5	1.05
79	12.6	7.0	15.7	6.9	17.4	6.0	18.1	5.65	14.5	4.4	19.1	3.35	21.9	2.35	23.1	2.1	16.6	2.8	22.8	1.8	26.9	1.2	28.6	1.05
78	13.9	7.0	16.9	6.75	18.6	5.95	19.2	5.6	16.0	4.4	20.4	3.25	23.1	2.35	24.2	2.05	18.1	2.8	24.2	1.75	28.2	1.2	29.7	1.0
75	17.7	7.0	20.3	6.35	21.9	5.8	22.4	5.5	20.1	4.4	24.0	3.05	26.5	2.25	27.4	2.05	22.5	2.8	28.0	1.6	31.6	1.15	32.9	1.0
73	20.2	7.0	22.6	6.1	24.1	5.65	24.4	5.45	22.7	4.4	26.4	2.9	28.7	2.2	29.4	2.0	25.4	2.75	30.6	1.55	33.9	1.1	35.0	1.0
70	23.5	6.1	25.8	5.65	27.1	5.15	27.3	5.1	26.4	3.85	29.8	2.7	31.9	2.1	32.4	2.0	29.4	2.45	34.2	1.4	37.2	1.05	38.0	0.95
68	25.6	5.45	27.9	5.15	29.0	4.7	29.2	4.65	28.7	3.55	32.1	2.6	34.0	2.1	34.3	1.95	31.9	2.25	36.5	1.35	39.3	1.05	39.9	0.95
65	30.7	4.65	30.7	4.45	31.7	4.15	31.8	4.1	32.2	3.25	35.3	2.45	37.0	2.05	37.1	1.95	35.6	2.0	40.0	1.3	42.4	1.0	42.7	0.95
63	30.7	4.2	32.6	4.05	33.5	3.8	33.5	3.8	34.4	3.05	37.5	2.4	38.9	2.0	38.9	1.95	38.0	1.9	42.2	1.25	44.3	1.0	44.4	0.95
60	33.6	3.65	35.3	3.5	36.1	3.35			37.7	2.8	40.5	2.3	41.6	1.95			41.6	1.75	45.4	1.15	47.1	0.95		
58	35.3	3.15	36.9	2.9	37.6	2.75			39.7	2.65	42.4	2.2	43.4	1.95			43.8	1.65	47.4	1.15	48.9	0.95		
55	37.7	2.25	39.2	2.05	39.8	1.95			42.3	2.0	44.9	1.75	45.7	1.6			46.9	1.5	50.2	1.1	51.4	0.95		
53	39.3	1.75	40.7	1.6	41.2	1.5			44.0	1.55	46.4	1.35	47.0	1.2			48.7	1.25	52.0	1.05	52.9	0.9		
50	41.6	1.1	42.9	1.0	43.2	0.9			46.3	0.95	48.5	0.8												
(°)	49~81.5		49~81.5		49~81.5		62~81.5		49~81.5		49~81.5		52~81.5		62~81.5		52~81.5		52~81.5		52~81.5		62~81.5	

Boom length		56.0 m boom + Fully automatic jib										Unit: ton												
Jib length		9.9 m jib					15.7 m jib					21.5 m jib					60°							
Boom angle ^(°)	Working radius(m)	2.5°		4.5°		5°		2.5°		4.5°		6.0°		5°		2.5°		4.5°		6.0°				
		Working loads	Total rated loads	Working loads	Total rated loads	Working radius(m)	Total rated loads	Working radius(m)	Total rated loads	Working radius(m)	Total rated loads	Working radius(m)	Total rated loads	Working radius(m)	Total rated loads	Working radius(m)	Total rated loads	Working radius(m)	Total rated loads	Working radius(m)	Total rated loads			
81.5	10.0	6.2	13.2	6.2	15.4	6.2	16.2	5.75	11.7	4.0	16.8	3.6	19.8	2.45	21.1	2.15	13.3	2.5	20.3	1.95	24.6	1.25	26.5	1.05
80	12.1	6.2	15.2	6.2	17.3	6.05	17.9	5.65	13.9	4.0	18.8	3.4	21.6	2.4	22.9	2.1	15.8	2.5	22.4	1.85	26.6	1.2	28.3	1.05
79	13.5	6.2	16.5	6.2	18.5	6.0	19.2	5.65	15.4	4.0	20.1	3.3	22.9	2.35	24.0	2.05	17.4	2.5	23.9	1.8	27.9	1.2	29.5	1.0
78	14.9	6.2	17.9	6.2	19.7	5.9	20.3	5.6	16.9	4.0	21.5	3.2	24.1	2.3	25.2	2.05	19.0	2.5	25.2	1.7	29.1	1.15	30.7	1.0
75	18.9	6.2	21.7	6.15	23.3	5.75	23.7	5.45	21.2	4.0	25.3	3.0	27.7	2.2	28.5	2.0	23.6	2.5	29.3	1.6	32.8	1.1	34.1	1.0
73	21.5	6.2	23.9	5.5	25.5	5.4	25.8	5.25	24.1	4.0	27.8	2.85	30.0	2.15	30.7	2.0	26.7	2.5	31.9	1.5	35.2	1.1	36.2	0.95
70	25.0	5.4	27.1	4.7	28.5	4.65	28.8	4.6	28.0	3.75	31.5	2.7	33.4	2.1	33.9	1.95	30.9	2.3	35.8	1.4	38.7	1.05	39.4	0.95
68	27.2	4.8	29.2	4.2	30.5	4.2	30.7	4.2	30.5	3.5	33.8	2.55	35.6	2.05	35.9	1.95	33.6	2.15	38.3	1.35	40.9	1.0	41.4	0.95
65	30.4	4.1	32.3	3.6	33.4	3.65	33.5	3.65	34.1	3.15	37.3	2.45	38.8	2.0	38.9	1.95	37.5	1.9	41.8	1.25	44.1	1.0	44.4	0.95
63	32.5	3.65	34.3	3.3	35.3	3.35	35.3	3.35	36.5	3.0	39.5	2.35	40.8	2.0	40.8	1.95	40.0	1.8	44.2	1.2	46.2	0.95	46.2	0.95
60	35.5	3.05	37.2	2.8	37.9	2.65			39.8	2.6	42.6	2.25	43.7	1.95			43.7	1.65	47.5	1.15	49.1	0.95		
58	37.2	2.4	38.8	2.2	39.5	2.1			41.6	2.05	44.3	1.8	45.3	1.6			46.0	1.55	49.6	1.1	51.0	0.95		
55	39.7	1.6	41.2	1.45	41.7	1.35			44.2	1.3	46.7	1.15	47.6	1.0			48.9	1.1	52.3	0.85				
53	41.3	1.1	42.8	1.0	43.2	0.95			45.9	0.9														
(°)	52~81.5		52~81.5		52~81.5		62~81.5		52~81.5		54~81.5		54~81.5		62~81.5		54~81.5		54~81.5		57~81.5		62~81.5	

Performance C (Counterweight 23 t, Outrigger extension width 7.0 m)

Boom length jib length		53.1 m boom + Fully automatic jib												Unit: ton											
		9.9 m jib				15.7 m jib				21.5 m jib															
Offset	Working radius (m)	Total rated load (t)	Working load (t)	5 °	6 0 °	5 °	6 0 °	4 5 °	6 0 °	5 °	6 0 °	4 5 °	6 0 °												
81.5	9.4	7.0	12.5	7.0	14.5	6.2	15.3	5.8	11.0	4.4	16.0	3.65	19.0	2.5	20.3	2.15	12.7	2.8	19.5	2.0	23.9	1.3	25.8	1.05	
80	11.3	7.0	14.4	7.0	16.3	6.1	17.0	5.7	13.1	4.4	17.8	3.45	20.7	2.4	22.0	2.1	15.0	2.8	21.5	1.85	25.7	1.25	27.5	1.05	
79	12.6	7.0	15.7	6.9	17.4	6.0	18.1	5.65	14.5	4.4	19.1	3.35	21.9	2.35	23.1	2.1	16.6	2.8	22.8	1.8	26.9	1.2	28.6	1.05	
78	13.9	7.0	16.9	6.75	18.6	5.95	19.2	5.6	16.0	4.4	20.4	3.25	23.1	2.35	24.2	2.05	18.1	2.8	24.2	1.75	28.2	1.2	29.7	1.0	
75	17.7	7.0	20.3	6.35	21.9	5.8	22.4	5.5	20.1	4.4	24.0	3.05	26.5	2.25	27.4	2.05	22.5	2.8	28.0	1.6	31.6	1.15	32.9	1.0	
73	20.2	7.0	22.6	6.1	24.1	5.65	24.4	5.45	22.7	4.3	26.4	2.9	28.7	2.2	29.4	2.0	25.4	2.75	30.6	1.55	33.9	1.1	35.0	1.0	
70	23.5	6.1	25.8	5.65	27.1	5.15	27.3	5.1	26.4	3.85	29.8	2.7	31.9	2.1	32.4	2.0	29.4	2.45	34.2	1.4	37.2	1.05	38.0	0.95	
68	25.6	5.45	27.9	5.15	29.0	4.7	29.2	4.65	28.7	3.55	32.1	2.6	34.0	2.1	34.3	1.95	31.9	2.25	36.5	1.35	39.3	1.05	39.9	0.95	
65	28.7	4.65	30.7	4.45	31.7	4.15	31.8	4.1	32.2	3.25	35.3	2.45	37.0	2.05	37.1	1.95	35.6	2.0	40.0	1.3	42.4	1.0	42.7	0.95	
63	30.7	4.2	32.6	3.95	33.5	3.7	33.4	3.6	34.4	3.05	37.5	2.3	38.9	2.0	38.9	1.95	38.0	1.9	42.2	1.25	44.3	1.0	44.4	0.95	
60	33.3	3.15	35.1	2.85	35.8	2.7	35.8	2.7	37.7	2.8	40.5	2.3	41.6	1.95	41.6	1.75	45.4	1.15	47.1	0.95	48.9	0.95			
58	35.0	2.45	36.7	2.25	37.3	2.1	37.3	2.1	39.4	2.2	42.2	1.9	43.2	1.7	43.8	1.65	47.4	1.15	48.9	0.95					
55	37.4	1.6	39.0	1.45	39.5	1.35	39.5	1.35	41.9	1.4	44.5	1.2	45.4	1.1	46.5	1.15	50.0	0.9	51.3	0.8					
53	39.0	1.1	40.5	1.0	41.0	0.95	41.0	0.95	43.5	0.95	46.0	0.8													
(°)	52 ~ 81.5		52 ~ 81.5		52 ~ 81.5		62 ~ 81.5		52 ~ 81.5		52 ~ 81.5		54 ~ 81.5		62 ~ 81.5		54 ~ 81.5		54 ~ 81.5		54 ~ 81.5		54 ~ 81.5		62 ~ 81.5

Boom length jib length		56.0 m boom + Fully automatic jib												Unit: ton											
		9.9 m jib				15.7 m jib				21.5 m jib															
Offset	Working radius (m)	Total rated load (t)	Working load (t)	5 °	6 0 °	5 °	6 0 °	4 5 °	6 0 °	5 °	6 0 °	4 5 °	6 0 °												
81.5	10.0	6.2	13.2	6.2	15.4	6.2	16.2	5.75	11.7	4.0	16.8	3.6	19.8	2.45	21.1	2.15	13.3	2.5	20.3	1.95	24.6	1.25	26.5	1.05	
80	12.1	6.2	15.2	6.2	17.3	6.05	17.9	5.65	13.9	4.0	18.8	3.4	21.6	2.4	22.9	2.1	15.8	2.5	22.4	1.85	26.6	1.2	28.3	1.05	
79	13.5	6.2	16.5	6.2	18.5	6.0	19.2	5.6	15.4	4.0	20.1	3.3	22.9	2.35	24.0	2.05	17.4	2.5	23.9	1.8	27.9	1.2	29.5	1.0	
78	14.9	6.2	17.9	6.2	19.7	5.9	20.3	5.6	16.9	4.0	21.5	3.2	24.1	2.3	25.2	2.05	19.0	2.5	25.2	1.7	29.1	1.15	30.7	1.0	
75	18.9	6.2	21.7	6.15	23.3	5.75	23.7	5.45	21.2	4.0	25.3	3.0	27.7	2.2	28.5	2.0	23.6	2.5	29.3	1.6	32.8	1.1	34.1	1.0	
73	21.5	6.2	23.9	5.5	25.5	5.4	25.8	5.25	24.1	4.0	27.8	2.85	30.0	2.15	30.7	2.0	26.7	2.5	31.9	1.5	35.2	1.1	36.2	0.95	
70	25.0	5.4	27.1	4.7	28.5	4.65	28.8	4.6	28.0	3.75	31.5	2.7	33.4	2.1	33.9	1.95	30.9	2.3	35.8	1.4	38.7	1.05	39.4	0.95	
68	27.2	4.8	29.2	4.2	30.5	4.2	30.7	4.2	30.5	3.5	33.8	2.55	35.6	2.05	35.9	1.95	33.6	2.15	38.3	1.35	40.9	1.0	41.4	0.95	
65	30.4	4.1	32.3	3.6	33.4	3.65	33.5	3.65	34.1	3.15	37.3	2.45	38.8	2.0	38.9	1.95	37.5	1.9	41.8	1.25	44.1	1.0	44.4	0.95	
63	32.4	3.5	34.3	3.2	35.1	3.0	35.1	2.9	36.5	3.0	39.5	2.35	40.8	2.0	40.8	1.95	40.0	1.8	44.2	1.2	46.2	0.95	46.2	0.95	
60	35.1	2.4	36.8	2.15	37.6	2.0	37.6	2.0	39.3	2.0	42.2	1.75	43.5	1.55	43.7	1.65	43.7	1.65	47.5	1.15	49.1	0.95			
58	36.8	1.75	38.5	1.6	39.2	1.5	39.2	1.5	41.1	1.45	43.9	1.25	45.0	1.1	45.5	1.2	45.5	1.2	49.4	0.95					
55	39.4	0.95																							
(°)	54 ~ 81.5		57 ~ 81.5		57 ~ 81.5		62 ~ 81.5		57 ~ 81.5		57 ~ 81.5		57 ~ 81.5		62 ~ 81.5		57 ~ 81.5		57 ~ 81.5		57 ~ 81.5		59 ~ 81.5		62 ~ 81.5

Performance E (Counterweight 12 t, Outrigger extension width 7.0 m)

Unit: ton

Boom length Jib length	53.1 m boom + Fully automatic jib																							
	9.9 m jib				15.7 m jib				21.5 m jib															
	5 °	2.5 °	4.5 °	6.0 °	5 °	2.5 °	4.5 °	6.0 °	5 °	2.5 °	4.5 °	6.0 °												
Working radius(m)	Total rated loads	Working radius(m)	Total rated loads	Working radius(m)	Total rated loads	Working radius(m)	Total rated loads	Working radius(m)	Total rated loads	Working radius(m)	Total rated loads	Working radius(m)	Total rated loads											
Offset																								
81.5	9.4	7.0	12.5	7.0	14.5	6.2	15.3	5.8	11.0	4.4	16.0	3.65	19.0	2.5	20.3	2.15	12.7	2.8	19.5	2.0	23.9	1.3	25.8	1.05
80	11.3	7.0	14.4	7.0	16.3	6.1	17.0	5.7	13.1	4.4	17.8	3.45	20.7	2.4	22.0	2.1	15.0	2.8	21.5	1.85	25.7	1.25	27.5	1.05
79	12.6	7.0	15.7	6.9	17.4	6.0	18.1	5.65	14.5	4.4	19.1	3.35	21.9	2.35	23.1	2.1	16.6	2.8	22.8	1.8	26.9	1.2	28.6	1.05
78	13.9	7.0	16.9	6.75	18.6	5.95	19.2	5.6	16.0	4.4	20.4	3.25	23.1	2.35	24.2	2.05	18.1	2.8	24.2	1.75	28.2	1.2	29.7	1.0
75	17.7	7.0	20.3	6.35	21.9	5.8	22.4	5.5	20.1	4.0	24.0	3.05	26.5	2.25	27.4	2.05	22.5	2.8	28.0	1.6	31.6	1.15	32.9	1.0
73	20.2	7.0	22.6	6.1	24.1	5.65	24.4	5.45	22.7	4.3	26.4	2.9	28.7	2.2	29.4	2.0	25.4	2.75	30.6	1.55	33.9	1.1	35.0	1.0
70	23.3	5.55	25.5	4.85	26.8	4.45	27.1	4.25	26.4	3.85	29.8	2.7	31.9	2.1	32.4	2.0	29.4	2.45	34.2	1.4	37.2	1.05	38.0	0.95
68	25.2	4.3	27.3	3.75	28.5	3.45	28.7	3.3	28.7	3.55	32.1	2.6	34.0	2.1	34.3	1.95	31.9	2.25	36.5	1.35	39.3	1.05	39.9	0.95
65	27.9	2.75	29.9	2.45	31.0	2.25	31.1	2.15	31.7	2.45	35.1	2.05	36.8	1.75	37.0	1.65	35.6	2.0	40.0	1.3	42.4	1.0		
63	29.7	1.95	31.6	1.7	32.6	1.55	32.7	1.5	33.6	1.75														
(°)	62~81.5	62~81.5	62~81.5	62~81.5	62~81.5	62~81.5	62~81.5	62~81.5	62~81.5	62~81.5	64~81.5	64~81.5	64~81.5	64~81.5	64~81.5	64~81.5	64~81.5	64~81.5	64~81.5	64~81.5	64~81.5	64~81.5	64~81.5	67~81.5

Unit: ton

Boom length Jib length	56.0 m boom + Fully automatic jib																							
	9.9 m jib				15.7 m jib				21.5 m jib															
	5 °	2.5 °	4.5 °	6.0 °	5 °	2.5 °	4.5 °	6.0 °	5 °	2.5 °	4.5 °	6.0 °												
Working radius(m)	Total rated loads	Working radius(m)	Total rated loads	Working radius(m)	Total rated loads	Working radius(m)	Total rated loads	Working radius(m)	Total rated loads	Working radius(m)	Total rated loads	Working radius(m)	Total rated loads											
Offset																								
81.5	10.0	6.2	13.2	6.2	15.4	6.2	16.2	5.75	11.7	4.0	16.8	3.6	19.8	2.45	21.1	2.15	13.3	2.5	20.3	1.95	24.6	1.25	26.5	1.05
80	12.1	6.2	15.2	6.2	17.3	6.05	17.9	5.65	13.9	4.0	18.8	3.4	21.6	2.4	22.9	2.1	15.8	2.5	22.4	1.85	26.6	1.2	28.3	1.05
79	13.5	6.2	16.5	6.2	18.5	6.0	19.2	5.65	15.4	4.0	20.1	3.3	22.9	2.35	24.0	2.05	17.4	2.5	23.9	1.8	27.9	1.2	29.5	1.0
78	14.9	6.2	17.9	6.2	19.7	5.9	20.3	5.6	16.9	4.0	21.5	3.2	24.1	2.3	25.2	2.05	19.0	2.5	25.2	1.7	29.1	1.15	30.7	1.0
75	18.9	6.2	21.7	6.15	23.3	5.75	23.7	5.45	21.2	4.0	25.3	3.0	27.7	2.2	28.5	2.0	23.6	2.5	29.3	1.6	32.8	1.1	34.1	1.0
73	21.5	6.2	23.9	5.5	25.5	5.35	25.8	5.1	24.1	4.0	27.8	2.85	30.0	2.15	30.7	2.0	26.7	2.5	31.9	1.5	35.2	1.1	36.2	0.95
70	24.6	4.55	26.8	4.0	28.1	3.65	28.4	3.5	28.0	3.75	31.5	2.7	33.4	2.1	33.9	1.95	30.9	2.3	35.8	1.4	38.7	1.05	39.4	0.95
68	26.6	3.4	28.6	2.95	29.8	2.7	30.1	2.6	30.1	2.85	33.7	2.35	35.6	2.05	35.9	1.9	33.6	2.15	38.3	1.35	40.9	1.0		
65	29.4	2.0																						
(°)	64~81.5	67~81.5	67~81.5	67~81.5	67~81.5	67~81.5	67~81.5	67~81.5	67~81.5	67~81.5	67~81.5	67~81.5	67~81.5	67~81.5	67~81.5	67~81.5	67~81.5	67~81.5	67~81.5	67~81.5	67~81.5	67~81.5	67~81.5	69~81.5

Performance F (Counterweight 23 t, Outrigger extension width 5.3 m)

Ur

Boom length		9.9 m jib						15.7 m jib						21.5 m jib									
Jib length		2.5 °		4.5 °		6.0 °		5 °		2.5 °		4.5 °		6.0 °		5 °		2.5 °		4.5 °		6.0 °	
Offset	Working angle *	Total rated load (t)	Working load (t)	Total rated load (t)	Working load (t)	Total rated load (t)	Working load (t)	Total rated load (t)	Working load (t)	Total rated load (t)	Working load (t)	Total rated load (t)	Working load (t)	Total rated load (t)	Working load (t)	Total rated load (t)	Working load (t)	Total rated load (t)	Working load (t)	Total rated load (t)	Working load (t)	Total rated load (t)	Working load (t)
81.5	9.4	7.0	14.4	7.0	14.5	6.2	15.3	5.8	11.0	4.4	16.0	3.65	19.0	2.5	20.3	2.15	12.7	2.8	19.5	2.0	23.9	1.3	25.8
80	11.3	7.0	14.4	7.0	16.3	6.1	17.0	5.7	13.1	4.4	17.8	3.45	20.7	2.4	22.0	2.1	15.0	2.8	21.5	1.85	25.7	1.25	27.5
79	12.6	7.0	15.7	6.9	17.4	6.0	18.1	5.65	14.5	4.4	19.1	3.35	21.9	2.35	23.1	2.1	16.6	2.8	22.8	1.8	26.9	1.2	28.6
78	13.9	7.0	16.9	6.75	18.6	5.95	19.2	5.6	16.0	4.4	20.4	3.25	23.1	2.35	24.2	2.05	18.1	2.8	24.2	1.75	28.2	1.2	29.7
75	17.7	7.0	20.3	6.35	21.9	5.8	22.4	5.5	20.1	4.4	24.0	3.05	26.5	2.25	27.4	2.05	22.5	2.8	28.0	1.6	31.6	1.15	32.9
73	20.2	7.0	22.6	6.1	24.1	5.65	24.4	5.45	22.7	4.3	26.4	2.9	28.7	2.2	29.4	2.0	25.4	2.75	30.6	1.55	33.9	1.1	35.0
70	23.2	5.25	25.4	4.6	26.7	4.2	27.0	4.05	26.4	3.85	29.8	2.7	31.9	2.1	32.4	2.0	29.4	2.45	34.2	1.4	37.2	1.05	38.0
68	25.1	4.05	27.2	3.55	28.4	3.25	28.6	3.15	28.7	3.55	32.1	2.6	34.0	2.1	34.3	1.95	31.9	2.25	36.5	1.35	39.3	1.05	39.9
65	27.8	2.6	29.8	2.3	30.9	2.1	31.1	2.0	31.6	2.3	35.0	1.9	36.7	1.65	36.9	1.55	35.5	1.95	40.0	1.3			
63	29.7	1.8	31.6	1.6					33.5	1.6													
(°)	62 ~ 81.5	62 ~ 81.5		64 ~ 81.5		64 ~ 81.5		62 ~ 81.5		64 ~ 81.5		64 ~ 81.5		64 ~ 81.5		64 ~ 81.5		64 ~ 81.5		64 ~ 81.5		67 ~ 81.5	

Ur

Boom length		9.9 m jib						15.7 m jib						21.5 m jib									
Jib length		2.5 °		4.5 °		6.0 °		5 °		2.5 °		4.5 °		6.0 °		5 °		2.5 °		4.5 °		6.0 °	
Offset	Working angle *	Total rated load (t)	Working load (t)	Total rated load (t)	Working load (t)	Total rated load (t)	Working load (t)	Total rated load (t)	Working load (t)	Total rated load (t)	Working load (t)	Total rated load (t)	Working load (t)	Total rated load (t)	Working load (t)	Total rated load (t)	Working load (t)	Total rated load (t)	Working load (t)	Total rated load (t)	Working load (t)	Total rated load (t)	Working load (t)
81.5	10.0	6.2	13.2	6.2	15.4	6.2	16.2	5.75	11.7	4.0	16.8	3.6	19.8	2.45	21.1	2.15	13.3	2.5	20.3	1.95	24.6	1.25	26.5
80	12.1	6.2	15.2	6.2	17.3	6.05	17.9	5.65	13.9	4.0	18.8	3.4	21.6	2.4	22.9	2.1	15.8	2.5	22.4	1.85	26.6	1.2	28.3
79	13.5	6.2	16.5	6.2	18.5	6.0	19.2	5.65	15.4	4.0	20.1	3.3	22.9	2.35	24.0	2.05	17.4	2.5	23.9	1.8	27.9	1.2	29.5
78	14.9	6.2	17.9	6.2	19.7	5.9	20.3	5.6	16.9	4.0	21.5	3.2	24.1	2.3	25.2	2.05	19.0	2.5	25.2	1.7	29.1	1.15	30.7
75	18.9	6.2	21.7	6.15	23.3	5.75	23.7	5.45	21.2	4.0	25.3	3.0	27.7	2.2	28.5	2.0	23.6	2.5	29.3	1.6	32.8	1.1	34.1
73	21.5	6.2	23.9	5.5	25.3	5.05	25.7	4.85	24.1	4.0	27.8	2.85	30.0	2.15	30.7	2.0	26.7	2.5	31.9	1.5	35.2	1.1	36.2
70	24.5	4.3	26.7	3.75	28.0	3.45	28.3	3.3	28.0	3.7	33.4	2.1	33.9	1.95	33.9	1.95	30.9	2.3	35.8	1.4	38.7	1.05	39.4
68	26.5	3.2	28.6	2.8	29.8	2.55	30.0	2.45	30.0	2.7	33.5	2.2	35.5	1.9	35.9	1.8	33.6	2.15	38.3	1.35			
65	29.3	1.85																					
(°)	64 ~ 81.5	67 ~ 81.5		67 ~ 81.5		67 ~ 81.5		67 ~ 81.5		67 ~ 81.5		67 ~ 81.5		67 ~ 81.5		67 ~ 81.5		67 ~ 81.5		69 ~ 81.5		69 ~ 81.5	

Performance G (Counterweight 12 t, Outrigger extension width 5.3 m)

Boom length		53.1 m boom + Fully automatic jib						21.5 m jib														
Jib length		9.9 m jib			15.7 m jib			21.5 m jib			21.5 m jib											
Offset boom angle (°)	Working radius(m)	Total rated loads	2.5 °	5 °	6.0 °	6.0 °	2.5 °	5 °	6.0 °	6.0 °	2.5 °	5 °	4.5 °	6.0 °								
			Working radius(m)	Total rated loads	Working radius(m)	Total rated loads	Working radius(m)	Total rated loads	Working radius(m)	Total rated loads	Working radius(m)	Total rated loads	Working radius(m)	Total rated loads	Working radius(m)	Total rated loads						
81.5	9.4	7.0	12.5	7.0	14.5	6.2	15.3	5.8	16.0	3.65	19.0	2.5	20.3	2.15	22.7	2.8	19.5	2.0	23.9	1.3	25.8	1.05
80	11.3	7.0	14.4	7.0	16.3	6.1	17.0	5.7	17.8	3.45	20.7	2.4	22.0	2.1	15.0	2.8	21.5	1.85	25.7	1.25	27.5	1.05
79	12.6	7.0	15.7	6.9	17.4	6.0	18.1	5.65	19.1	3.35	21.9	2.35	23.1	2.1	16.6	2.8	22.8	1.8	26.9	1.2	28.6	1.05
78	13.9	7.0	16.9	6.75	18.6	5.95	19.2	5.6	20.4	3.25	23.1	2.35	24.2	2.05	18.1	2.8	24.2	1.75	28.2	1.2	29.7	1.0
75	17.5	6.15	19.9	5.15	21.5	4.55	22.0	4.3	20.1	4.4	24.0	3.05	26.5	2.25	22.5	2.8	28.0	1.6	31.6	1.15	32.9	1.0
73	19.4	4.45	21.7	3.75	23.2	3.35	23.7	3.15	22.5	4.0	26.4	2.9	28.7	2.2	25.4	2.75	30.6	1.55				
(°)	72~81.5		72~81.5		72~81.5		72~81.5		72~81.5		72~81.5		72~81.5		72~81.5		72~81.5		74~81.5		74~81.5	

Unit: ton

Boom length		56.0 m boom + Fully automatic jib						21.5 m jib																
Jib length		9.9 m jib			15.7 m jib			21.5 m jib			21.5 m jib													
Offset boom angle (°)	Working radius(m)	Total rated loads	2.5 °	5 °	6.0 °	6.0 °	2.5 °	5 °	6.0 °	6.0 °	2.5 °	5 °	4.5 °	6.0 °										
			Working radius(m)	Total rated loads	Working radius(m)	Total rated loads	Working radius(m)	Total rated loads	Working radius(m)	Total rated loads	Working radius(m)	Total rated loads	Working radius(m)	Total rated loads	Working radius(m)	Total rated loads								
81.5	10.0	6.2	13.2	6.2	15.4	6.2	16.2	5.75	11.7	4.0	16.8	3.6	19.8	2.45	21.1	2.15	13.3	2.5	20.3	1.95	24.6	1.25	26.5	1.05
80	12.1	6.2	15.2	6.2	17.3	6.05	17.9	5.65	13.9	4.0	18.8	3.4	21.6	2.4	22.9	2.1	15.8	2.5	22.4	1.85	26.6	1.2	28.3	1.05
79	13.5	6.2	16.5	6.2	18.5	6.0	19.2	5.65	15.4	4.0	20.1	3.3	22.9	2.35	24.0	2.05	17.4	2.5	23.9	1.8	27.9	1.2	29.5	1.0
78	14.9	6.2	17.9	6.2	19.7	5.9	20.3	5.6	16.9	4.0	21.5	3.2	24.1	2.3	25.2	2.05	19.0	2.5	25.2	1.7	29.1	1.15	30.7	1.0
75	18.5	5.05	20.9	4.25	22.5	3.75	23.0	3.55	21.2	4.0	25.3	3.0	27.7	2.2	28.5	2.0	23.6	2.5	29.3	1.6				
73	20.5	3.5																						
(°)	72~81.5		74~81.5		74~81.5		74~81.5		74~81.5		74~81.5		74~81.5		74~81.5		74~81.5		74~81.5		77~81.5		77~81.5	

Unit: ton

TOTAL RATED LOADS

1. The total rated loads shown are for the case where the outriggers are set horizontally on firm level ground. The values above the bold lines are based on the crane strength while those below are based on the crane stability.
2. The weights of the slings and hooks (150t hook with an attachment sheave: 1,850kg, 150t hook: 1,500kg, 50t hook: 750kg, 8t hook: 250kg) are included in the total rated loads shown.
3. The total rated load is based on the actual working radius including the deflection of the boom.
4. The table below shows the classification of Performances A to I of the total rated load.

Counterweight Outrigger extension width	28 t	23 t	12 t	4 t or 0 t
8.0 m	A	B	D	G *
7.0 m	B	C	E	G *
5.3 m	D	F	G	H *
4.6 m	F *	G *	H *	H *
2.68m	/	/	/	I *

- Even for the same classification of performance/boom length, the total rated load varies depending on the boom extending condition.
 - Performances with * are only for the boom performance .
 - Performance I is available for the 32.8 m boom or shorter booms.
5. The bottom line of the table shows the standard number of part lines for each boom length.
When using with other than this number of part lines, the load per line should not exceed 8.0 t for the main winch and the auxiliary winch.
 - A number of part lines is one (8 t hook is used) when the single top or jib is used.
 - When a number of part lines is 21, use the attachment sheave, single top, and main and auxiliary winches.
Otherwise, the maximum number of part lines will be 12.
 6. The total rated load for the single top shall be the value obtained by subtracting the weight of the hook mounted to the boom from the total rated load of the boom and must not exceed 8.0t.
 7. The total rated load for the jib differs for boom lengths of less than 53.1 m and 56.0 m.
 8. Jib operation should be performed on the basis of the boom angle. The working radii are reference values for the case where a jib is mounted to a 53.1m or 56.0m boom.
 9. Mark in the total rated load chart shows the boom angle range (under no load)
 10. When the maximum instantaneous velocity is 10m/s or more, stop crane operation.

WORKING RADIUS - LIFTING HEIGHT

Performance A (1)

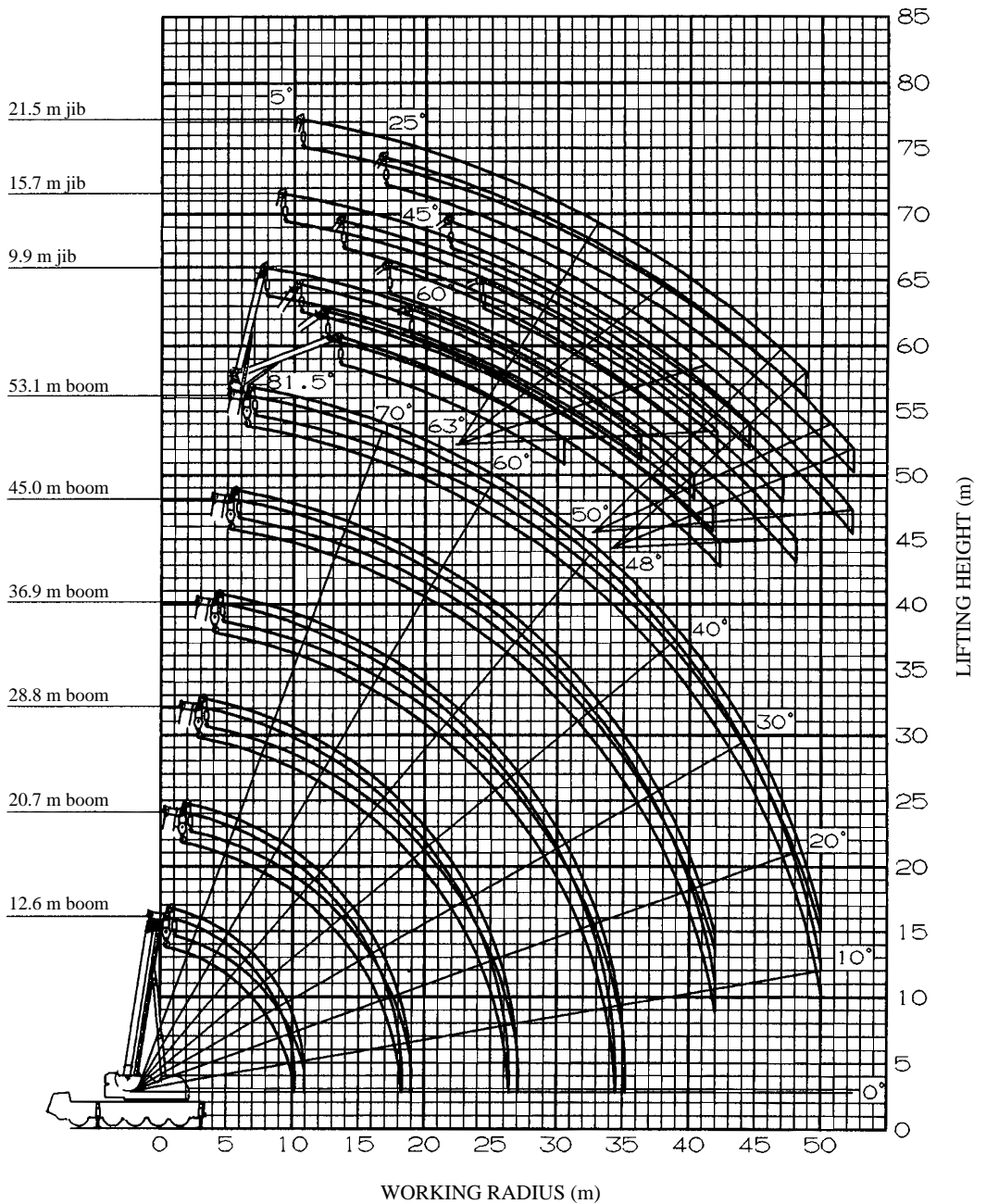

NOTES:

1. The deflection of the boom is not incorporated in the figure above.
2. The above figure is maximum load radius for Performance A.

Performance A (2)

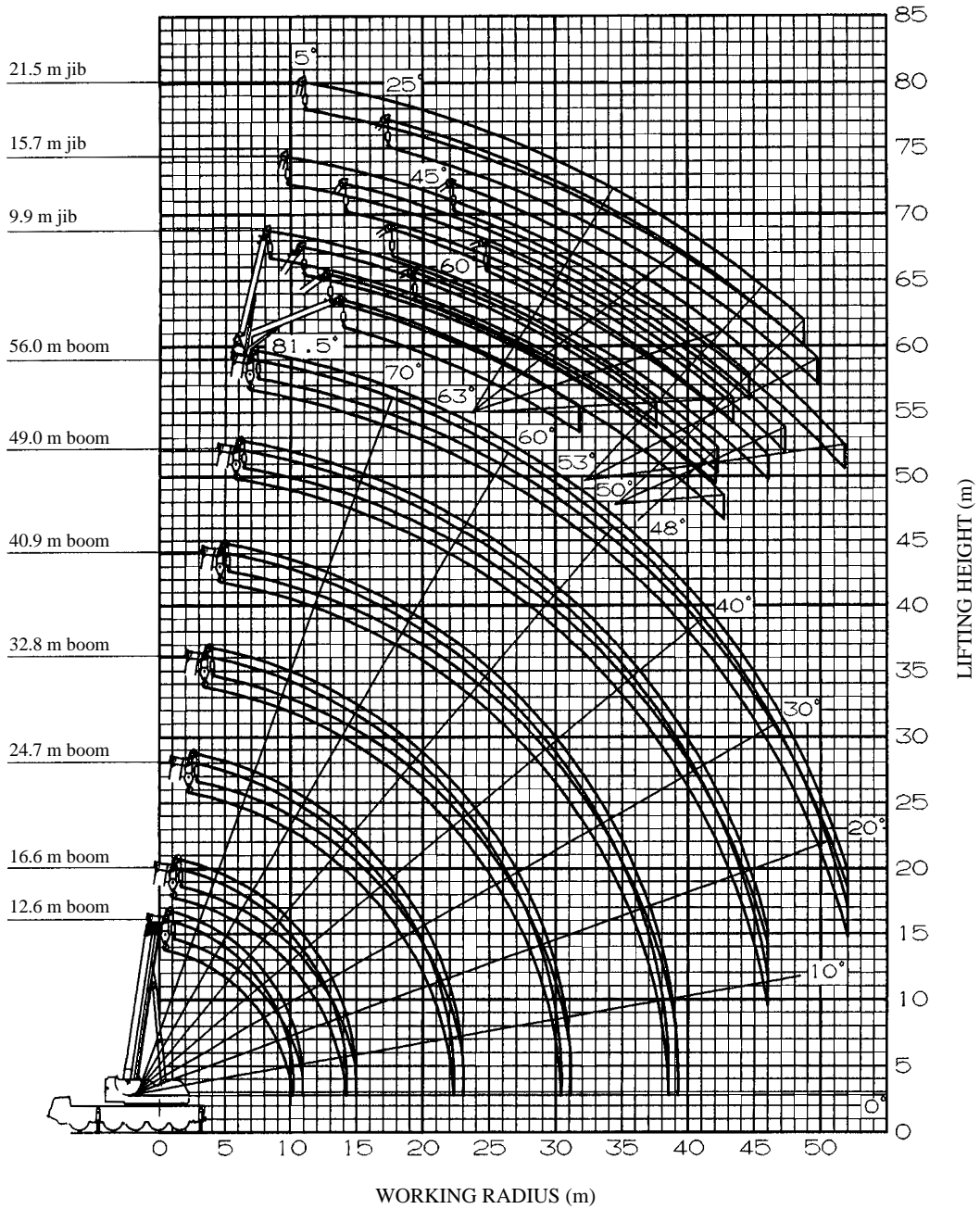

NOTES:

1. The deflection of the boom is not incorporated in the figure above.
2. The above figure is maximum load radius for Performance A.

DIMENSIONS (1/100)

[On public thoroughfare traveling condition]

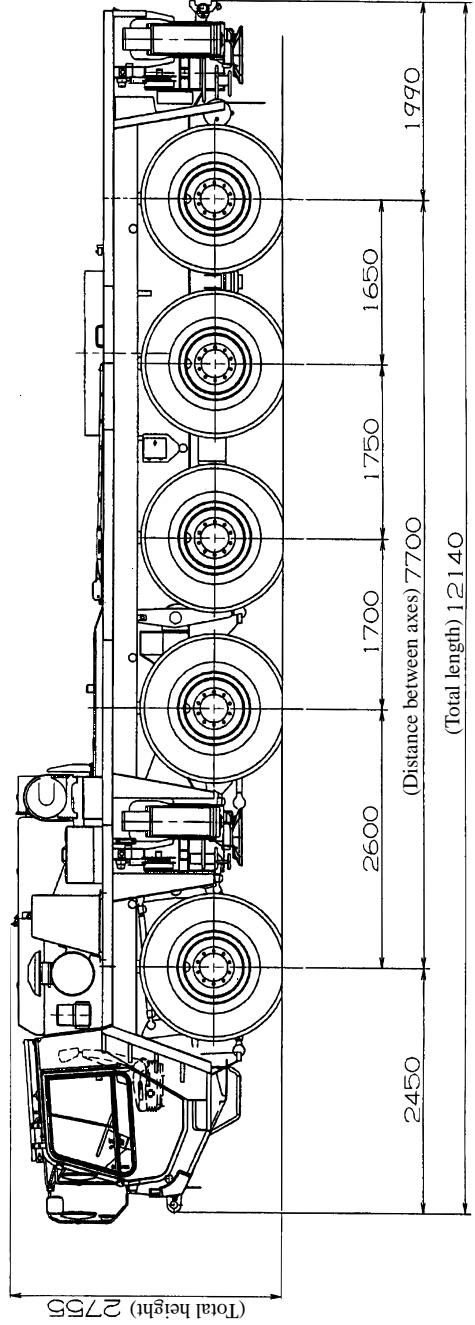
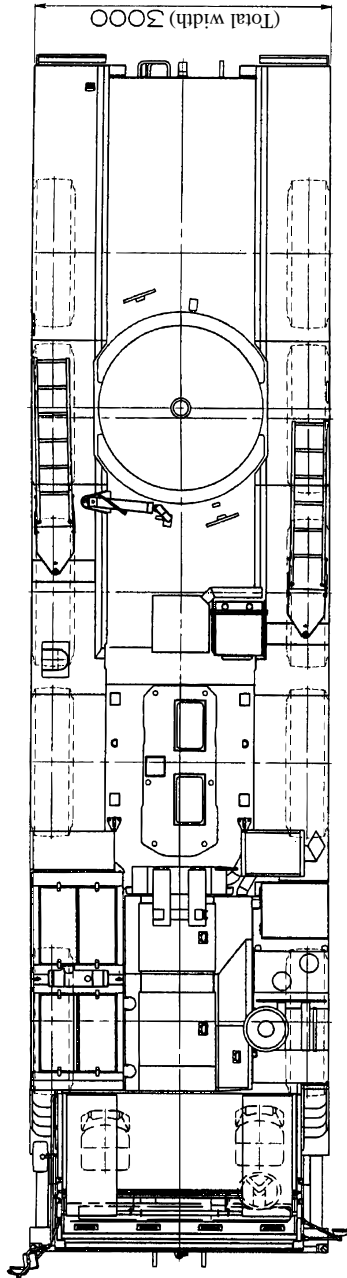

DIMENSIONS (1/100)

[On-site traveling condition]

