

4450

SERIES B

Self-Propelled Hydraulic Crane

55-Ton

**Capacities
Specifications
Operating Ranges**



DIVISION OF BURRO-BADGER CORPORATION

80' BOOM — 4450 SERIES B CRANE LOAD CHART PCSA CLASS 10-180
55 TON CAPACITY FULLY HYDRAULIC SELF-PROPELLED CRANE

ON OUTRIGGERS FULLY EXTENDED—360° (a)

RADIUS IN FEET	BOOM LENGTH										30 FT SIDEFLY PLUS 80.8 FT BOOM	RADIUS IN FEET						
	32.3 FEET		40 FEET		48 FEET		56 FEET		64 FEET				72 FEET		80.8 FEET		110 FEET	
	▲°	LBS	▲°	LBS	▲°	LBS	▲°	LBS	▲°	LBS			▲°	LBS	▲°	LBS	▲°	LBS
10	63	110,000	68	75,800	72	74,000	75	72,800	73	69,400	75	61,000	74	49,500				10
12	59	94,400	65	75,800	70	73,300	73	69,400	73	66,400	75	61,000	74	49,500				12
15	52	74,900	60	75,400	66	65,700	69	61,100	72	55,000								15
20	44	54,800	52	55,300	59	53,500	64	49,900	67	46,400	70	41,800	72	35,200				20
25	38	41,800	42	42,500	52	42,800	58	40,300	62	38,300	66	35,300	68	30,700	74	18,500		25
30			29	31,300	44	31,900	52	31,900	57	32,200	61	30,100	65	26,700	71	16,300		30
35			1	22,500	34	23,400	45	23,800	52	24,100	57	24,400	61	22,800	68	14,800		35
40					21	18,900	37	18,500	46	19,200	52	19,000	56	19,300	65	13,200		40
45							27	14,700	39	15,000	46	15,200	52	15,400	62	12,100		45
50							11	11,800	31	12,200	40	12,400	47	12,600	58	11,100		50
55									34	10,200	34	10,200	42	10,400	54	10,200		55
60									26	8,440	26	8,440	37	8,640	53	8,230		60
65											14	6,970	30	7,200	50	6,240		65
70													22	5,980	46	5,370		70
75													9	4,910	43	4,340		75
80															39	3,460		80
85															35	4,690		85
90															30	4,020		90
95															24	3,420		95
100															17	2,880		100
105															2	2,360		105

ON OUTRIGGERS FULLY EXTENDED—OVER FRONT (a)

RADIUS IN FEET	BOOM LENGTH										30 FT SIDEFLY PLUS 80.8 FT BOOM	RADIUS IN FEET						
	32.3 FEET		40 FEET		48 FEET		56 FEET		64 FEET				72 FEET		80.8 FEET		110 FEET	
	▲°	LBS	▲°	LBS	▲°	LBS	▲°	LBS	▲°	LBS			▲°	LBS	▲°	LBS	▲°	LBS
10	63	110,000	68	75,800	72	74,000	75	72,800	73	69,400	75	61,000	74	49,500				10
12	59	94,400	65	75,800	70	73,300	73	69,400	73	66,400	75	61,000	74	49,500				12
15	52	74,900	60	75,400	66	65,700	69	61,100	72	55,000								15
20	44	54,800	52	55,300	59	53,500	64	49,900	67	46,400	70	41,800	72	35,200				20
25	38	41,800	42	42,500	52	42,800	58	40,300	62	38,300	66	35,300	68	30,700	74	18,500		25
30			29	31,300	44	31,900	52	31,900	57	32,200	61	30,100	65	26,700	71	16,300		30
35			1	23,000	34	23,800	45	24,200	52	24,500	57	24,800	61	22,800	68	14,800		35
40					21	18,500	37	18,900	46	19,200	52	19,400	56	19,700	65	13,200		40
45							27	15,200	39	15,400	46	15,700	52	15,900	62	12,100		45
50							11	12,300	31	12,600	40	12,800	47	13,000	58	11,100		50
55									34	10,500	34	10,700	42	10,900	54	10,200		55
60									26	8,940	26	8,940	37	9,120	53	8,230		60
65											14	7,480	30	7,700	50	6,240		65
70													22	6,500	46	5,370		70
75													9	5,450	43	4,340		75
80															39	3,460		80
85															35	5,310		85
90															30	4,620		90
95															24	4,020		95
100															17	3,470		100
105															2	2,940		105

ON RUBBER CAPACITIES (a)

FOR 26.5 x 25-26PR TIRES (f)

RADIUS IN FEET	STATIONARY		PICK & CARRY (b)			
	OVER FRONT	360° ROTATION	CREEP SPEED (c)		5 MPH	
			2.5 MPH	5 MPH	2.5 MPH	5 MPH
10	54 800	44 100	54 800	37 800	30 200	30 200
12	46 400	33 100	47 800	32 800	25 800	25 800
15	41 100	22 300	39,500	26 800	20 800	20 800
20	28 100	13 300	28 100	19 700	15 000	15 000
25	18 800	8 550	18 800	15 000	11 000	11 000
30	13 800	6 170	13 800	12 000	8 630	8 630
35	10 000	4 020	10 000	9 270	6 280	6 280
40	8 050	3 040	8 050	7 710	5 050	5 050
45	6 460	2 170	6 460	6 310	3 910	3 910
50	4 940	1 260	4 940	4 820	2 730	2 730
55	4 020		4 020	4 000	1,990	1,990

MAXIMUM ALLOWABLE BOOM LENGTH - 64 FEET

WEIGHT REDUCTIONS FOR BOOM EXTENSIONS

30 FT.	SIDEFLY BOOM EXTENSION (e) STORED-650 LBS. (e) ERECTED-1530 LBS.
25 FT.	JIB (e) STORED-200 LBS. (e) ERECTED-1670 LBS.

JIB CAPACITY

30 FT. MAIN BOOM ANGLE	SIDEFLY PLUS 25 FT. COMBINATION (d)	JIB
77°	8 500	4 200
70°	7 220	3 600
60°	5 700	3 300
50°	4 740	3 120
40°	3 750	2 800

TACKLE REEVING MAIN WINCH

NO. OF PARTS OF HOIST TACKLE	MAX. HOOK LOAD LBS.
1	11 000
2	22 000
3	33 000
4	44 000
5	55 000
6	66 000
7	77 000
8	88 000
9	99 000
10	110 000

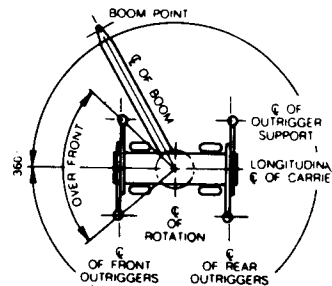

- (a) Refer to area of operation chart for defined working arc.
- (b) Mechanical house lock pin must be fully engaged.
- (c) Travel resulting in not more than 200 ft. covered in a 30 minute period.
- (d) Boom must be fully extended when lifting with extended power pin section or with 30 ft. sidefly.
- (e) Reduction in main boom capacities.
- (f) Refer to tire inflation chart.

Side Fly is a registered trademark.

ON OUTRIGGERS

fully-enclosed all steel cab with safety glass windows, removable front window, hinged daylight and rear window, electric windshield wiper and washer, defroster fan, dome light, fire extinguisher, fully adjustable air cushioned seat, seat belt.
Propane or diesel heater optional.

CONTROLS

Five levers for all boom, winch, and swing movements. One foot pedal, linked to boom raise and lower lever. Dead-man type (except swing) are self-centering when controls are released, machine movements stop automatically. Swing brake, with free swing. Machine leveling gauge, electric horn, mechanical house lock, emergency brake, parking brake.

Key-operated ignition switch with indicator light, starter button, foot throttle, fuel gauge, voltmeter, hour meter. Gauges for engine oil pressure, transmission oil pressure, transmission oil temperature, engine coolant temperature, air pressure. Hydraulic filter and low air warning lights.

MAIN WINCH

Model 34 Hydraulic powered up and down

Speed—fpm (m/min)

Wrap	Maximum Line Speed		Line Pull Lbs (kg)
	Full Load	No Load	
1	260 (79.2)	312 (95.1)	13,950 (6,328)
2	278 (84.7)	334 (101.8)	13,100 (5,942)
3	295 (89.9)	354 (107.9)	12,350 (5,602)
4	312 (95.1)	374 (114)	11,670 (5,294)
5	329 (100.3)	395 (120.4)	11,070 (5,021)

Optional 2-speed main winch.

High Speed—fpm (m/min)

Wrap	Maximum Line Speed		Line Pull Lbs (kg)
	Full Load	No Load	
1	476 (145.1)	571 (174)	7,670 (3,479)
2	510 (155.4)	612 (186.5)	7,160 (3,248)
3	544 (165.8)	653 (199)	6,710 (3,044)
4	578 (176.2)	694 (211.5)	6,310 (2,862)
5	612 (186.5)	734 (223.7)	5,960 (2,703)

Low Speed—fpm (m/min)

Wrap	Maximum Line Speed		Line Pull Lbs (kg)
	Full Load	No Load	
1	258 (72.5)	286 (87.2)	15,340 (6,953)
2	255 (77.7)	306 (93.3)	14,310 (6,491)
3	272 (82.9)	326 (99.4)	13,420 (6,067)
4	289 (88.1)	347 (105.8)	12,630 (5,729)
5	306 (93.3)	367 (111.9)	11,920 (5,407)

Either winch includes 450' (137 m) of 5/8" (15.9 mm) cable. Free fall optional with either main winch.

Fluid capacities in U.S. gallons. Specifications subject to change without notice.

(Model 25) Hydraulic powered up and down with optional free fall.
Speed—fpm (m/min)

Wrap	Maximum Line Speed		Line Pull Lbs (kg)
	Full Load	No Load	
1	227 (69.2)	272 (82.9)	6,445 (2,923)
2	245 (74.7)	294 (89.6)	5,950 (2,699)
3	265 (80.8)	318 (96.9)	5,530 (2,508)
4	283 (86.3)	340 (103.6)	5,170 (2,345)

Optional: 450' (137 m) of 1/2" (12.7 mm) cable.

WIRE ROPE

All winch cable is preformed wire rope, 6x25 strands, right-regular lay, EIPS, steel core.

SWING

Planetary, with internal brake. Spring set, hydraulic release. Free swing or automatic brake. Speed—3 rpm.

ENGINE

GM 6V-53N diesel, 6 cyl ohv, 2 cycle, 197 hp at 2600 rpm, 318 cid (5.21), 3.875" bore x 4.5" stroke (98 mm x 114 mm), 21:1 compression ratio, 431 ft-lbs (59.8 mkg) max torque at 1500 rpm.

Electric starter, 12-volt 65 amp alternator, 3 90-amp batteries.

Air compressor, 12 cfm (5.7 l/sec).

Optional engine: Cummins V-555C230 diesel, 8 cyl ohv, 4 cycle, 207 hp at 2,800 rpm, 555 cid (9.1 l), 4-5/8" bore x 4-1/8" stroke (117 mm x 105 mm), 17-1 compression ratio, 425 ft-lbs (58.8 mkg) max torque at 1800 rpm. Electric starter, 12-volt 60 amp alternator, 3 90-amp batteries.

Air compressor, 13.2 cfm (6.2 l/sec).

Fuel capacity, either engine 130 gal (492 l)

TRANSMISSION

Six-speed with rear axle disconnect. Electric three speed range and directional shift with electric over air high low shift and rear axle disconnect.

Drive	Transmission Range	Gear Shift	Maximum Speed mph (km/hr)
4-wheel	Low	1st	1.6 (2.5)
4-wheel	Low	2nd	3.3 (5.3)
4-wheel	Low	3rd	8.8 (14)
2-wheel	High	1st	4.5 (7.2)
2-wheel	High	2nd	9.2 (14.8)
2-wheel	High	3rd	22.7 (36.5)

GRADEABILITY: NOTE: All performance data is based on standard machines, and may vary due to engine performance and optional equipment. Machine should be operated within a 30° slope limitation due to engine lubrication design.

AXLES

Ratio 22.4:1. Planetary steering. Front axle rigidly mounted to frame. Rear axle pinned for oscillation, automatic oscillation lockout, with manual override. Non-spin differential optional.

Four-wheel air service brakes. Drums 20.25" x 4" (514 mm x 102 mm). Spring-set emergency and parking brakes on all four wheels.

TIRES

26.5 x 25 26-ply, 22 25 rim.

Optional:

29.5 x 25 22-ply, 25 x 25 rim.

Spare tire, tire inflation kit.

STEERING

Two independent systems. Front, hydrostatic controlled by Char-Lynn orbitrol unit. Rear, hydrostatic controlled by toggle switch on dash panel, with rear-wheel centering indicator light. Turning radius.

Front-wheel steering: 38' (11.6m).

Four-wheel coordinated 21' 6" (6.6m).

OUTRIGGERS

Beam type, hydraulic powered, 24" (61 cm) diameter floats. 21' (6.4 m) spread center-to-center of jacks.

Optional: 30" (76 cm) floats.

WEIGHT — Lbs (kg)	Front Axle		Rear Axle	
	80' boom	105' boom	80' boom	105' boom
	77,500 (35,154)	79,700 (36,152)	40,200 (18,235)	43,500 (19,732)
			37,300 (16,919)	36,200 (16,420)

STANDARD EQUIPMENT

Dual headlights, tail lights, brake lights, back-up lights, turn signals, parking lights, front and rear fenders, tow loops, rear view mirrors, electronic boom angle indicator.

OPTIONAL EQUIPMENT

Jib: 25' (7.6 m) self-storing. Can only be erected to the end of the Side Fly.

Deluxe boom angle indicator. Electronic, with adjustable limit settings and audible warning.

Anti-Two block system. Electric-hydraulic, for boom, Side Fly, or jib. Stops boom lower, boom extend, winch up movements automatically, audible and visual warning signals in cab, manual override. Also available with audible and visual warning signals only, without automatic stop.

Working lights: On front of cab and on boom.

Rotating amber beacon: On top of cab.

Vandalism protection package: Padlocks for access and storage doors, fuel tank, Lexan windows.

Tow winch: Model PD-15, mounted on front of frame, controlled from cab. Line pull 15,000 lbs (680 kg).

Rooster sheave, 55-ton 5-sheave hook block, 15 ton single sheave hook block, headache ball with 5-ton swivel hook, headache ball with 3-ton swivel hook for auxiliary winch, drum rotation indicators for main and auxiliary winches, front and rear pintle hooks, electronic back-up alarm, cold-weather starting kit with extra batteries, electric heating element for hydraulic reservoir.

BADGER CONSTRUCTION EQUIPMENT CO

DIVISION OF BURRO-BADGER CORPORATION

Airport Industrial Park, P. O. Box 168

1000 22nd St., St. Joseph, MO 64501

Form 7325
(Replaces 7818)

10/79-5M-WSC
Printed in U.S.A.



TOTAL P. 06

BADGER 4450

DIMENSIONS, AXLE LOADS

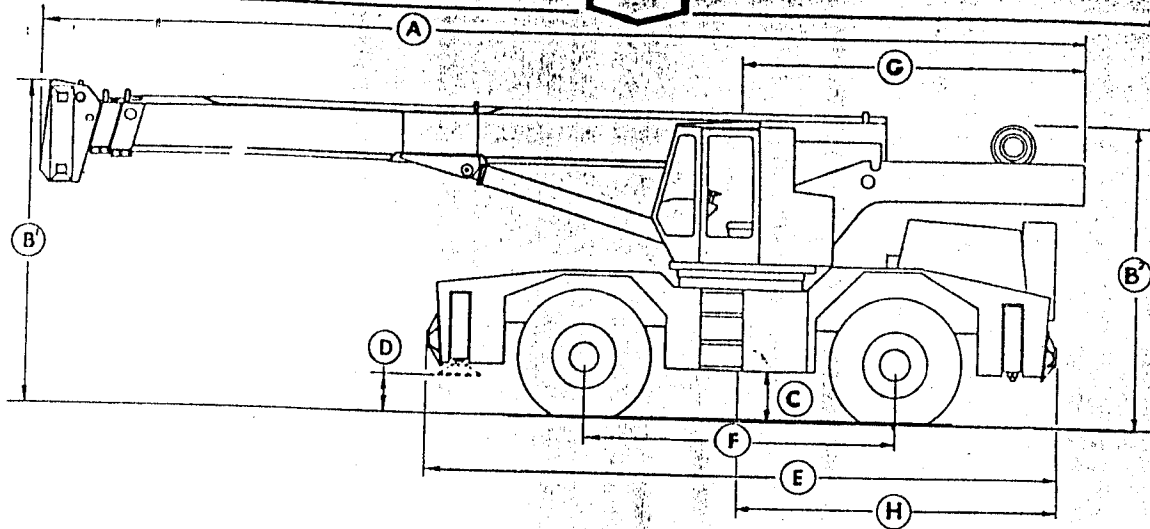

A — Overall length, travel position — With 80' (24.4m) 41' 11" (12.77m)
 With 105' (32 m) 42' 6" (12.95m)

B1—Overall height boom at 00	26.5 x 25 tires	29.5 x 25 tires
B2—Overall height, travel position	12' 7" (3.84 m)	12' 8.5" (3.87 m)
C—Ground clearance	12' 2" (3.66 m)	12' 3.5" (3.75 m)
D—Clearance under outrigger floats, jacks retracted	26½" (67 cm)	29½" (75 cm)
Overall width, travel position	11" (28 cm)	13" (33 cm)
	10'7" (3.2 m)	10'10" (3.3 m)

E—Overall length of undercarriage: 26'5" (8.05 m)

F—Wheelbase: 150" (3.8 m)

G—Tail swing, 13'11" (4.24 m)

H—12'7" (3.83 m)

Outrigger spread, center-to-center of jacks: 21' (6.4 m)

Overall width with floats installed, outrigger beams retracted: 11'3" (3.4 m)

AXLE LOADS — lbs. (kg)		Weight	Front Axle	Rear Axle
Standard Machine	With 80' Boom	77,500 (35,154)	40,200 (18,235)	37,300 (16,919)
	With 105' Boom	79,700 (36,152)	43,500 (19,732)	36,200 (16,420)
	Main winch w/free fall	+300 (+136)	-118 (-54)	+418 (+190)
	Main winch w/2 spd	+120 (+54)	-47 (-21)	+167 (+76)
	Main winch w/2spd & ff	+420 (+191)	-165 (-75)	+585 (+265)
	Aux winch	+625 (+284)	-348 (-158)	+973 (+441)
	Aux winch w/free fall	+875 (+397)	-487 (-221)	+1362 (+618)
	30' Sidefly	+1300 (+590)	+2302 (+1044)	-978 (-444)
	25' Jib	+1020 (+463)	+1264 (+573)	-224 (-102)
	Aux. boom head	+100 (+45)	+280 (+127)	-180 (-82)
	Five sheave hook block	+620 (+281)	+620 (+281)	
	Single sheave block	+60 (+27)	+60 (+27)	
	Headache ball, 5 ton block	+250 (+113)	+250 (+113)	
	Headache ball, 3 ton block	+200 (+91)	+200 (+91)	
	Front pintle hook	+35 (+16)	+51 (+23)	
	Rear Pintle hook	+35 (+16)	-16 (-7)	
	Tow winch w/o rope	+400 (+181)	+600 (+272)	-200 (-91)
	26.5x25 26P (1500# ea)	STD	STD	STD
	29.5x25 22P (1750# ea)	+2800 (+1270)	+500 (+227)	-500 (+227)

NOTE: Standard machine includes 6,800 lbs. counterweight.
 Weight distribution for hook blocks and headache balls are with these items in storage compartment.
 All weights are estimated.

BADGER CONSTRUCTION EQUIPMENT CO.

DIVISION OF BURRO-BADGER CORPORATION

Airport Industrial Park, P.O. Box 168

WINONA, MN 55987

507-454-1563

11/79 - 15M - W&C
 Printed in U.S.A.

**105' BOOM — MODEL 4450 SERIES B CRANE LOAD CHART PCSA CLASS 10-173
55 TON CAPACITY FULLY HYDRAULIC SELF-PROPELLED CRANE**

ON OUTRIGGERS FULLY EXTENDED—360° (a)

RADIUS IN FEET	BOOM LENGTH												POWER PIN SECTION EXTENDED (d)	30 FOOT SIDEFLY PLUS 81.4 FT. BOOM	30 FOOT SIDEFLY PLUS 105 FT. BOOM	RADIUS IN FEET			
	32.8 FEET		40 FEET		48 FEET		56 FEET		64 FEET		72 FEET						81.4 FEET		
	▲°	LBS.	▲°	LBS.	▲°	LBS.	▲°	LBS.	▲°	LBS.	▲°	LBS.					▲°	LBS.	
10	83	110,000	68	74,000	72	72,100	75	71,000	75	69,000	75	68,000	75	66,000			10		
12	58	94,000	65	74,000	70	72,100	73	67,600	75	66,000	75	65,000	75	63,000			12		
15	53	74,400	65	74,000	66	64,800	68	59,600	72	53,700	75	48,300					15		
20	41	54,200	52	54,400	58	52,300	64	48,700	67	45,300	70	40,800	72	35,200			20		
25	28	41,200	42	41,500	52	41,700	58	39,600	62	38,000	68	34,200	70	30,700	74	21,100	25		
30			29	30,500	44	31,000	52	31,300	57	31,600	61	28,900	65	26,700	71	18,900	30		
35			1	22,000	34	22,800	45	23,100	52	23,300	57	23,600	61	22,900	68	17,800	35		
40					21	17,300	37	17,700	46	17,900	52	18,100	57	18,300	65	15,700	40		
45							27	13,800	39	14,000	46	14,200	52	14,400	62	13,900	45		
50							11	10,900	31	11,200	40	11,300	48	11,500	56	12,300	50		
55									21	8,900	34	9,100	43	9,260	55	10,800	55		
60											26	7,300	37	7,470	52	9,300	60		
65											14	5,790	31	6,000	48	7,870	65		
70													23	4,760	45	6,600	70		
75													11	3,670	41	5,540	75		
80															36	4,620	80		
85															31	3,820	85		
90															25	3,120	90		
95															18	2,480	95		
100															2	1,850	100		
105																18	2,600	105	
110																6	1,510	110	
115																	31	1,770	115
120																	26	1,400	120
																	21	1,060	120

ON OUTRIGGERS FULLY EXTENDED—OVER FRONT (a)

RADIUS IN FEET	BOOM LENGTH												POWER PIN SECTION EXTENDED (d)	30 FOOT SIDEFLY PLUS 81.4 FT. BOOM	30 FOOT SIDEFLY PLUS 105 FT. BOOM	RADIUS IN FEET			
	32.8 FEET		40 FEET		48 FEET		56 FEET		64 FEET		72 FEET						81.4 FEET		
	▲°	LBS.	▲°	LBS.	▲°	LBS.	▲°	LBS.	▲°	LBS.	▲°	LBS.					▲°	LBS.	
10	83	110,000	68	74,000	72	72,100	75	71,000	75	69,000	75	68,000	75	66,000			10		
12	58	94,000	65	74,000	70	72,100	73	67,600	75	66,000	75	65,000	75	63,000			12		
15	53	74,400	65	74,000	66	64,800	68	59,600	72	53,700	75	48,300					15		
20	41	54,200	52	54,400	58	52,300	64	48,700	67	45,300	70	40,800	72	35,200	74	21,100	20		
25	28	41,200	42	41,500	52	41,700	58	39,600	62	38,000	68	34,200	70	30,700	74	18,900	25		
30			29	31,100	44	31,500	52	31,900	57	31,600	61	28,900	65	26,700	71	18,900	30		
35			1	22,600	34	23,300	45	23,600	52	23,900	57	24,100	61	22,900	68	17,800	35		
40					21	17,900	37	18,200	46	18,400	52	18,600	57	18,800	65	15,700	40		
45							27	14,400	39	14,600	46	14,800	52	15,000	62	13,900	45		
50							11	11,500	31	11,800	40	11,900	48	12,100	56	12,300	50		
55									21	9,500	34	9,710	43	9,870	55	10,800	55		
60											26	7,940	37	8,100	52	9,800	60		
65											14	6,450	31	6,650	48	8,500	65		
70													23	5,440	45	7,300	70		
75													11	4,370	41	6,220	75		
80															36	5,290	80		
85															31	4,490	85		
90															25	3,780	90		
95															18	3,140	95		
100															2	2,510	100		
105																18	2,710	105	
110																6	2,170	110	
115																	31	2,480	115
120																	26	2,070	120
125																	21	1,700	125
																	14	1,350	125

JIB CAPACITY

MAIN BOOM ANGLE	30 FT. SIDEFLY PLUS 25 FT. COMBINATION (d)		JIB
	0° JIB OFFSET LBS.	15° JIB OFFSET LBS.	
77°	6 000	5 300	4 200
70°	4 870	4 070	3 000
68°	4 000	3 070	3 000
60°	3 500	3 310	3 130
50°	3 270	3 000	2 900

WEIGHT REDUCTIONS FOR BOOM EXTENSIONS

30 FT. SIDEFLY BOOM EXTENSION	JIB	
		(e) STORED-650 LBS.
25 FT.	(e) STORED-200 LBS.	(e) ERRECTED-1500 LBS.

TACKLE REEVING MAIN WINCH

NO. OF PARTS OF HOIST TACKLE	MAX. LOAD LBS.	HOOK LBS.
1	11 000	
2	22 000	
3	33 000	
4	44 000	
5	55 000	
6	66 000	
7	77 000	
8	88 000	
9	99 000	
10	110 000	

ON RUBBER CAPACITIES (a)

FOR 26.5 x 25-26PR TIRES (1)

RADIUS IN FEET	STATIONARY		PICK & CARRY (b)		
	OVER FRONT	360° ROTATION	CREEP SPEED (c)	2.5 MPH	5 MPH
10	54 200	43 500	53 700	36 900	29 200
12	47 700	33 500	46 800	31 700	24 800
15	40 200	22 400	38 500	25 700	19 900
20	28 200	13 200	28 200	18 800	14 100
25	18 500	8 320	18 500	14 000	10 000
30	13 300	5 630	13 300	10 800	7 410
35	9 420	3 400	9 420	8 010	5 030
40	7 300	2 290	7 300	6 320	3 800
45	5 590	1 320	5 590	4 820	2 420
50	4 040		4 040	3 410	1 230
55	3 030		3 030	2 410	

MAXIMUM ALLOWABLE BOOM LENGTH - 64 FEET

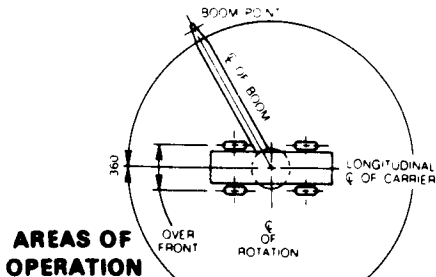

AREAS OF OPERATION

ON RUBBER

- (a) Refer to area of operation chart for defined working arc.
- (b) Mechanical house lock pin must be fully engaged.
- (c) Travel resulting in net more than 200 ft. covered in a 30 minute period.
- (d) Boom must be fully extended when lifting with extended power pin section or with 30 ft. sidefly.
- (e) Reduction in main boom capacities.
- (f) Refer to tire inflation chart.

105' Boom

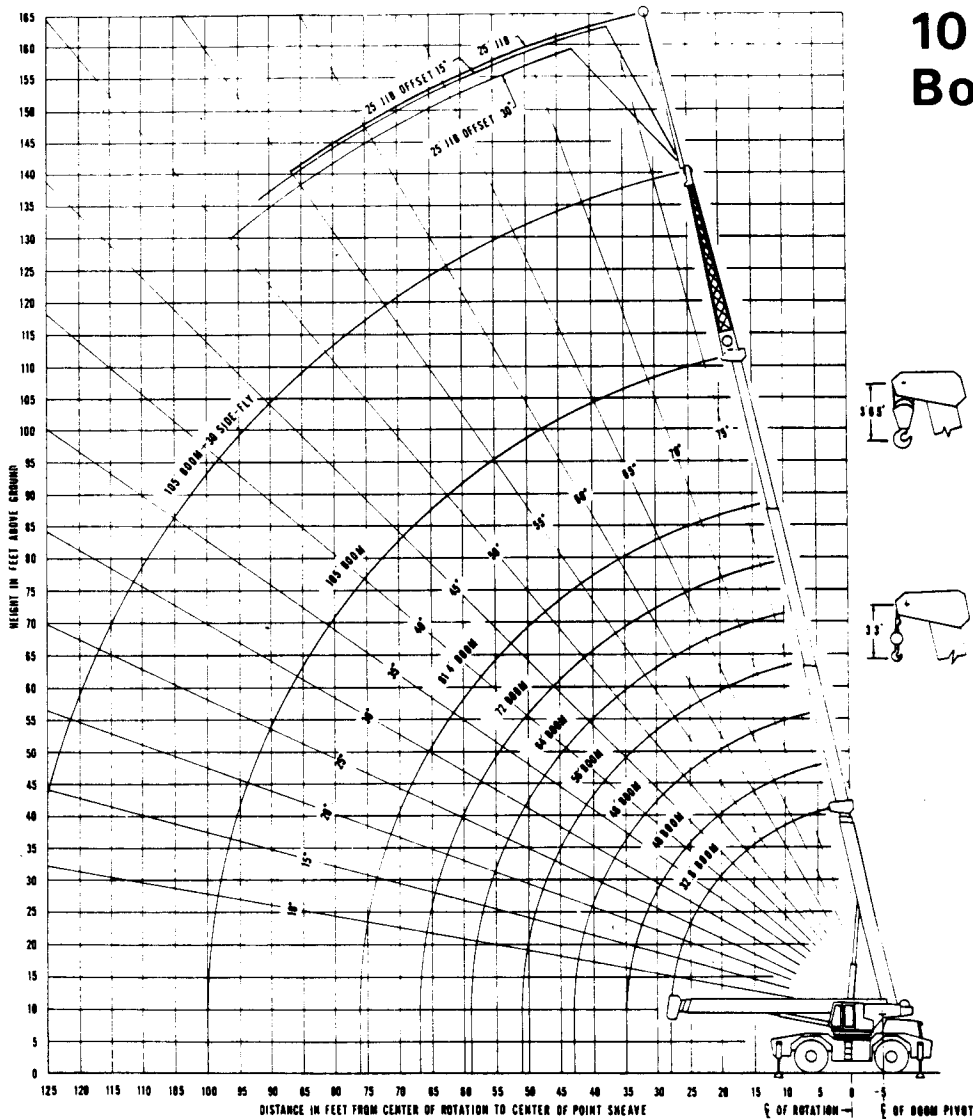

OPERATING INSTRUCTIONS:

Radius of the load is the horizontal distance from a projection of the axis of rotation before loading, to the center of vertical hoist line or tackle with load applied.

Boom angles, which represent the unloaded boom angles, are to be used for reference only. These boom angles must be adjusted to maintain the proper load radius while the load is being picked. Load ratings in shaded areas are based on machine's hydraulic or structural competence and not of the machine's stability. Tipping capacities do not exceed 85% of tipping loads for "on outrigger" capacities and 75% of tipping loads for "on rubber" capacities as determined by tests in accordance with SAE recommended practice—"Crane Load Stability Test Code SAE J765a".

Crane load capacities are based on freely suspended loads. They are the maximum covered by the manufacturer's warranty with the machine leveled and standing on a firm supporting surface. Practical working loads depend upon supporting surface, wind, and other factors affecting stability, hazardous surroundings, experience of personnel, and proper handling; all of which must be taken into account by the operator. The weights of all auxiliary handling devices such as boom attachments, hoist block, hooks, and slings, except hoist rope, shall be considered as part of the load ratings.

All powered boom sections are synchronized to be extended equally at all times. Each section extends to a maximum distance of 24.3 feet. The maximum powered boom load which may be telescoped is limited by hydraulic pressure, boom angle, and boom capacity. It is safe to attempt to telescope any load within the stated conditions of the rating chart.

"On outriggers" capacities are based on outriggers being fully extended to a distance of 21 feet from centerline of vertical jack cylinders.

"On rubber" capacities are based on the tire as specified in the table. Machine must be on a firm and smooth, level surface.

For boom lengths not shown, use load ratings for next longer boom. Positioning or operation at radii and boom lengths beyond the maximums or minimums shown, is not intended or approved.

The boom assembly shall be fully retracted and leveled when crane is out of service.

WARNINGS:

1. Minimum working main boom angle for the fully extended boom plus sidely and jib is 55 degrees. TIPPING can occur rapidly without advance notice.
2. For other boom configurations, having powered sections not fully extended, but with or without sidely; and with or without the jib, the rated loads are found in the columns headed by the maximum length of their respective boom configurations. The boom angle must be used to determine the particular rated load. For boom angles not provided, use the rating of the next lower boom angle.

BADGER 4450 SELF-PROPELLED HYDRAULIC CRANE

SERIES B

ON RUBBER CAPACITIES 29.5x25 - 22 PR TIRES

RATED LIFTING CAPACITIES IN POUNDS

80.8' BOOM

105' BOOM

ON RUBBER CAPACITIES (a)					
FOR 29.5 x 25 - 22 PR TIRES (f)					
RADIUS IN FEET	STATIONARY		PICK & CARRY (b)		
	OVER FRONT	360° ROTATION	CREEP SPEED (c)	2.5 MPH	5 MPH
10	58 800	46 800	46 800	41 900	33 700
12	51 900	33 400	41 300	36 300	28 900
15	44 000	22 500	42 700	29 800	23 500
20	28 400	13 500	28 400	22 300	17 200
25	18 800	8 680	18 800	17 100	12 800
30	14 000	6 270	14 000	13 900	10 200
35	10 200	4 100	10 200	10 200	7 600
40	8 180	3 110	8 180	8 180	6 270
45	6 570	2 240	6 570	6 570	5 020
50	5 040	1 320	5 040	5 040	3 740
55	4 110		4 110	4 110	2 910

MAXIMUM ALLOWABLE BOOM LENGTH - 64 FEET

ON RUBBER CAPACITIES (a)					
FOR 29.5 x 25 - 22 PR TIRES (f)					
RADIUS IN FEET	STATIONARY		PICK & CARRY (b)		
	OVER FRONT	360° ROTATION	CREEP SPEED (c)	2.5 MPH	5 MPH
10	58 800	46 800	57 900	41 000	32 800
12	51 900	33 900	50 800	35 300	28 000
15	43 300	22 700	41 700	28 800	22 500
20	28 500	13 400	28 500	21 300	17 200
25	18 700	8 450	18 700	14 100	11 500
30	13 500	5 730	13 500	12 500	9 180
35	9 570	3 490	9 570	9 570	7 400
40	7 430	2 360	7 430	7 430	5 750
45	5 700	1 390	5 700	5 700	4 520
50	4 140		4 140	4 140	3 230
55	3 120		3 120	3 120	2 330

MAXIMUM ALLOWABLE BOOM LENGTH - 64 FEET

- (a) Refer to area of operation chart for defined working arc.
- (b) Mechanical house lock pin must be fully engaged.
- (c) Travel resulting in not more than 200 ft. covered in a 30 minute period.
- *(d) Boom must be fully extended when lifting with extended power pin section or with 30 ft. sidefly.
- ** (e) Reductions in main boom capacities.
- (f) Refer to tire inflation chart.
- * Refer to jib capacity chart
- ** Refer to weight reductions chart

AREAS OF OPERATION

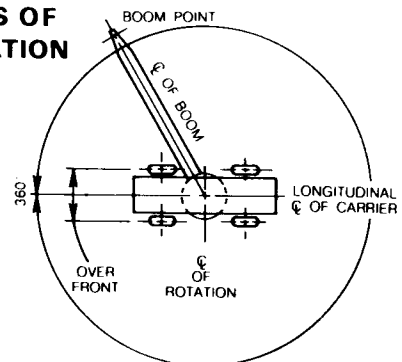

ON RUBBER

TIRE INFLATION

Tire Size	Static Creep	2.5 M.P.H. 5 M.P.H.	Hi-Way
26.5x25 - 26 Ply.	80 P.S.I.	65 P.S.I.	50 P.S.I.
29.5x25 - 22 Ply.	60 P.S.I.	50 P.S.I.	35 P.S.I.

BADGER CONSTRUCTION EQUIPMENT CO.

DIVISION OF BURRO-BADGER CORPORATION

Airport Industrial Park, P.O. Box 168

WINONA, MN 55987

507-454-1563

11/79 - 15M - W&C
Printed in U.S.A.

80' Boom

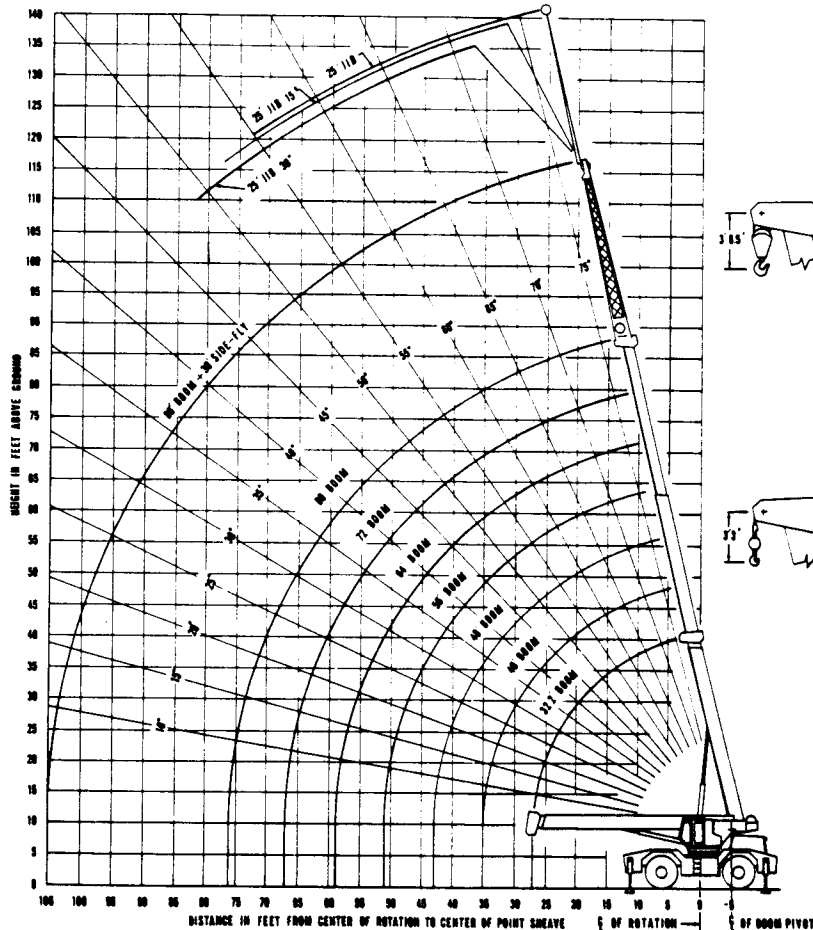

IMPORTANT INSTRUCTIONS

Radius of the load is the horizontal distance from a projection of the axis of rotation before loading, to the center of vertical hoist line or tackle with load applied.

Boom angles, which represent the unloaded boom angles, are to be used for reference only. These boom angles must be adjusted to maintain the proper load radius while the load is being picked.

Load ratings in shaded areas are based on machine's hydraulic or structural competence and not on the machine's stability.

Tipping capacities do not exceed 85% of tipping loads for "on outrigger" capacities or 75% of tipping loads for "on rubber" capacities as determined by tests in accordance with SAE recommended practice - "Crane Load Stability Test Code SAE J-765-a."

Crane load capacities are based on freely suspended loads. They are the maximum covered by the manufacturer's warranty with the machine leveled and standing on a firm supporting surface.

Practical working loads depend upon supporting surface, wind, and other factors affecting stability, hazardous surroundings, experience of personnel, and proper handling, all of which must be taken into account by the operator.

The weights of all auxiliary handling devices such as boom attachments, hoist block, hooks, and slings, except hoist rope, shall be considered as part of the load ratings.

Powered boom sections are synchronized to be extended equally at all times. Each section extends to a maximum distance of 24 feet. The maximum powered boom load which may be telescoped is limited by hydraulic pressure, boom angle, and boom capacity. It is safe to attempt to telescope any load within the stated conditions of the rating chart.

"On outriggers", capacities are based on outriggers being fully extended to a distance of 21 feet from centerline to centerline of vertical jack cylinders.

For boom lengths not shown, use load ratings for next longer boom. Positioning or operation at radii and boom lengths beyond the maximums or minimums shown, is not intended or approved.

From main boom capacities, deduct 650 lbs. when Side Fly stowed, 1,530 lbs. when Side Fly erected, 200 lbs. when jib stowed, 1,670 lbs. when jib erected.

Hoist reeving should be based on 11,000 lbs. per part of line.

HYDRAULIC SYSTEM

Two 2-section tandem pumps, 162 gpm (613 l/min) at 2470 rpm, mounted on torque converter with clutch. Steering pump, 18 gpm (68 l/min).

12 double-acting cylinders:

2 boom hoist: 9" (229 mm) ID
5.5" OD x 3.5" ID (140 mm x 89 mm) rod

2 boom telescoping: 6" (152 mm) ID
5" OD x 4" ID (127 mm x 102 mm) rod

Outrigger cylinders:

4 telescoping: 2.5" ID, 1.5" rod
(64 mm x 38 mm)

4 jack: 6.5" ID, 4.5" rod
(165 mm x 114 mm)

Vane-type swing motor.

Operating pressure: 2500 psi (176 kg/cm²) max.

Pressurized reservoir.

Oil capacity: reservoir 182 gal (689 l), system 300 gal (1,136 l)

Filtration unit built into reservoir: 10-micron disposable element filter with automatic safety relief, built-in magnets, visual indicator on filter housing, indicator lights in engine gauge cluster

Fin and tube type oil cooler.

Main relief valves in all circuits. Holding valves on boom hoist, boom telescoping, and jack cylinders; thermal relief protection in telescope and hoist circuits.

BOOM

80' Boom - Three section. Base section plus two self proportioning hydraulically telescoping sections. Extends to 80' (24.4 m), retracts to 32'6" (9.9 m). Modified hexagon cross-section is self-aligning. Five-sheave head.

105' Boom - Four-section. Base section, two self proportioning hydraulically telescoping section, manually pinned end section. Extends to 105' (32 m), retracts to 32'9" (10 m). Modified hexagon cross-section is self-aligning. Five-sheave head.

Side Fly (optional) - 30' (9.1 m) self-storing boom section, hinged to boom head.

CAB

Fully-enclosed all steel cab with safety glass windows, removable front window, hinged skylight and rear window, electric windshield wiper and washer, defroster fan, dome light, fire extinguisher, fully adjustable air cushioned seat, seat belt.

Propane or diesel heater optional.

CONTROLS

Five levers for all boom, winch, and swing movements. One foot pedal, linked to boom raise-and-lower lever. Dead-man type (except swing) are self-centering when controls are released, machine movements stop automatically. Swing brake, with free swing. Machine leveling gauge, electric horn, mechanical house lock, emergency brake, parking brake.

Key-operated ignition switch with indicator light, starter button, foot throttle, fuel gauge, voltmeter, hour meter. Gauges for engine oil pressure, transmission oil pressure, transmission oil temperature, engine coolant temperature, air pressure. Hydraulic lifter and low air warning lights.

MAIN WINCH

(Model 34) Hydraulic powered up and down.

Speed—fpm (m/min).

Wrap	Maximum Line Speed		Line Pull Lbs (kg)
	Full Load	No Load	
1	260 (79.2)	312 (95.1)	13,950 (6,328)
2	278 (84.7)	334 (101.8)	13,100 (5,942)
3	295 (89.9)	354 (107.9)	12,350 (5,602)
4	312 (95.1)	374 (114)	11,670 (5,294)
5	329 (100.3)	395 (120.4)	11,070 (5,021)

Optional 2-speed main winch.

High Speed—fpm (m/min).

Wrap	Maximum Line Speed		Line Pull Lbs (kg)
	Full Load	No Load	
1	476 (145.1)	571 (174)	7,670 (3,479)
2	510 (155.4)	612 (186.5)	7,160 (3,248)
3	544 (165.8)	653 (199)	6,710 (3,044)
4	578 (176.2)	694 (211.5)	6,310 (2,862)
5	612 (186.5)	734 (223.7)	5,960 (2,703)

Low Speed — fpm (m/min)

Wrap	Maximum Line Speed		Line Pull Lbs (kg)
	Full Load	No Load	
1	238 (72.5)	286 (87.2)	15,340 (6,958)
2	255 (77.7)	306 (93.3)	14,310 (6,491)
3	272 (82.9)	326 (99.4)	13,420 (6,087)
4	289 (88.1)	347 (105.8)	12,630 (5,729)
5	306 (93.3)	367 (111.9)	11,920 (5,407)

Either winch includes 450' (137 m) of 5/8" (15.9 mm) cable. Free fall optional with either main winch.

Fluid capacities in U.S. gallons. Specifications subject to change without notice.

AUXILIARY WINCH (Optional)

(Model 25) Hydraulic powered up and down, with optional free fall.

Speed — fpm (m/min)

Wrap	Maximum Line Speed		Line Pull Lbs (kg)
	Full Load	No Load	
1	227 (69.2)	272 (82.9)	6,445 (2,923)
2	245 (74.7)	294 (89.6)	5,950 (2,699)
3	265 (80.8)	318 (96.9)	5,530 (2,508)
4	283 (86.3)	340 (103.6)	5,170 (2,345)

Optional: 450' (137 m) of 1 2" (12.7 mm) cable

WIRE ROPE

All winch cable is preformed wire rope. 6x25 strands, right-regular lay, EIPS, steel core

SWING

Planetary, with internal brake. Spring set, hydraulic release. Free swing or automatic brake. Speed — 3 rpm.

ENGINE

GM 6V-53N diesel, 6 cyl ohv, 2 cycle, 197 hp at 2800 rpm, 318 cid (5.2), 3.875" bore x 4.5" stroke (98 mm x 114 mm), 21:1 compression ratio, 431 ft-lbs (59.6 mkg) max torque at 1500 rpm.

Electric starter, 12-volt 65 amp alternator, 225 amp hour battery, 20 hour rate (975 cca)

Air compressor, 12 cfm (5.7 l/sec)

Optional engine: Cummins V-555C215 diesel, 8 cyl ohv, 4 cycle, 207 hp at 2,800 rpm, 555 cid (9.1 L), 4-5/8" bore x 4-1/8" stroke (117 mm x 105 mm), 17:1 compression ratio, 425 ft-lbs (58.8 mkg) max torque at 1800 rpm. Electric starter, 12-volt 60 amp alternator, 225 amp hour battery, 20 hour rate (975 cca).

Air compressor, 13.2 cfm (6.2 l/sec).

Fuel capacity, either engine 130 gal (492 l)

TRANSMISSION

Six-speed with rear axle disconnect. Electric three speed range and directional shift with electric over air high low shift and rear axle disconnect.

Drive	Transmission Range	Gear Shift	Maximum Speed mph (km/hr)
4-wheel	Low	1st	1.6 (2.5)
4-wheel	Low	2nd	3.3 (5.3)
4-wheel	Low	3rd	8.8 (14)
2-wheel	High	1st	4.5 (7.2)
2-wheel	High	2nd	9.2 (14.8)
2-wheel	High	3rd	22.7 (36.5)

GRADEABILITY: NOTE: All performance data is based on standard machines, and may vary due to engine performance and optional equipment. Machine should be operated within a 30° slope limitation due to engine lubrication design.

AXLES

Ratio 22.4:1. Planetary steering. Front axle rigidly mounted to frame. Rear axle pinned for oscillation, automatic oscillation lockout, with manual override. Non-spin differential optional.

BRAKES

Four-wheel air service brakes. Drums 20.25" x 4" (514 mm x 102 mm). Spring-set emergency and parking brakes on all four wheels.

TIRES

26.5 x 25 26-ply, 22 25 rim

Optional:

29.5 x 25 22-ply, 25 x 25 rim.
Spare tire, tire inflation kit.

STEERING

Two independent systems. Front, hydrostatic controlled by Char-Lynn orbitrol unit. Rear, hydrostatic controlled by toggle switch on dash panel, with rear-wheel centering indicator light. Turning radius.

Front-wheel steering 38" (11.6m).

Four-wheel coordinated 21' 6" (6.6m).

OUTRIGGERS

Beam type, hydraulic powered. 24" (61 cm) diameter floats. 21' (6.4 m) spread center-to-center of jacks.

Optional: 30" (76 cm) floats.

WEIGHT — Lbs (kg)	Front Axle		Rear Axle	
	80' boom	105' boom	80' boom	105' boom
	77,500 (35,154)	79,700 (36,152)	40,200 (18,235)	43,500 (19,732)
			37,300 (16,919)	36,200 (16,420)

STANDARD EQUIPMENT

Dual headlights, tail lights, brake lights, back-up lights, turn signals, parking lights, front and rear fenders, tow loops, rear view mirrors, electronic boom angle indicator.

OPTIONAL EQUIPMENT

Jib: 25' (7.6 m) self-storing. Can only be erected to the end of the Side Fly.

Deluxe boom angle indicator. Electronic, with adjustable limit settings and audible warning.

Anti-Two block system. Electric-hydraulic, for boom. Side Fly, or jib. Stops boom lower, boom extend, winch up movements automatically, audible and visual warning signals in cab, manual override. Also available with audible and visual warning signals only, without automatic stop.

Working lights: On front of cab and on boom.

Rotating amber beacon. On top of cab.

Vandalism protection package: Padlocks for access and storage doors, fuel tank, Lexan windows.

Tow winch: Model PD-15, mounted on front of frame, controlled from cab. Line pull 15,000 lbs (680 kg).

Rooster sheave, 55-ton 5-sheave hook block, 15 ton single sheave hook block, headache ball with 5-ton swivel hook, headache ball with 3-ton swivel hook for auxiliary winch, drum rotation indicators for main and auxiliary winches, front and rear pintle hooks, electronic back-up alarm, cold-weather starting kit with extra battery, electric heating element for hydraulic reservoir.

BADGER CONSTRUCTION EQUIPMENT CO.

DIVISION OF BURRO-BADGER CORPORATION

Airport Industrial Park, P. O. Box 168

Winoona MN 55987

(507) 454-1563

12/79 10M-W&C
Printed in U.S.A.

