

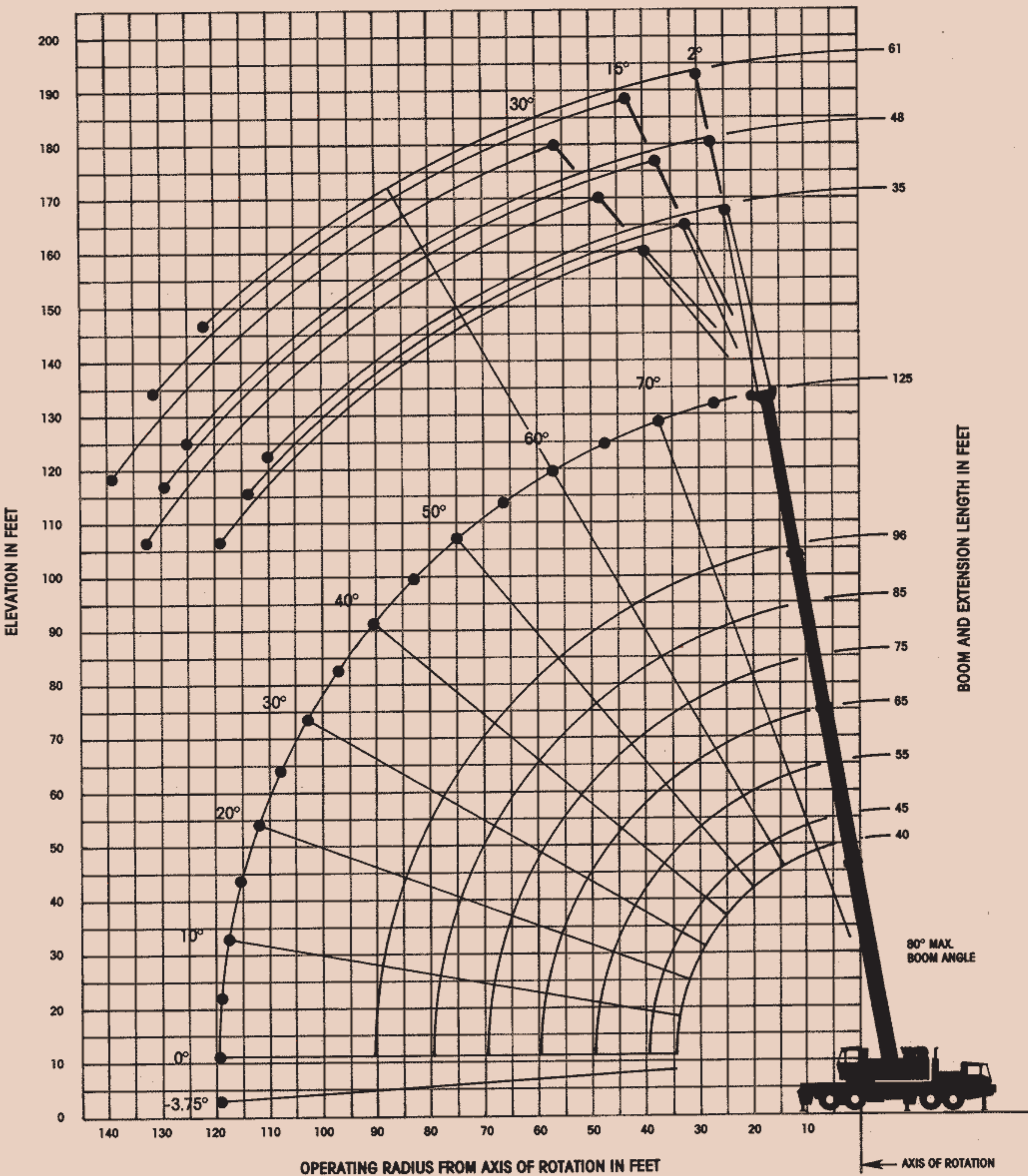

TMS760

85% Domestic/40 ft.-125 ft. Boom
Remote Aerial Power Pinned Fly

RANGE DIAGRAM (UNLADEN BOOM)



RATED LIFTING CAPACITIES IN POUNDS 40 FT. - 125 FT. BOOM (ON OUTRIGGERS - 360°)

Radius in Feet	Main Boom Length in Feet (Aerial Pinned Fly Retracted)							Aerial Pin. Fly Ext. & 96 ft.
	40	45	55	65	75	85	96	125
10	120,000 (72)	90,000 (74)	87,300 (77.5)	82,250 (79.5)				
12	100,000 (68.5)	85,400 (71.5)	83,000 (75)	77,400 (78)	60,550 (80)			
15	85,000 (63.5)	79,700 (67)	74,000 (72)	70,500 (75)	55,050 (78)	48,850 (79.5)	33,500 (81.5)	
20	64,800 (54.5)	64,400 (60)	58,700 (66)	55,250 (70.5)	47,250 (74)	41,600 (76)	33,500 (78.5)	21,000 (81.5)
25	51,500 (44.5)	51,400 (51.5)	47,800 (60)	44,100 (65.5)	41,400 (69.5)	36,100 (72.5)	33,000 (75)	21,000 (79)
30	41,750 (31)	41,750 (42)	39,900 (53.5)	36,300 (60.5)	34,250 (65.5)	31,300 (69)	28,150 (72)	19,050 (76.5)
35		33,800 (30)	33,800 (46)	31,100 (55)	28,650 (61)	26,500 (65)	23,800 (68.5)	16,800 (74.5)
40			24,000 (38)	24,000 (49)	24,000 (56.5)	22,800 (61)	20,350 (65.5)	15,000 (72)
45			19,000 (26.5)	19,000 (42.5)	19,000 (51.5)	19,000 (57)	17,600 (62)	13,500 (69.5)
50				15,500 (34.5)	15,500 (46)	15,500 (53)	15,350 (58.5)	12,250 (67)
60					10,200 (32.5)	10,200 (43)	10,200 (50.5)	10,300 (61.5)
70						7,000 (30.5)	7,000 (42)	8,300 (56)
80							4,500 (30.5)	6,560 (50)
90								5,140 (43)
100								3,000 (35.5)
110								2,000 (25)
Minimum boom angle (deg.) for indicated length (no load)							0	0
Maximum boom length (ft.) at 0 deg. boom angle (no load)							96	125

Note: Boom angles are in degrees.

A6-829-007084 & -007007A

CAPACITIES FOR 35 FT. - 61 FT. TELE. OFFSETTABLE EXTENSION (ON OUTRIGGERS - 360°)

Main Boom Angle (Deg.)	35 ft. LENGTH						48 ft. LENGTH						61 ft. LENGTH					
	2° OFFSET		15° OFFSET		30° OFFSET		2° OFFSET		15° OFFSET		30° OFFSET		2° OFFSET		15° OFFSET		30° OFFSET	
	Rad. Ref. ft.	Cap. lbs.	Rad. Ref. ft.	Cap. lbs.	Rad. Ref. ft.	Cap. lbs.	Rad. Ref. ft.	Cap. lbs.	Rad. Ref. ft.	Cap. lbs.	Rad. Ref. ft.	Cap. lbs.	Rad. Ref. ft.	Cap. lbs.	Rad. Ref. ft.	Cap. lbs.	Rad. Ref. ft.	Cap. lbs.
80	33.3	11,000	38.3	8,820	43.4	7,280	38.8	8,820	49.0	7,720	59.2	5,520	41.3	6,620	54.5	5,740	67.7	4,410
75	45.9	11,000	50.9	8,000	55.8	6,540	52.8	8,070	62.2	6,690	71.8	4,910	56.4	6,180	68.8	4,940	81.2	3,760
70	58.1	9,180	63.0	7,130	67.9	5,840	66.3	7,430	75.1	5,500	83.8	4,210	71.1	6,040	82.8	4,120	94.3	3,200
65	69.9	7,150	74.7	6,160	79.3	5,070	79.4	6,010	87.3	4,640	95.2	3,680	85.3	4,890	96.0	3,500	106.7	2,800
60	81.2	5,720	85.7	5,020	90.2	4,460	91.8	4,810	99.0	3,990	106.0	3,260	98.8	4,070	108.6	3,030	118.2	2,490
55	91.8	4,580	96.1	3,850	100.3	3,200	103.8	3,890	109.8	3,070	115.9	2,610	111.8	3,350	120.3	2,610	128.8	2,090
50	101.7	3,130	105.8	2,540	109.8	2,090	114.8	2,680	119.9	2,050	124.9	1,720	123.8	2,390	131.2	1,600	138.7	1,280
45	110.8	2,030	114.5	1,550	118.2	1,260	125.0	1,730	129.0	1,240	133.0	1,010						

*If two parts of line are used, the 2° offset capacity at 80° boom angle increases to 14,660 lbs. and at 75° boom angle increases to 12,200 lbs.

A6-829-007556A

NOTES FOR LIFTING CAPACITIES

1. All rated loads have been tested to and meet minimum requirements of SAE J1063 OCT80 - Cantilevered Boom Crane Structures - Method of Test, and do not exceed 85% of the tipping load on outriggers (75% of the tipping load on rubber) as determined by SAE J765 OCT80 Crane Stability Test Code.
2. This chart is intended as a guide only. The individual crane's load chart operating instructions and other instruction plates give details of the conditions under which the crane may be operated safely. ALL OF THESE INSTRUCTIONS MUST BE READ AND UNDERSTOOD PRIOR TO OPERATING THE CRANE.
3. Capacities given do not include the weight of hookblocks, slings, auxiliary lifting equipment and load handling devices. Their weights MUST be added to the load to be lifted. When more than minimum required reeving is used, the additional rope weight shall be considered part of the load.
4. Capacities appearing above the bold line are based on structural strength and tipping should not be relied upon as a capacity limitation.
5. All capacities are for crane on firm, level surface. It may be necessary to have structural supports under the outrigger floats or tires to spread the load to a larger bearing surface.
6. When either boom length or radius or both are between values listed, the smallest load shown at either the next larger radius or boom length shall be used.
7. For outrigger operation, ALL outriggers shall be fully extended with tires raised free of ground before raising the boom or lifting loads.
8. Tires shall be inflated to the recommended pressure before lifting on rubber.
9. Unless otherwise stated, capacities are with powered boom sections equally extended.

CAPACITIES FOR 35 FT. FIXED LENGTH EXTENSION (ON OUTRIGGERS - 360°)

Main Boom Angle (Deg.)	2° OFFSET		15° OFFSET		30° OFFSET	
	Rad. Ref. ft.	Cap. lbs.	Rad. Ref. ft.	Cap. lbs.	Rad. Ref. ft.	Cap. lbs.
80	33.3	*11,500	38.3	9,150	43.4	7,610
75	45.9	*11,500	50.9	8,330	55.8	6,870
70	58.1	9,510	63.0	7,460	67.9	6,170
65	69.9	7,480	74.7	6,490	79.3	5,400
60	81.2	6,050	85.7	5,350	90.2	4,790
55	91.8	5,000	96.1	4,360	100.3	3,700
50	101.7	3,650	105.8	3,060	109.8	2,600
45	110.8	2,560	114.5	2,070	118.2	1,770
40	119.1	1,720	122.4	1,320	125.8	1,120

*If two parts of line are used, the 2° offset capacity at 80° boom angle increases to 15,000 lbs. and at 75° boom angle increases to 12,500 lbs.

A6-829-007562A

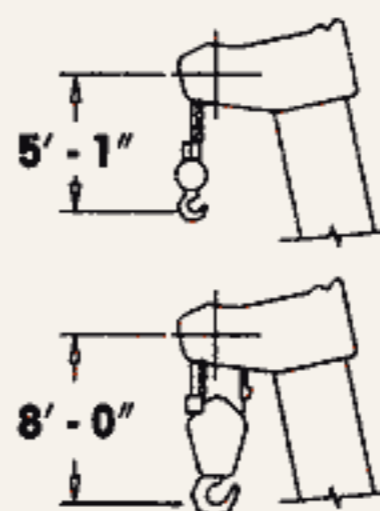

DIMENSIONS ARE FOR LARGEST GROVE FURNISHED HOOK BLOCK AND HEADACHE BALL, WITH ANTI-TWO BLOCK ACTIVATED.

WEIGHT REDUCTIONS FOR LOAD HANDLING DEVICES

35 FT. BOOM EXTENSION	
†Stowed -	556 lbs.
†Erected -	4,683 lbs.

35 FT. - 61 FT. TELE. BOOM EXTENSION	
†Stowed -	774 lbs.
†Erected (Retracted) -	6,438 lbs.
†Erected (Extended) -	8,658 lbs.

†Reduction of main boom capacities.

HOOKBLOCKS	
60 Ton, 5 Sheave	1,370 lbs.
40 Ton, 3 Sheave	640 lbs.
15 Ton, 1 Sheave	290 lbs.
10 Ton Headache Ball	560 lbs.
7-1/2 Ton Headache Ball	338 lbs.
5 Ton Headache Ball	172 lbs.
Auxiliary Boom Head	178 lbs.

Constant improvement and engineering progress makes it necessary that we reserve the right to make specification, equipment, and price changes without notice. Illustrations shown may include optional equipment and accessories and may not include all standard equipment.

North and South America, Far East, Australasia

GROVE MANUFACTURING COMPANY

Box 21 • Shady Grove • Pennsylvania 17256
(717) 597-8121 • telex: 842308 • fax: (717) 597-4062

Europe, Africa, Middle East, Indian Sub-continent

GROVE COLES LTD.

Telford Rd. • Bicester • Oxfordshire OX6 0TZ
(0869) 246800 • telex: 837447 • fax: 0869-246965

FORM NO.: LC-TMS760-Dom.-40'-125'

DATE: 189-10M
PRINTED IN U.S.A.



TMS760

85% Domestic/40 ft.-125 ft. Boom - Without Counterweight
Remote Aerial Power Pinned Fly

RANGE DIAGRAM (UNLADEN BOOM)

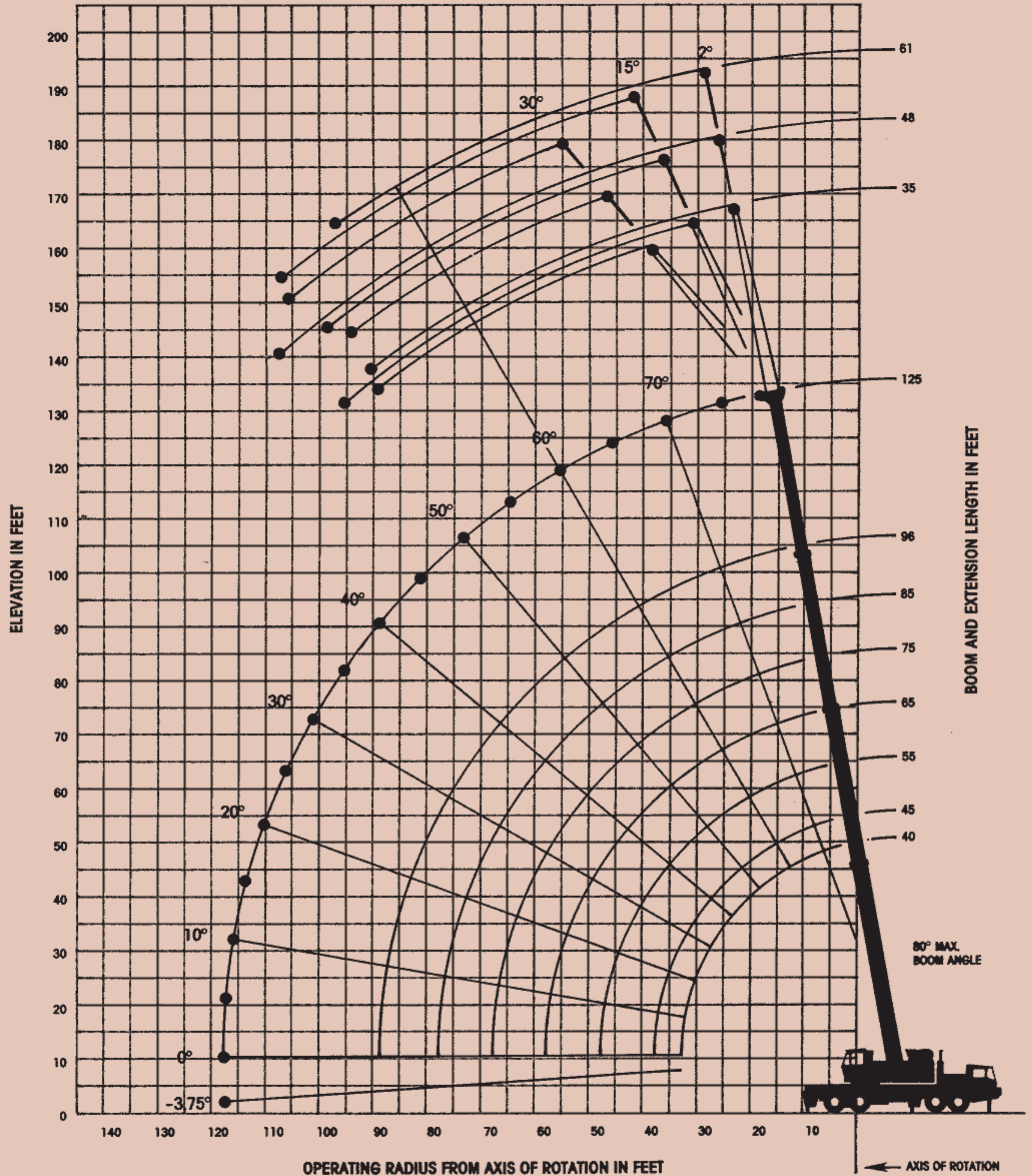

RATED LIFTING CAPACITIES IN POUNDS WITHOUT COUNTERWEIGHT 40 FT. - 125 FT. BOOM (ON OUTRIGGERS - 360°)

Radius in Feet	Main Boom Length in Feet (Aerial Pinned Fly Retracted)							Aerial Pin. Fly Ext. & 89 ft. 125
	40	45	55	65	75	85	96	
10	120,000 (72)	90,000 (74)	87,300 (77.5)	82,250 (79.5)				
12	98,300 (68.5)	85,400 (71.5)	83,000 (75)	77,400 (78)	60,550 (80)			
15	83,100 (63.5)	79,700 (67)	74,000 (72)	70,500 (75)	55,050 (78)	48,850 (79.5)	33,500 (81.5)	
20	60,550 (54.5)	60,550 (60)	58,700 (66)	55,250 (70.5)	47,250 (74)	41,600 (76)	33,500 (78.5)	21,000 (81.5)
25	46,000 (44.5)	46,000 (51.5)	46,000 (60)	44,100 (65.5)	41,400 (69.5)	36,100 (72.5)	33,000 (75)	21,000 (79)
30	33,300 (31)	33,300 (42)	33,300 (53.5)	33,300 (60.5)	33,300 (65.5)	31,300 (69)	28,150 (72)	19,050 (76.5)
35		24,200 (30)	24,200 (46)	24,200 (55)	24,200 (61)	24,200 (65)	23,800 (68.5)	16,800 (74.5)
40			18,050 (38)	18,050 (49)	18,050 (56.5)	18,050 (61)	18,050 (65.5)	15,000 (72)
45			13,700 (26.5)	13,700 (42.5)	13,700 (51.5)	13,700 (57)	13,700 (62)	13,500 (69.5)
50				10,500 (34.5)	10,500 (46)	10,500 (53)	10,500 (58.5)	12,250 (67)
60					6,100 (32.5)	6,100 (43)	6,100 (50.5)	8,300 (61.5)
70						3,220 (30.5)	3,220 (42)	5,340 (56)
80							1,180 (30.5)	3,250 (50)
90								1,690 (43)
Minimum boom angle (deg.) for indicated length (no load)							25	35
Maximum boom length (ft.) at 0 deg. boom angle (no load)							85	96

Note: Boom angles are in degrees.

A6-829-007792 & -007007A

CAPACITIES FOR 35 FT. - 61 FT. TELE. EXTENSION WITHOUT COUNTERWEIGHT (ON OUTRIGGERS 360°)

Main Boom Angle (Deg.)	35 ft. LENGTH						48 ft. LENGTH						61 ft. LENGTH					
	2° OFFSET		15° OFFSET		30° OFFSET		2° OFFSET		15° OFFSET		30° OFFSET		2° OFFSET		15° OFFSET		30° OFFSET	
	Rad. Ref. ft.	Cap. lbs.	Rad. Ref. ft.	Cap. lbs.	Rad. Ref. ft.	Cap. lbs.	Rad. Ref. ft.	Cap. lbs.	Rad. Ref. ft.	Cap. lbs.	Rad. Ref. ft.	Cap. lbs.	Rad. Ref. ft.	Cap. lbs.	Rad. Ref. ft.	Cap. lbs.	Rad. Ref. ft.	Cap. lbs.
80	33.3	11,000	38.3	8,820	43.4	7,280	38.8	8,820	49.0	7,720	59.2	5,520	41.3	6,620	54.5	5,740	67.7	4,410
75	45.9	11,000	50.9	8,000	55.8	6,540	52.8	8,070	62.2	6,690	71.8	4,910	56.4	6,180	68.8	4,940	81.2	3,760
70	58.1	9,180	63.0	7,130	67.9	5,840	66.3	7,430	75.1	5,500	83.8	3,920	71.1	6,040	82.8	4,120	94.3	3,050
65	69.9	6,140	74.7	4,930	79.3	3,910	79.4	4,760	87.3	3,310	95.2	2,140	85.3	4,510	96.0	2,810	106.7	1,490
60	81.2	3,550	85.7	2,730	90.2	2,000	91.9	2,600	99.0	1,660			98.9	2,420	108.6	1,290		
55	91.8	1,770	96.1	1,180			109.8	1,100										

*If two parts of line are used, the 2° offset capacity at 80° boom angle increases to 14,660 lbs. and at 75° boom angle increases to 12,200 lbs.

A6-829-007798A

CAPACITIES FOR 33 FT. FIXED LENGTH EXTENSION WITHOUT COUNTERWEIGHT (ON OUTRIGGERS - 360°)

Main Boom Angle (Deg.)	2° OFFSET		15° OFFSET		30° OFFSET	
	Rad. Ref. ft.	Cap. lbs.	Rad. Ref. ft.	Cap. lbs.	Rad. Ref. ft.	Cap. lbs.
80	33.3	11,500	38.3	9,150	43.4	7,610
75	45.9	11,500	50.9	8,330	55.8	6,870
70	58.1	9,510	63.0	7,460	67.9	6,170
65	69.9	6,660	74.7	5,420	79.3	4,380
60	81.2	4,070	85.7	3,230	90.2	2,480
55	91.8	2,300	96.1	1,680	100.3	1,140
50	101.7	1,020				

*If two parts of line are used, the 2° offset capacity at 80° boom angle increases to 15,000 lbs. and at 75° boom angle increases to 12,500 lbs. A6-829-007795A

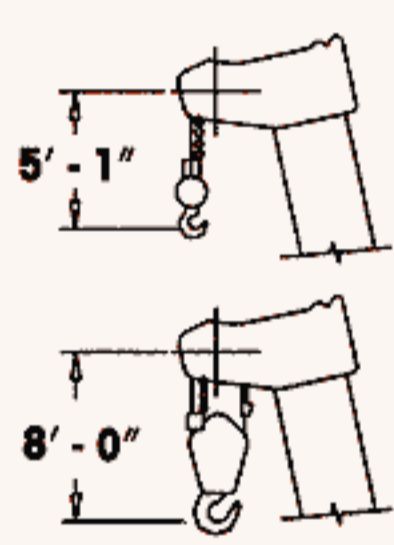

DIMENSIONS ARE FOR LARGEST GROVE FURNISHED HOOK BLOCK AND HEADACHE BALL, WITH ANTI-TWO BLOCK ACTIVATED.

WEIGHT REDUCTIONS FOR LOAD HANDLING DEVICES

35 FT. BOOM EXTENSION	
†Stowed -	556 lbs.
†Erected -	4,683 lbs.

35 FT. - 61 FT. TELE. BOOM EXTENSION	
†Stowed -	774 lbs.
†Erected (Retracted) -	6,438 lbs.
†Erected (Extended) -	8,658 lbs.

†Reduction of main boom capacities.

HOOKBLOCKS	
60 Ton, 5 Sheave	1,370 lbs.
40 Ton, 3 Sheave	640 lbs.
15 Ton, 1 Sheave	290 lbs.
10 Ton Headache Ball	560 lbs.
7-1/2 Ton Headache Ball	338 lbs.
5 Ton Headache Ball	172 lbs.
Auxiliary Boom Head	178 lbs.

NOTES FOR LIFTING CAPACITIES

1. All rated loads have been tested to and meet minimum requirements of SAE J1063 OCT80 - Cantilevered Boom Crane Structures - Method of Test, and do not exceed 85% of the tipping load on outriggers (75% of the tipping load on rubber) as determined by SAE J765 OCT80 Crane Stability Test Code.
2. This chart is intended as a guide only. The individual crane's load chart operating instructions and other instruction plates give details of the conditions under which the crane may be operated safely. ALL OF THESE INSTRUCTIONS MUST BE READ AND UNDERSTOOD PRIOR TO OPERATING THE CRANE.
3. Capacities given do not include the weight of hookblocks, slings, auxiliary lifting equipment and load handling devices. Their weights MUST be added to the load to be lifted. When more than minimum required reeving is used, the additional rope weight shall be considered part of the load.
4. Capacities appearing above the bold line are based on structural strength and tipping should not be relied upon as a capacity limitation.
5. All capacities are for crane on firm, level surface. It may be necessary to have structural supports under the outrigger floats or tires to spread the load to a larger bearing surface.
6. When either boom length or radius or both are between values listed, the smallest load shown at either the next larger radius or boom length shall be used.
7. For outrigger operation, ALL outriggers shall be fully extended with tires raised free of ground before raising the boom or lifting loads.
8. Tires shall be inflated to the recommended pressure before lifting on rubber.
9. Unless otherwise stated, capacities are with powered boom sections equally extended.

Constant improvement and engineering progress makes it necessary that we reserve the right to make specification, equipment, and price changes without notice. Illustrations shown may include optional equipment and accessories and may not include all standard equipment.

North and South America, Far East, Australasia

GROVE MANUFACTURING COMPANY

Box 21 ■ Shady Grove ■ Pennsylvania 17256
(717) 597-8121 ■ telex: 842308 ■ fax: (717) 597-4062

Europe, Africa, Middle East, Indian Sub-continent

GROVE COLES LTD.

Telford Rd. ■ Bicester ■ Oxfordshire OX6 0TZ
(0869) 246800 ■ telex: 837447 ■ fax: 0869-246965

FORM NO.: LC-TMS760-Dom.-40'-125'-W/O CWT

DATE: 189-10M
PRINTED IN U.S.A.