

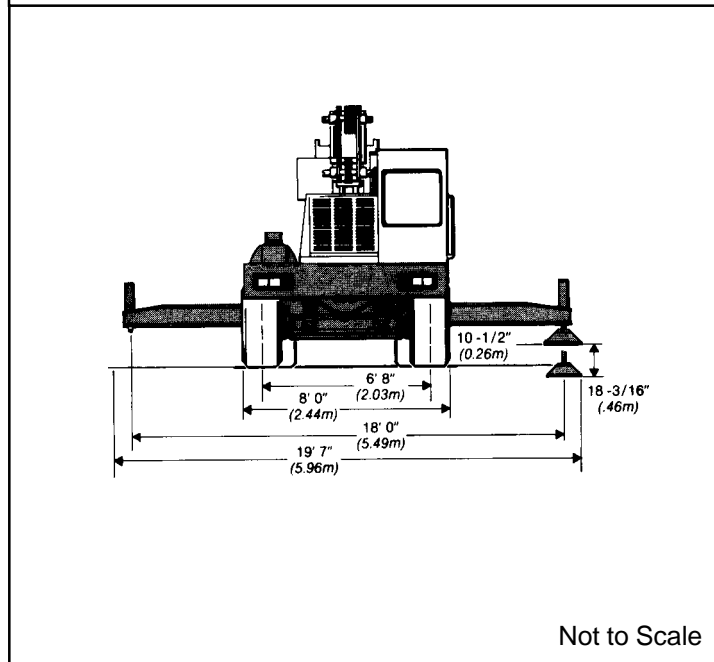
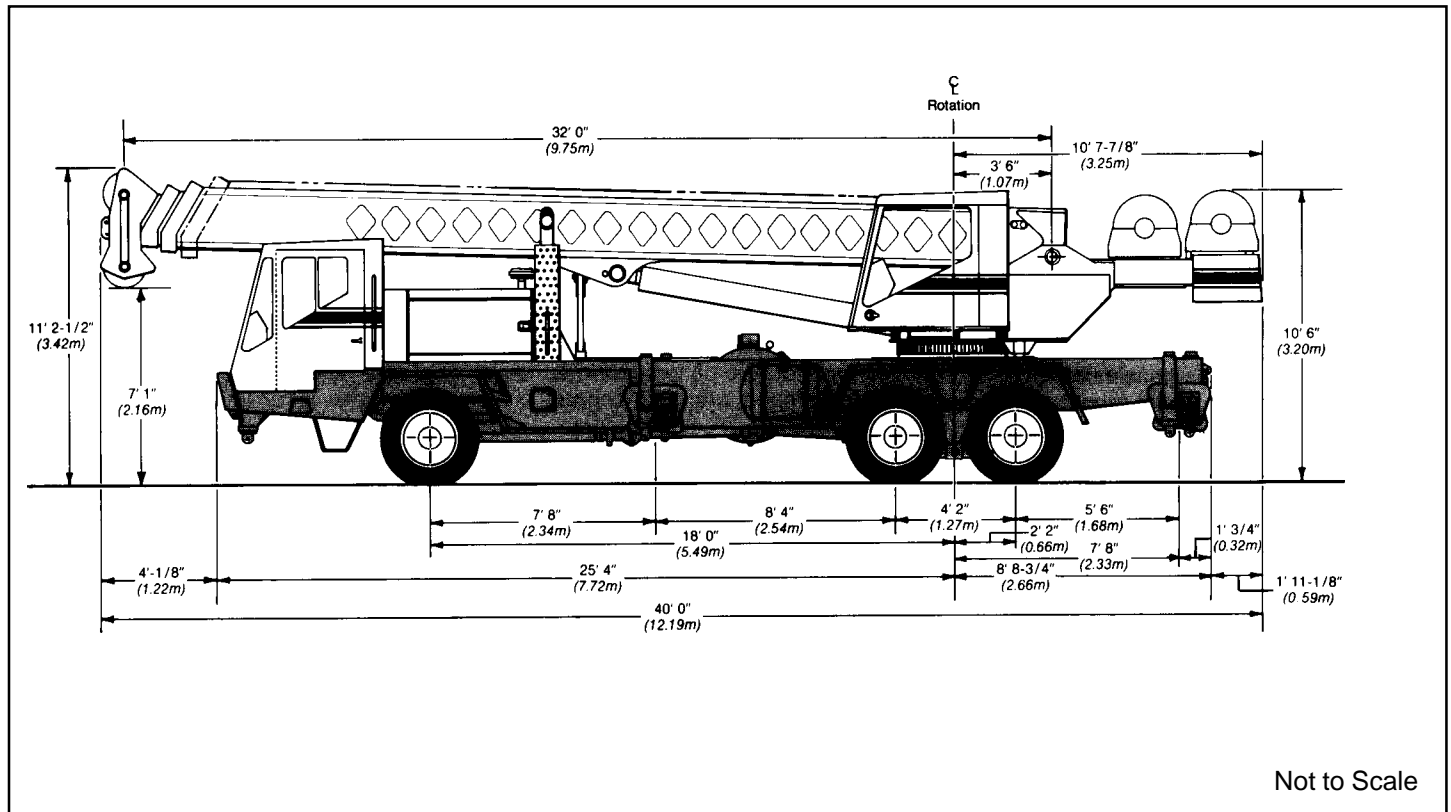

Specifications

Hydraulic Truck Crane

HTC-835

35-ton (31.77 metric ton)

General dimensions	feet	meters
Tailswing of counterweight	10'-11.5"	3.34
Ground clearance - Standard Tires	9.0"	.23
Ground clearance - Optional Tires	9.6"	.24
Turning radius C/L of tire - Std. tires	46' 11"	14.30
Turning radius - wall to wall (outside front bumper)	50' 7"	15.42



Upperstructure

■ Boom

Link-Belt patented design. 32' 0" - 80' 0" (9.75 m - 24.38 m) three-section boom with two power sections. Boom side plates have diamond shaped impressions for superior strength to weight ratio and are offset welded to carefully machined 100,000 p.s.i. (689.5 MPa) steel angle chords for maximum integrity and strength. Boom telescope sections are supported by wear shoes both vertically and horizontally. Anti-two block device, electronic boom length/angle indicator and function kickout.

Load Moment Indicator — Audio-visual warning system with anti-two block and function kickouts. Constant display of boom length and angle, tip height, radius of load, machine configuration, allowed load, actual load and % of allowed load. Presettable alarms for maximum and minimum boom angles, maximum tip height and maximum boom length.

Optional boom — 32' 0" - 101' 0" (9.75 m - 30.78 m) four-section boom includes base section, two power sections, and manual fourth section. Fourth section is power pinned by manually activating a cylinder locking system.

Boom head — Standard; three 14.5" (0.37 m) root diameter head sheaves with four 14.5" (0.37 m) root diameter head sheaves available to handle up to 8 parts of 5/8" (16 mm) wire rope. Two removable wire rope guards and rope dead end lugs are provided on each side of the boom head. Meets 24:1 ratio European safety code with 5/8" (16 mm) wire rope.

Auxiliary lifting sheave — *Optional*; Single 14.5" (0.37 m) root diameter head sheave with removable wire rope guards, mounted to boom. For use with one or two parts of line off the optional auxiliary winch. Does not affect erection of jib or use of main head sheaves for multiple reeving.

Boom elevation — One Link-Belt designed hydraulic boom hoist cylinder with holding valves. Hand or optional foot controls for boom elevation from -3° to 80°.

■ Fly

Optional — 29' 0" (8.84 m) stowable one-piece lattice type, with 2° offset.

■ Jib

Optional — 21' 0" (6.40 m) stowable A-frame. Attaches to fly only. Can be offset 5°, 17.5° and 30°.

■ Cab and Controls

Environmental cab; isolated from sound and vibration by rubber mounts. All tinted and tempered safety glass windows. For maximum visibility and ventilation, sliding right side and rear windows and swing up roof window supported with two gas cylinders. Slide-by-door opens to 3' 0" (0.91 m) width. Six-way adjustable operator's seat. Control levers for swing, boom telescope, winch and boom hoist, with foot control for swing brake and optional boom hoist. Outrigger controls, sight level bubble.

Cab instrumentation — Dash mounted gauges for hydraulic oil temperature, fuel, water temperature, and oil pressure.

■ Swing

Bi-directional hydraulic swing motor mounted to a planetary reducer for 360° continuous smooth swing at 2.05 r.p.m.

Swing brake — Standard; Foot operated, spring released disc brake mounted on the speed reducer.

Swing lock — Standard; 360° position pin-type controlled from the operator's cab. Two position house lock for travel and pick and carry modes.

Counterweight — Pinned to upperstructure frame.

■ Hydraulic System

Main pump — Three-section gear-type pump. Combined pump capacity of 133 gpm (503.4 lpm). Powered by carrier engine with pump disconnect. Pump disconnect is a jaw-type clutch engaged/disengaged from carrier cab. Maximum pressure at 2900 p.s.i. (200 Bars). Hydraulic oil cooler is standard.

Reservoir — Link-Belt, 110 gallon (416 L) capacity. Diffusers for deaeration.

Filtration — One six-micron filter located inside the hydraulic reservoir.

Control valves — Six separate control valves allow simultaneous operation of all crane functions.

■ Load Hoist System

Standard — Model 2M main winch with two-speed motor and automatic brake, power up/power down mode of operation. Bi-directional, gear-type hydraulic motor.

Optional — Model 2M auxiliary winch with two-speed motor and automatic brake, power up/power down mode of operation. Bi-directional, gear-type hydraulic motor.

Optional — Model 3M winch with two-speed motor and automatic brake; power up/power down mode and exclusive controlled true gravity free fall. Available on main or both winches.

Line pulls and speeds — Maximum line pull is 11,700 lbs. (5 307 kgs.) and maximum line speed is 414 f.p.m. (129.19 m/min) on 10-5/8" (0.27 m) root diameter smooth drum.

■ Additional Upperstructure Equipment - Optional

Boom hoist foot control, drum rotation indicators, propane heater, diesel heater, 25 ton (22.70 metric ton) or 35 ton (31.77 metric ton) hook block, roof window windshield wiper, 8-1/2 ton (7.72 metric ton) ball and swivel, flood lights, lifting lug package, hand throttle, windshield washer, amber rotating beacon, cab mounted spotlight, tachometer and engine monitoring system.



Carrier

■ Type

Link-Belt 8' 0" (2.44 m) wide, 216" (5.49 m) wheelbase.

Standard — 6 X 4 drive

Optional — 6 X 6 drive

Frame — All-welded high strength alloy steel plate construction with box-type design and integral 100,000 p.s.i. (689.5 MPa) steel outrigger boxes.

■ Outriggers

Standard — Power hydraulic, double box, single beam outriggers, front and rear. Vertical jack cylinders, each equipped with integral holding valve. Beams extend to 18' 0" (5.49 m) centerline-to-centerline and retract to within 8' 0" (2.44 m) overall width. Equipped with stowable, 19" (.48 m) square lightweight floats. Controls and sight level bubble located in upperstructure cab.

Front bumper outrigger— Standard; Front center vertical jack mounted under bumper with 19" (.48 m) square lightweight float. Provides 360° lifting capacities.

■ Axles

Front- Standard; Single axle, 81" (2.06 m) track.

Optional; Single drive axle, 79.75" (2.03 m) track.

Rear- Tandem axle, 71.77" (1.82 m) track. 6.14 to 1 ratio with interaxle differential.

■ Suspension

Front- Spring suspension.

Rear- Solid mount 50" (1.27 m) bogie beam.

■ Wheels

Front- Cast six spoke

Rear- Cast six spoke

■ Tires

Standard Front — 16.5 x 22.5 (16 PR) transport type tubeless.

Standard Rear — 10.0 x 20.0 (12 PR) transport type with tube.

Optional Rear — 10.0 X 20.0 (12 PR) or 11.0 x 20.0 (12-PR) lug type.

Optional Front — 425/65R22.5 XZY lug type radials.

Optional Rear — 11R20 XZY lug type radials.

■ Brakes

Full air on all wheels. Air dryer is standard.

Service

Front — Standard; 6 x 4 Cam-type 17-1/4" x 6" (.44 m x .10 m) shoe diameter.

Front — *Optional;* 6 x 6, 15" x 5" (.38 m x .13 m) shoe diameter.

Rear — Cam-type 16-1/2" X 7" (.42 m X .18 m) shoe diameter.

Parking & emergency — One spring set, air released chamber per rear axle end. Parking brake applied with valve mounted on carrier dash. Emergency brakes apply automatically when air pressure drops below 40 p.s.i. (2.76 Bars) in both systems.

■ Steering

Sheppard Steering, rack-and-pinion design. Provides wall-to-wall turning radius of 50' 7" (15.42 m).

Optional; Remote steering control system. Operated from upperstructure cab instrumentation includes toggle switch steering control, wheel position indicator, brake and transmission controls and parking brake control.

Clutch — Lipe-Rollway 14" (0.36 m) diameter, spring loaded, single plate dry disc.

Universals — Rockwell or spicer; easy service type.

■ Transmission

Standard — Fuller Roadranger RT-6613; 13 speeds forward, 3 reverse.

Optional — Allison MT-653DR; 5-speed automatic with lock-up converter.

■ Electrical System

Two 12-volt batteries; 1,950 cold cranking amps available, 105 amp alternator.

Lights — Four dual-beam sealed headlights, front and rear directional signals, stop and tail lights, four-way emergency flashers, back-up lights, front, rear and side clearance lights with integral reflectors, and license plate light.

■ Carrier Cab

One-man cab. Acoustical insulation with vinyl covering. Equipped with electric windshield wiper and washer, horn, four-way adjustable seat with seat belt, dome and dash lights, cigar lighter, ashtray, 22,400 BTU capacity heater, defroster, door and window locks, fire extinguisher, LH/RH rear view mirrors, tilt/telescoping steering wheel and sliding LH/RH and rear tinted windows.

Cab instrumentation — Standard; illuminated instrument panel with speedometer, odometer, tachometer, voltmeter, hourmeter, front and rear air pressure gauges, low air pressure light and warning buzzer, automotive-type ignition (common with upper), engine oil pressure gauge, water temperature gauge, fuel gauge, turn signal indicator, high beam light switch, adjustable defroster vents and circuit breakers.

■ Additional Equipment - Standard

Front and rear fenders, air dryer, back-up warning alarm, cab steps, access ladder to rear carrier deck with hand grab rails, front/rear tow loops, skid-resistant finish on carrier deck, mud flaps, and 120 volt 1000 watt engine coolant heater.

■ Additional Equipment - Optional

Propane engine block heater, ether injection starting package, spare tire and rim assemblies, towing shackles and engine monitoring system.

Travel Speeds and Gradeability ?



Link-Belt®

CONSTRUCTION EQUIPMENT

Travel speeds and gradeability ^①

Engine	Maximum Speed		Maximum Gradeability at Peak Torque	
	mph	km/h		
Cummins 6CTA8.3	47.3	76.12	Manual — 60.4%	Automatic — 70.9% (stall)

① Maximum speed based on full load r.p.m. Gradeability is based on peak torque of the engine and machine equipped with standard tires and G.V.W.

Engine specifications

Engine	Cummins 6CTA8.3
Cylinders -- cycle	6 -- 4
Bore	4.49" (.11 m)
Stroke	5.32" (.13 m)
Displacement	504.5 cu. in. (8 269 cm ³)
Gross engine power	210 hp @ 2,400 rpm
Peak torque	605 ft. lbs. (820 J)
Electric system	12 volt negative ground
Fuel capacity	60 gallons (227 L)
Alternator	105 amp
Crankcase capacity	25.2 qts. (23.8 L)
Air compressor	12 c.f.m. (.34 m ³ /min)
Coolant capacity	10.8 gal. (40.9 L)

Axle loads

Base machine with 32' 0" - 80' (9.75 m - 24.38 m) 3-section boom, 450' (137.16 m) of 5/8" (16 mm) wire rope, two-speed main winch, 6x4 carrier with Cummins 6CTA8.3 diesel engine, full fuel, front bumper outrigger, 16.5x22.5 front tires, 10x20 highway rear tires, full hydraulic oil, pontoons stored, 2,700 lbs. (1 224 kg) counterweight and Roadranger transmission	G.V.W. ^①		Upper facing front				Upper facing rear			
			Front axle		Rear axle		Front axle		Rear axle	
		lbs.	kg	lbs.	kg	lbs.	kg	lbs.	kg	lbs.
	51,343	23 289	16,634	7 545	34,709	15 744	9 596	4 353	41,747	18 936
32'-101' (9.75 m - 30.78 m) 4-section boom with 4,500 lb. (2 041 kg) counterweight	1,420	644	105	48	1,315	597	-2,919	-1 324	4,339	1 968
3M freefall rear winch with 450' (137.16 m) rope	41	19	-20	-9	61	28	20	9	21	10
Power up/down front winch with 350' (106.68 m) rope	516	234	-80	-36	596	270	80	36	436	198
(2) 3M freefall winches with 350' (106.68 m) rope on front and 450' (137.16 m) on rear	491	223	-44	-20	535	243	44	20	447	203
29' (8.84 m) lattice fly, stowed	1,080	490	629	285	451	205	-629	-285	1,709	775
21' (6.40 m) A-frame jib, stowed	970	440	490	222	480	218	-490	-222	1,460	662
Hookblock at bumper	650	295	903	410	-253	-115	903	410	-253	-115
Headache ball at bumper	325	147	481	218	-156	-71	481	218	-156	-71
Auxiliary lifting sheave	125	57	205	93	-80	-36	-205	-93	330	150
11 x 20 optional rear tires & rims	128	58	-	-	128	58	-	-	128	58
11R20 rear radials	400	181	-	-	400	181	-	-	400	181
6 x 6 drive	786	356	602	273	184	83	602	273	184	83

① Adjust gross vehicle weight & axle loading according to component weight. NOTE: All weights are ± 3%.

② When selecting a tire & drive combination, the front axle load with upper facing front should not exceed the limits in the table below.

Maximum FrontAxle Load Table

Drive	Tire	Maximum Axle Load @ 50 mph (80.45 km/h)*
6 x 4	16.5 x 22.5 H	19,700 lbs. (8 935 kg)
6 x 6	16.5 x 22.5 H	19,700 lbs. (8 935 kg)

* For speeds exceeding 50 mph (80.45 km/h) see Operator's Manual

Link-Belt Construction Equipment Company Lexington, Kentucky

A unit of Sumitomo Construction Machinery Co., Ltd.

©Link-Belt is a registered trademark. Copyright 1991. All rights reserved. We are constantly improving our products and therefore reserve the right to change designs and specifications.