

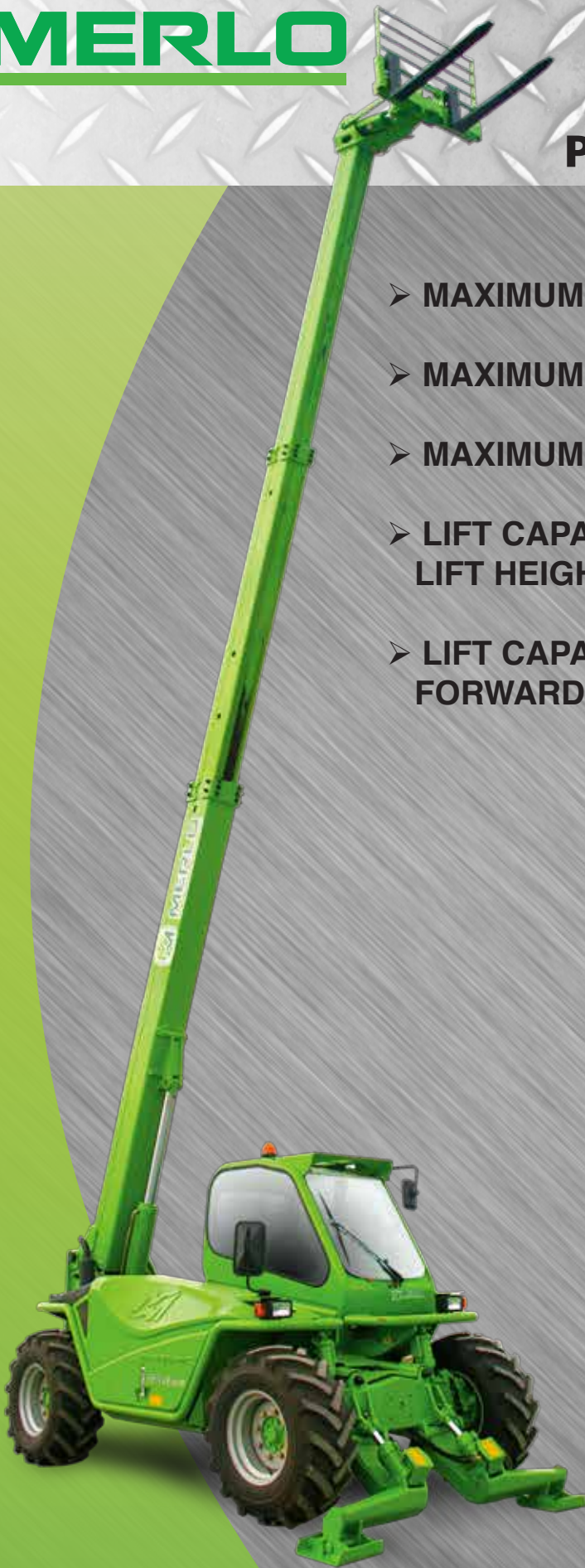

# MERLO

## P 38.13 EE STABILIZERS



- **MAXIMUM LOAD CAPACITY: 8,300 LBS**
- **MAXIMUM LIFT HEIGHT: 41' 3"**
- **MAXIMUM REACH: 28' 2"**
- **LIFT CAPACITY AT MAXIMUM LIFT HEIGHT: 7,700 LBS**
- **LIFT CAPACITY AT MAXIMUM FORWARD REACH: 1,600 LBS**

# SPECIFICATIONS: P 38.13 EE



Power / 4 Cylinder Turbo Diesel .....	Perkins / 101 HP
Transmission .....	2 Speed /Hydrostatic
Maximum Speed .....	21 MPH
Total Unladen Mass (with forks) .....	19,000 LBS
Boom Side Shift (Inches) .....	Standard / 13
Frame Leveling .....	Standard / ±10%
Load Sensing Hydraulic Pump (PSI - gal/min) ..	3,045-28.5
Fuel Capacity .....	40 Gallons
Hydraulic Oil Capacity .....	28 Gallons
Tires .....	405/70-20
Turning Radius .....	12'-8"
4 Wheel Drive / 3 Steering Modes .....	Standard
Hydraulic System .....	Load-Sensing
Independent Front Stabilizers .....	Standard

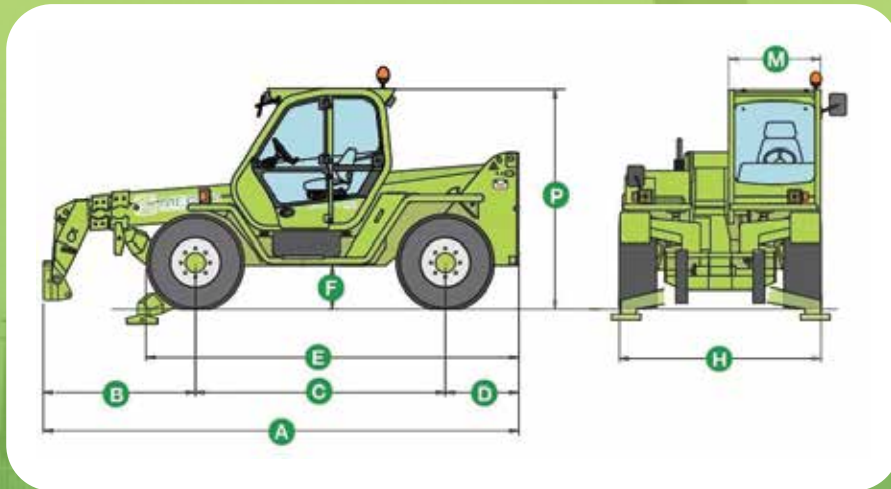
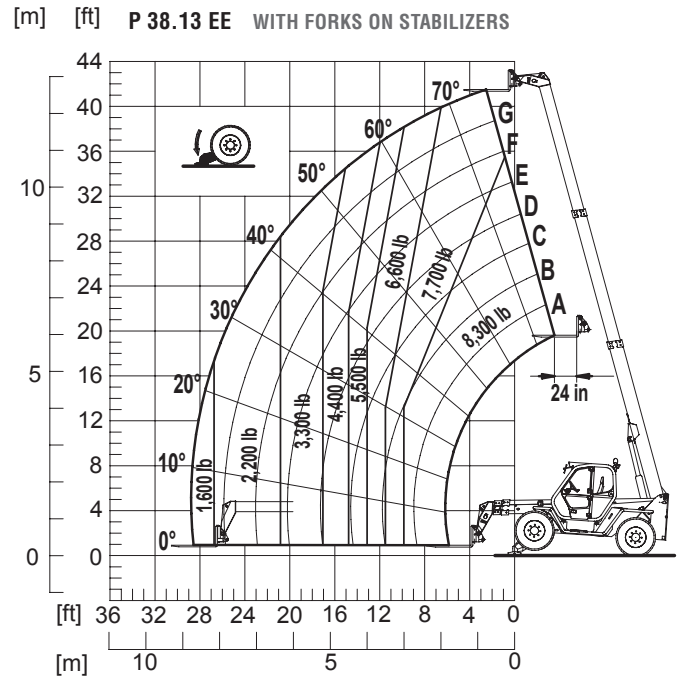

Dimensions (FT)					
A	17'-2"	D	2'-7"	H	7'-3"
B	5'-0"	E	13'-5"	M	3'-2"
C	9'-0"	F	1'-6"	P	8'-0"

DEALER INFORMATION: