



National Series 9000



**A heavy-duty telescoping crane from
America's truck-mounted hydraulic crane leader**

- Maximum Capacity: 46,000 Pounds (20.86 Metric Tons)
- Maximum Vertical Reach: 146 Feet (44.5 Meters)

Why Buy the National Series 900 Telescoping Crane?



Uncompromising Standards Unequaled Performance

National Crane Corporation, America's truck-mounted hydraulic crane leader, offers **these excellent reasons** to buy the Series 900, top of its class in the world of commercial truck-mounted cranes:

Extra-heavy lifting power

The National Series 900 has a rated capacity of 46,000 lb. (20.86 MT).

Extra-long reach

The Series 900 reaches vertically to 98 ft. (29.9 m) under hydraulic power. With the 48-foot (14.6-m) jib, Model 990 reaches to a height of 146 ft. (44.5 m).

Load Moment Indicator

The Series 900 is equipped with a Load Moment Indicator (LMI) that provides the operator with a continuous capacity reading as the crane makes a lift. When capacity is reached, an audio/visual alarm alerts the operator to take corrective action while the system deactivates functions that could contribute to an overload. (See p. 5.)

Proportional boom extension

National pioneered the proportional boom used with the Series 900. All four sections telescope proportionally, providing more efficient weight distribution, fast set up, extra-long reach and heavy-duty lifting power. (See p. 4.)

Operator-friendly controls

Dual controls are standard on the Series 900. Identical crane function controls are located on each side of the crane and in SAE-recommended orientation—same controls, same hand positioning. (See p. 6.)

High performance winch

A high performance planetary winch offers high line pull and fast standard speed, while requiring less horsepower and generating less heat. Its efficient orbit motor allows extra-smooth control, even at maximum load. (See p. 5.)

Mounts on standard trucks

The Series 900 mounts on standard, commercial tandem rear axle trucks, yet meets DOT and stability standards. Wide-span hydraulic outriggers, out-and-down rear stabilizers and the unitized mount take most of the stress, increasing truck life. (See p. 7.)

Heavy-duty triple pump hydraulics

A high pressure/high speed, balanced vane triple pump is standard on the Series 900, increasing productivity and ease of operation. This replaceable pump provides three individual hydraulic circuits for the independent operation of the winch, swing and crane functions. (See p. 7.)

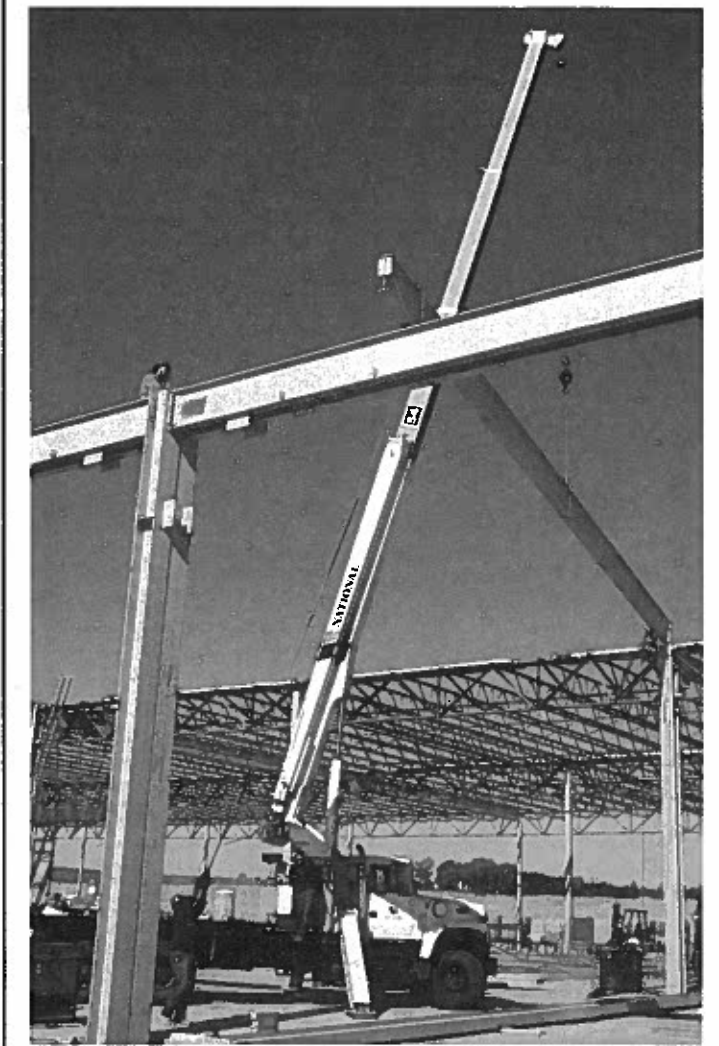

National Series 900

American-made quality, field-proven durability

- National Crane has manufactured cranes since 1963, with over 90 percent of them still on the job.
- Nationals consistently have the highest resale value in the industry.
- With an American-made National, you get more for each dollar you invest in a crane. Materials and components used are often of higher quality and greater value than those found in competitive products.
- Each crane undergoes numerous quality inspections at all levels of manufacture and assembly. No crane is shipped without a rigid final inspection.
- National Crane maintains a materials and components inspection program, ensuring that your National meets factory requirements.

Industry-leading test program

- Each crane prototype must pass the stringent test requirements of SAE J1063.
- National's test program subjects all crane prototypes to state-of-the-art stress coat and strain gauge testing, measuring metal deformation as slight as one-millionth of an inch (.025 microns).
- Prototypes undergo the toughest life cycle tests in the industry, receiving more punishment than most cranes encounter in a lifetime of rigorous use. Every structural component is cycle-tested, some through 60,000 cycles at full capacity. This requires thousands of working hours and takes months to complete.

Responsive service and parts support

- Each National crane is backed by strong after-sale and service support through a nationwide professional dealer network. A typical dealer has been associated with National for over a decade and knows our products from top to bottom.
- Authorized dealers stock parts to support the National cranes in their area. If your dealer cannot immediately supply a part, National maintains a back-up program and is committed to providing 24-hour shipping in over 90 percent of all break-down rush orders. That means your crane will be back on the job without needless delay.
- National also maintains a fully equipped service center at the plant to handle factory crane mounting, special modifications and repairs. However, most dealers can accommodate all but the most unusual or serious service needs.

Easier maintenance and less downtime

- When maintenance is necessary, you'll appreciate the way Nationals are designed and manufactured to simplify service and limit downtime.

The National warranty

- Our warranty covers your crane against defects in materials and workmanship for one year from date of shipment, subject to the conditions of the warranty. When you purchase a National, along with this protection and our long-standing commitment to quality, you have access to a nationwide dealer warranty service network.

Efficient boom design

- Computer-aided design allows higher lifting capacities by maximizing the weight efficiency of National booms.

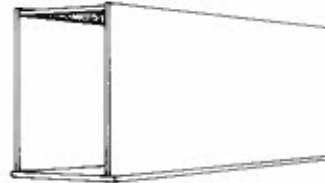

- Boom sections are fabricated from four high strength, low alloy steel members welded with perpendicular corners. This "box section" design uses thicker top and bottom plates to enhance boom strength, and thinner side plates to reduce boom weight and increase capacity.

- Welds are made with automatic, low hydrogen techniques to ensure strong, fatigue-resistant seams. Then they are ultrasonically tested to verify proper weld penetration.

Proportional boom extension

- Each boom extends and retracts proportionally during the telescoping operation. This four-section proportional (cable crowd) boom design—pioneered by National Crane—provides fast set up, more efficient boom weight distribution, minimum overlap for extra-long hydraulic reach with minimum retracted length, and higher capacities in normal working radii. Reduced boom

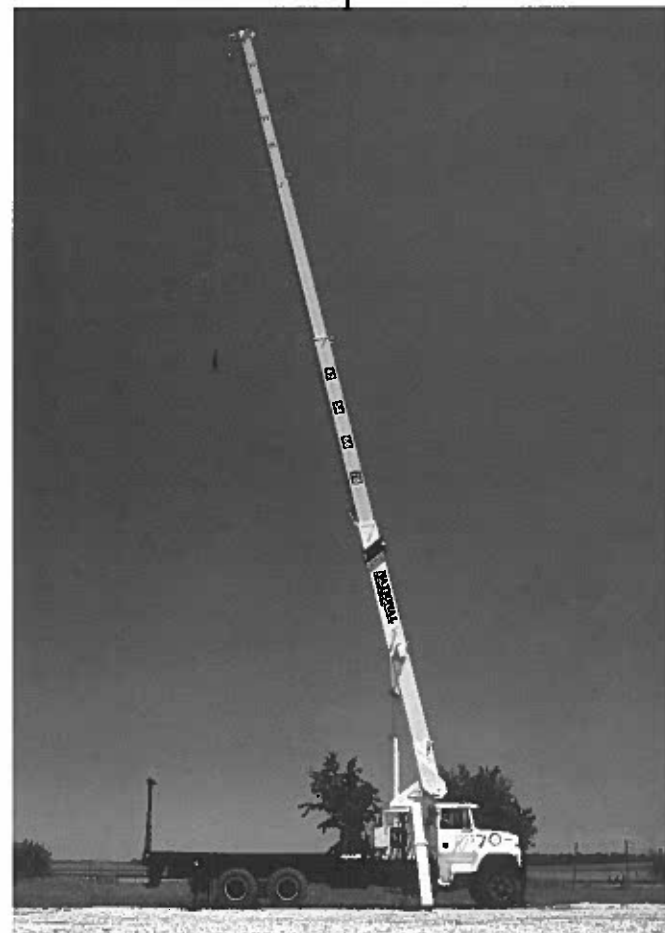

overhang (when stowed) also increases truck maneuverability.

- Dual high load carrying cables cycle the fourth stage boom. The use of cable (rather than chain) increases capacity and service life while reducing maintenance. Redundant cable sets are used for durability and reliability.
- All other boom sections are supported by one hydraulic extend cylinder, minimizing hydraulic maintenance. There are no fittings, tubes or hoses inside the booms, while access holes simplify wear pad and holding valve maintenance.

Easy Glide boom wear pads

- Extending or retracting, even at slow operating speeds, *Easy Glide* wear pads provide smooth, reduced friction boom movement. A unique technology pioneered by National, these self-lubricating wear pads deposit and maintain a long-lasting film on boom sections and pad surfaces.
- Although boom surfaces still require some routine greasing, *Easy Glide* pads are both easy to replace and efficient, reducing the conditions that cause noisy boom chatter, vibration, and accelerated wear.

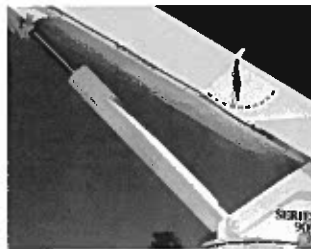

National's own cylinders

- National Crane controls the manufacture of its lift, outrigger and stabilizer

cylinders and seal packing, ensuring that standardized replacements fit properly.

- All load carrying cylinders are equipped with a direct mount holding valve for protection in the event of hose failure. Quiet, smooth and stable, these valves ensure precise load placement.

Stronger sheaves, multiple-part reeving

- The sheaves on the Series 900 consist of stronger, longer-wearing iron, not plastic. These resist flange chipping and wire rope core damage.
- The sheave case is rigged with two lower sheaves to allow (optional block) four-part reeving without attaching additional equipment at the boom tip.
- Multiple load blocks offer a range of increased lifting capacities while using the winch. Refer to the Winch Data section for line block options and speed/pull capabilities.



High performance planetary winch

- A high performance planetary gear drive winch increases efficiency, requires less horsepower and generates less heat. The efficient orbit motor, brake and counterbalance valves, and anti-friction roller bearings provide smooth, precise up and down control, even under maximum load.

- Payout and pickup of unloaded cable is increased by 60 percent over normal operating speeds when using National's special *Burst of Speed* winch circuitry, standard on the Series 900.
- The winch is filled with 9/16-inch (14-mm) die-drawn, rotation-resistant cable. Even under full load, spinning and twisting are minimized for more precise, tangle-free lifts and longer cable life. (General purpose, non-rotation-resistant cable is optional.)

National's operator aids

- National Crane's Load Moment Indicator (LMI) and Anti-Two-Block (ATB) systems share common components and work together as a dual-purpose protection system, standard on the Series 900.



Load Moment Indicator

- A state-of-the-art PAT DS150 LMI offers a console display of boom length and angle, load on hook and available capacity. These features provide the operator with a continuous capacity reading during lifts.
- Keyed system override is provided to address a boom position emergency. When overloads are relieved, the system automatically adjusts to allow use of all functions.

- As load capacity is approached, a caution light illuminates on the console. When capacity is reached, a red warning light and horn are activated while crane movement halts to prevent overload. The LMI then allows only the use of functions that will relieve the load condition (boom up, winch down, telescope in).



Anti-Two-Block system

- Two-blocking occurs when winch cable and attachment contact the underside of the boom or jib sheave case, due to winching up or extending the boom without paying out cable. This can cause crimping or over-tensioning damage to the cable.
- The ATB attachment senses the position of the winch cable end attachments with respect to the sheave case and, when necessary, shuts down functions that can cause two-blocking.

CAUTION

Do not operate crane booms, jib extensions, any accessories or loads within 10 feet (3 meters) of live power lines or other conductors of electricity • Jib and boom capacities shown are maximum for each section • Do not exceed capacities at reduced radii.

National Series 900

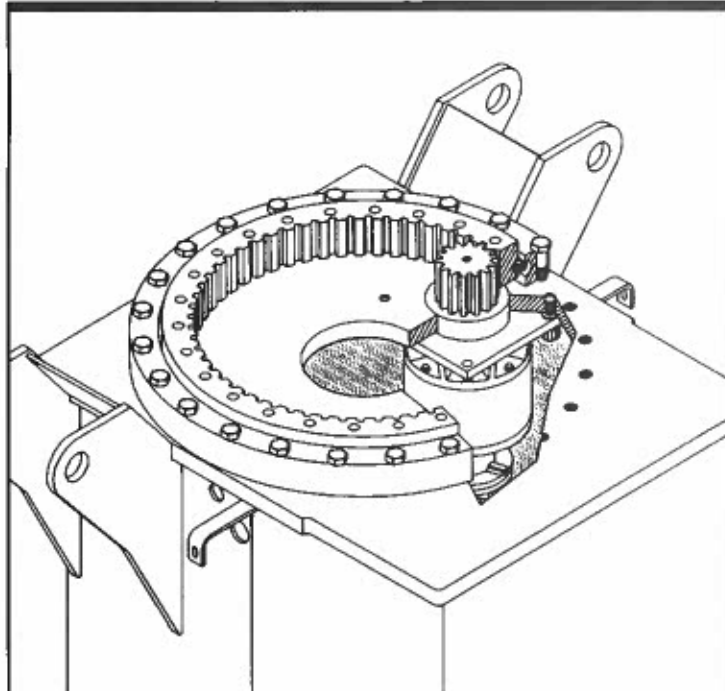

Positive planetary turret rotation

- Planetary rotation, with hydraulic release brake and slip-through, allows the gearbox to backdrive when excessive side load is applied to the rotation system. This reduces damaging shock loads on the gearbox and crane structure.
- The turret drive is designed with extra-heavy bearings below the drive pinion. The turntable bearing's full-circle bolt pattern ensures uniform loads, extending bearing life. The entire turret glides smoothly on a low-inertia ball bearing race.
- Gearbox and rotation bearing mounting surfaces are precision-machined after welding to ensure consistent tooth alignment, smooth rotation and low wear at all times.



- Rotation is 375-degree non-continuous. The rotation stop design gradually slows rotation of the boom, eliminating the sudden stop typical of non-continuous rotation.



Precise controls

- For greater efficiency and load visibility, the Series 900 is equipped with identical dual controls located on each side of the crane. Control functions are oriented according to SAE guidelines, while labeled knobs allow function identification.
- Extra-fine metering and low spool forces are coupled with adjustable levers to provide smooth, precise fingertip control of crane functions. Control rods are supported by smooth operating, easy-service bearings.
- Each console is equipped with a gauge that measures hydraulic system pressure and a level indicator that helps level the unit during set up. Each control station also includes a foot throttle, horn and stop switch. Extra-high back rests increase operator control and comfort.
- For maintenance, the control enclosure allows easy access to conveniently positioned control valves.

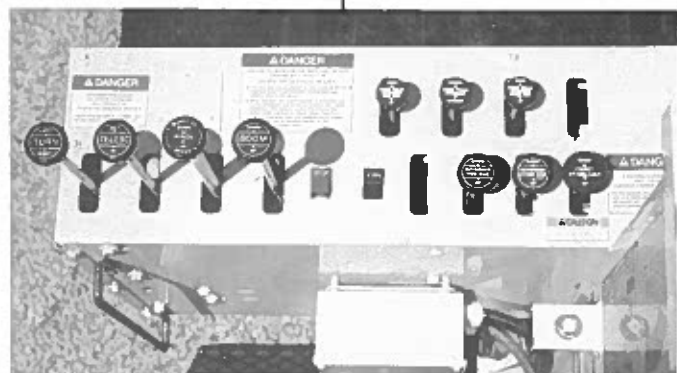

Heavy-duty hydraulic system

- A high pressure/high speed, vane-type triple pump system provides smooth, fast, simultaneous hydraulics. The winch is isolated from other crane functions for independent operation. Control valve spools are hard chrome-plated for long life and corrosion resistance. Contact the factory for continuous duty cycle applications.
- The extra-capacity 75-gallon (284-liter) hydraulic oil reservoir has a sight gauge, breather, suction strainer, clean-out and magnetic plug to reduce heat build-up and keep oil clean for longer life. The aluminized reservoir inhibits rust accumulation and, like the oil filters, is located externally for easy maintenance.



Wide stance

- The Series 900 is equipped with A-frame hydraulic outriggers spanning 21 feet (6.4 m) and out-and-down rear hydraulic stabilizers with a 14-foot (4.3-m) span. The outriggers retract smoothly without binding under load, while their

hydraulic power is sufficient to allow leveling of a fully loaded truck.



Lower truck requirements

- Nationals are engineered to lower your truck requirements, mounting on standard, heavy-duty commercial trucks, yet meeting DOT and stability standards with ease. Unitized mounting, out-and-down rear stabilizers and wide outrigger spans take the stress instead of the truck, making for a smaller investment in a longer lasting truck.

Unitized mounting

- Unitized mounting includes a one-piece subbase that supports the crane and bed for increased stability, while eliminating or reducing counterweight and truck reinforcing. Reinforcing is not required on trucks with 15.9 inch³ (260.6 cm³) section modulus frames of 110,000 psi (7590 bar) minimum yield steel. The crane and subbase ship separately, then solidly bolt together to form an integrated unit.

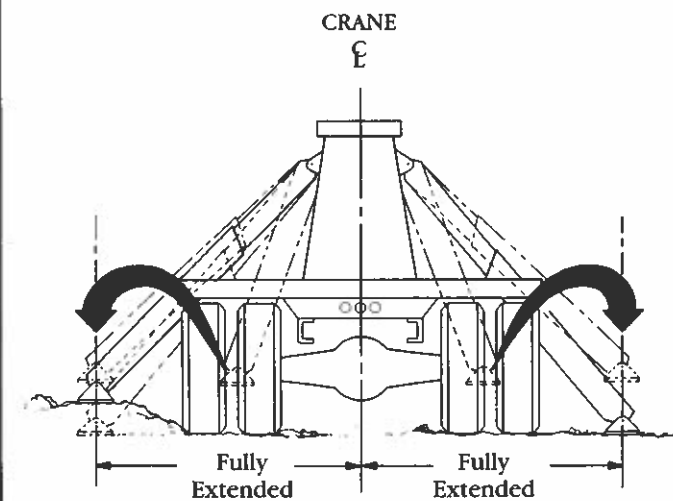

- Outriggers arch outward and down
- Feet don't "skid" into position
- Outriggers equidistant from center line
- Balanced stability and consistent span



Boom rests

- Cranes are tough when in use, but can be severely damaged during transport if not supported by a solid boom rest. All Nationals must be fitted with a boom rest to protect rotation gear from transport damage and spread crane load more evenly, reducing stress on the crane and truck frames. National boom rests fit various mounting configurations, reducing maintenance and adding years of crane life.

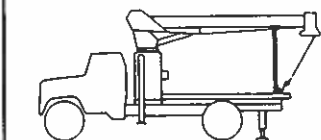

CAUTION

Do not operate crane booms, jib extensions, any accessories or loads within 10 feet (3 meters) of live power lines or other conductors of electricity • Jib and boom capacities shown are maximum for each section • Do not exceed capacities at reduced radii.

National Series 900 Booms and Jibs

Boom and Jib Combinations

The Series 900 is available in two basic models: the **Model 969**, equipped with a 69-ft. (21.0-m) three-section hydraulic boom; and the **Model 990**, equipped with a 90-ft. (27.4-m) four-section hydraulic boom.

Each model can also be equipped with one of two folding (side-stowing) jibs: the **9FJ15A**, a 15-ft. (4.6-m) single-section angling jib (for use with personnel carriers); and the **9FJ48M**, a 48-ft. (14.6-m) two-section jib with manual pull-out.

Model 969	27- to 69-ft. (8.2- to 21.0-m) boom 77-ft. (23.5-m) max. vertical reach	
	with 9FJ15A 15-ft. (4.6-m) jib* 92-ft. (28.0-m) max. vertical reach	
	with 9FJ48M 27- to 48-ft. (8.2- to 14.6-m) jib* 125-ft. (38.1-m) max. vertical reach	
Model 990	27- to 90-ft. (8.2- to 27.4-m) boom 98-ft. (29.9-m) max. vertical reach	
	with 9FJ15A 15-ft. (4.6-m) jib* 113-ft. (34.4-m) max. vertical reach	
	with 9FJ48M 27- to 48-ft. (8.2- to 14.6-m) jib* 146-ft. (44.5-m) max. vertical reach	

* Includes Anti-Two-Block (ATB) system

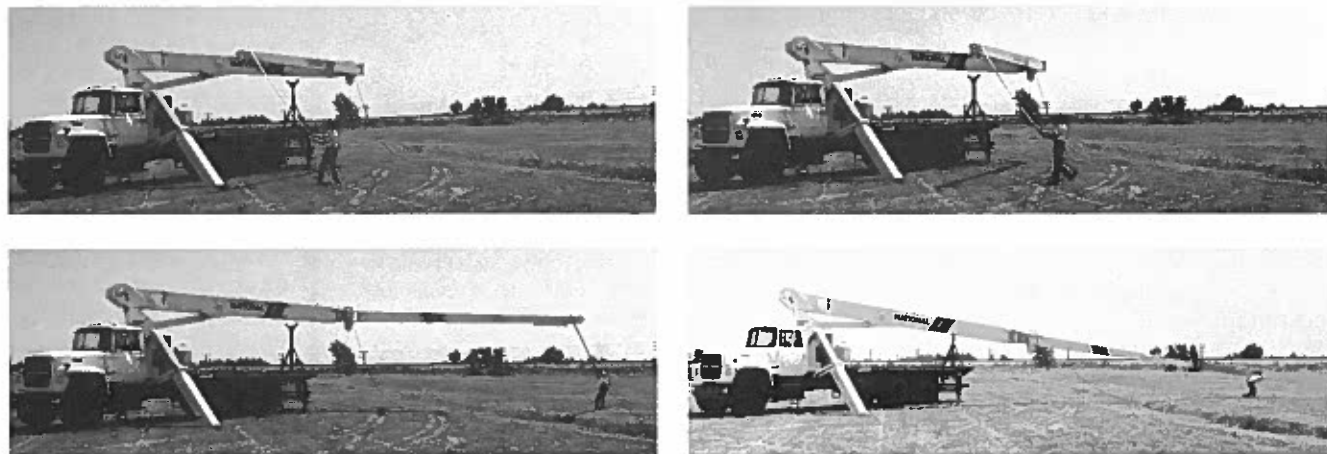

This photo sequence demonstrates how a National jib folds out into working position.

National Series 900 Winch Data

National Crane Series 900 Winch Data							
Cable Supplied	Average Breaking Strength	1 Part Line	2 Part Line	3 Part Line	4 Part Line	5 Part Line	6 Part Line
Standard 9/16-inch Diameter Rotation-Resistant	38,500 lb. (17,464 kg)						
Optional 9/16-inch Diameter General Purpose*	29,750 lb. (13,495 kg)						
Winch		Lift and Speed Data					
Standard Planetary Winch	Lift	7,700 lb. (3,493 kg)	15,400 lb. (6,985 kg)	23,100 lb. (10,478 kg)	30,800 lb. (13,971 kg)	38,500 lb. (17,464 kg)	46,000 lb. (20,865 kg)
	Speed	164 fpm (50 m/min)	82 fpm (25 m/min)	55 fpm (17 m/min)	41 fpm (12 m/min)	33 fpm (10 m/min)	27 fpm (8 m/min)
Using Burst of Speed	Lift	3,000 lb. (1,361 kg)	6,000 lb. (2,722 kg)	9,000 lb. (4,082 kg)	12,000 lb. (5,443 kg)	15,000 lb. (6,804 kg)	18,000 lb. (8,165 kg)
	Speed	265 fpm (81 m/min)	133 fpm (41 m/min)	88 fpm (27 m/min)	66 fpm (20 m/min)	53 fpm (16 m/min)	44 fpm (13 m/min)

* Non-rotation-resistant

All winch pulls and speeds are shown on the fourth layer. Winch line pulls would increase on the first, second and third layers. Winch line speeds would decrease on the first, second and third layers. Winch line pulls may be limited by winch capacity or the cable safety factor, shown below:

Winch	Bare Drum Pull	Allowable Drum Pull
With rotation-resistant cable	10,000 lb.	7,700 lb.
With general purpose cable	10,000 lb.	8,400 lb.

CAUTION

- Do not deadhead lineblock against boom tip when extending boom
- Keep at least three wraps of loadline on drum at all times
- Use only specified cable with this machine
- 3,000 lb. maximum capacity with Burst of Speed

CAUTION

Do not operate crane booms, jib extensions, any accessories or loads within 10 feet (3 meters) of live power lines or other conductors of electricity • Jib and boom capacities shown are maximum for each section • Do not exceed capacities at reduced radii.

National Series 900 Load Ratings Model 969 Without Jib

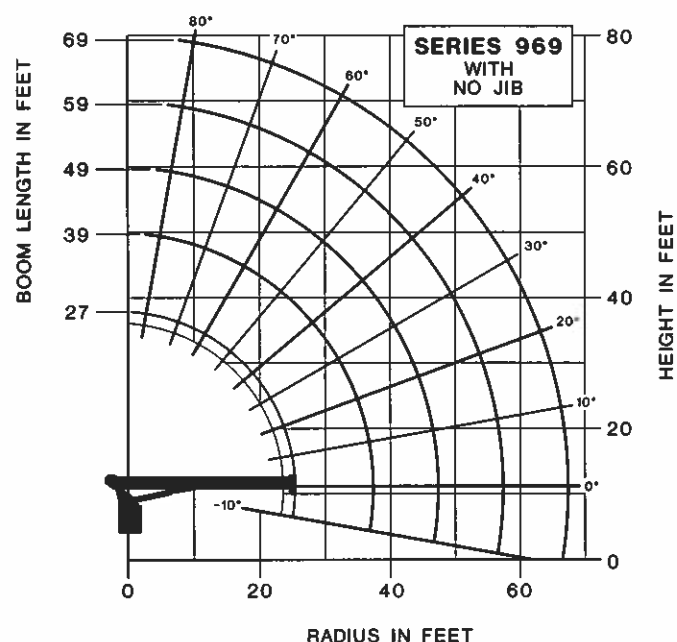

- Notes:**
1. Shaded portions of these charts are the structural strength ratings.
 2. Load ratings shown are maximum allowable loads under optimal conditions.
 3. Rated loads do not exceed 85 percent of the tipping load.

CAUTION

- These charts show maximum allowable loads with the crane properly leveled and mounted on a factory-recommended truck, and the outriggers properly extended on a firm, level surface.
- Always level the crane with the level indicator located on the crane frame.
- The operator must reduce loads to allow for factors such as wind, ground conditions, operating speeds and the effects of freely suspended loads.
- Weights of any accessories attached to the boom or load-line must be deducted from the load capacity charts.
- Crane overload may cause instability or structural collapse.

LMI OPERATING CODE SWITCH	
SWITCH POSITION (REF #17)	OPERATING MODE
01	MAIN BOOM - NO JIB STOWED
11	MAN BASKET ON MAIN BOOM

LOAD RATINGS											LOADLINE EQUIPMENT DEDUCT
LOAD RADIUS (FEET)	LOADED BOOM ANGLE	27FT BOOM (LBS)	LOADED BOOM ANGLE	39FT BOOM (LBS)	LOADED BOOM ANGLE	49FT BOOM (LBS)	LOADED BOOM ANGLE	59FT BOOM (LBS)	LOADED BOOM ANGLE	89FT BOOM (LBS)	
5	79	48,000									
8	72	34,000									
10	67	28,000									
12	62	24,100	71.5	22,000	76	20,800	79	19,500			
14	57	21,100	68.5	19,300	73.5	18,000	77	17,000	79.5	16,300	
16	51	18,700	65	17,100	71	16,000	75	15,000	77.5	14,300	
20	38	15,000	58.5	14,000	66	13,000	70.5	12,200	74	11,700	
25			49	11,300	59	10,500	65	9,900	69.5	9,500	
30			37	9,200	52	8,800	59.5	8,300	65	7,900	
35			21	7,100	43.5	7,500	53.5	7,100	60	6,700	
40					34	6,300	47	6,100	55	5,850	
45					19	4,800	39.5	5,300	49.5	5,100	
50							30.5	4,500	43.5	4,500	
55							17	3,400	36.5	3,900	
60									28.5	3,250	
65									16	2,450	
	0	7,200	0	4,200	0	2,800	0	1,950	0	1,250	

LOADLINE EQUIPMENT DEDUCT

DOWNHAUL WEIGHT = 150
 ONE SHEAVE BLOCK = 200
 TWO SHEAVE BLOCK = 355
 THREE SHEAVE BLOCK = 530

National Series 900 Load Ratings Model 969 With 48-Foot Jib

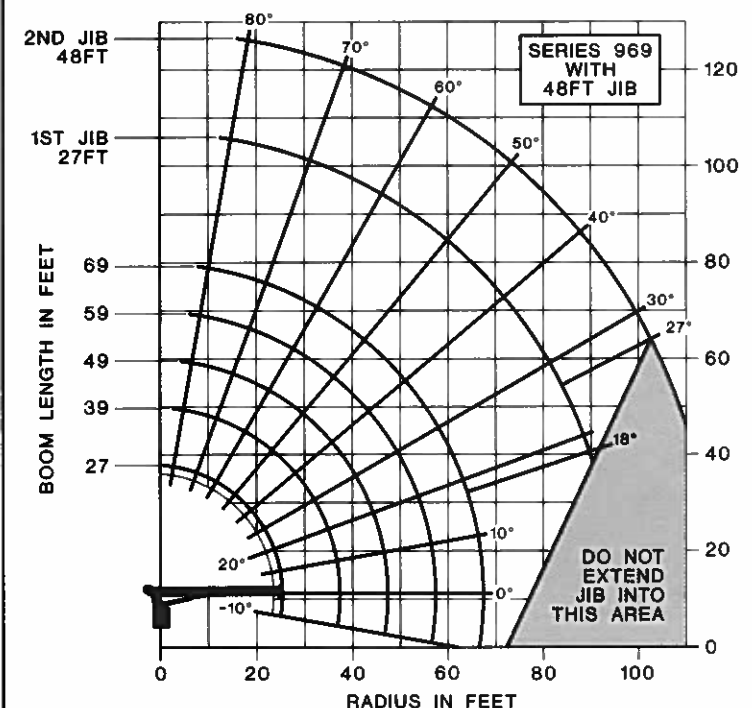

- Notes:**
1. Shaded portions of these charts are the structural strength ratings.
 2. Load ratings shown are maximum allowable loads under optimal conditions.
 3. Rated loads do not exceed 85 percent of the tipping load.

CAUTION

- These charts show maximum allowable loads with the crane properly leveled and mounted on a factory-recommended truck, and the outriggers properly extended on a firm, level surface.
- Always level the crane with the level indicator located on the crane frame.
- The operator must reduce loads to allow for factors such as wind, ground conditions, operating speeds and the effects of freely suspended loads.
- Weights of any accessories attached to the boom or load-line must be deducted from the load capacity charts.
- Crane overload may cause instability or structural collapse.

LMI OPERATING CODE SWITCH	
SWITCH POSITION (REF #17)	OPERATING MODE
01	MAIN BOOM - NO JIB STOWED
02	MAIN BOOM - JIB STOWED
03	27 FT TELE JIB
04	48 FT TELE JIB
11	MAN BASKET ON MAIN BOOM
12	MAN BASKET ON 27 FT TELE JIB
13	MAN BASKET ON 48 FT TELE JIB

LOAD RATINGS															
LOAD RADIUS (FEET)	LOADED BOOM ANGLE	27FT BOOM (LBS)	LOADED BOOM ANGLE	39FT BOOM (LBS)	LOADED BOOM ANGLE	49FT BOOM (LBS)	LOADED BOOM ANGLE	59FT BOOM (LBS)	LOADED BOOM ANGLE	89FT BOOM (LBS)	LOAD RADIUS (FEET)	LOADED BOOM ANGLE	27FT JIB (LBS)	LOADED BOOM ANGLE	48FT JIB (LBS)
5	79	48,000									25	75.5	7,800	79	4,400
8	72	33,300									30	72.5	6,800	76.5	4,000
10	67	27,300									35	69.5	5,700	74	3,700
12	62	23,400	71.5	21,550	76	20,450	79	19,200			40	66	4,900	71.5	3,400
14	57	20,400	68.5	18,850	73.5	17,850	77	16,700	79.5	16,050	45	62.5	4,200	69	3,100
16	51	18,000	65	16,850	71	16,850	75	14,700	77.5	14,050	50	59	3,650	66.5	2,900
20	38	14,300	58.5	13,550	66	12,650	70.5	11,900	74	11,450	55	55.5	3,200	64	2,700
25			49	10,850	59	10,150	65	9,800	69.5	9,250	60	51.5	2,800	61	2,500
30			37	8,750	52	8,350	59.5	8,000	65	7,650	65	47.5	2,450	58	2,300
35			21	6,650	43.5	7,150	53.5	6,800	60	6,450	70	43.5	2,100	55	2,100
40					34	5,850	47	5,800	55	5,600	75	38.5	1,800	52	1,900
45					19	4,450	39.5	5,000	49.5	4,850	80	33.5	1,500	49	1,700
50							30.5	4,200	43.5	4,250	85	27	1,200	45	1,500
55							17	3,100	36.5	3,650	90	18	750	41	1,300
60									28.5	3,000	95			37	1,100
65									16	2,200	100			32	900
	0	6,500	0	3,750	0	2,450	0	1,650	0	1,000	105			27	700

LOADLINE EQUIPMENT DEDUCT

DOWNHAUL WEIGHT = 150
 ONE SHEAVE BLOCK = 200
 TWO SHEAVE BLOCK = 355
 THREE SHEAVE BLOCK = 530

National Series 900 Load Ratings Model 969 With 15-Foot Angling Jib

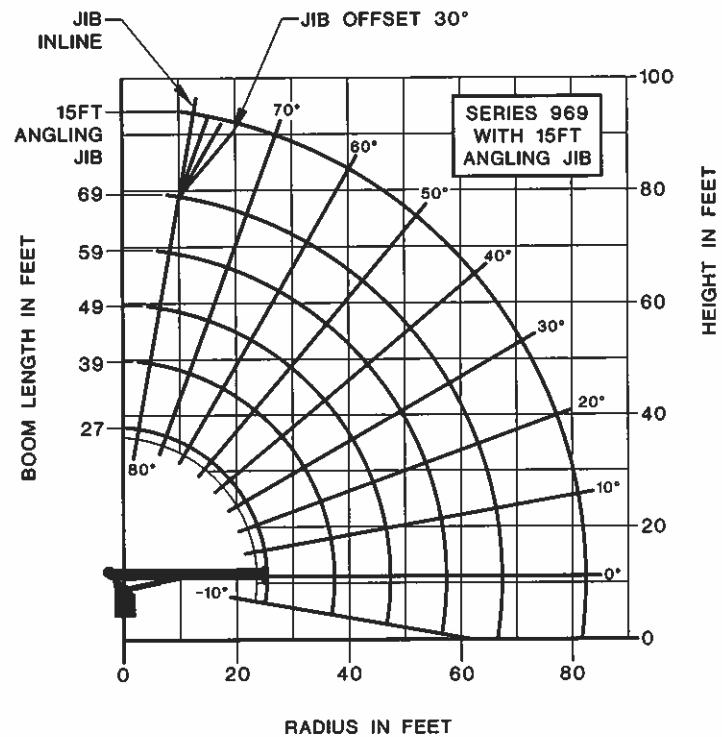

- Notes:**
1. Shaded portions of these charts are the structural strength ratings.
 2. Load ratings shown are maximum allowable loads under optimal conditions.
 3. Rated loads do not exceed 85 percent of the tipping load.

CAUTION

- These charts show maximum allowable loads with the crane properly leveled and mounted on a factory-recommended truck, and the outriggers properly extended on a firm, level surface.
- Always level the crane with the level indicator located on the crane frame.
- The operator must reduce loads to allow for factors such as wind, ground conditions, operating speeds and the effects of freely suspended loads.
- Weights of any accessories attached to the boom or load-line must be deducted from the load capacity charts.
- Crane overload may cause instability or structural collapse.

LMI OPERATING CODE SWITCH	
SWITCH POSITION (REF #17)	OPERATING MODE
01	MAIN BOOM - NO JIB STOWED
02	MAIN BOOM - JIB STOWED
06	15FT ANGLING JIB 0° OFFSET
07	15FT ANGLING JIB 10° OFFSET
08	15FT ANGLING JIB 20° OFFSET
09	15FT ANGLING JIB 30° OFFSET
11	MAN BASKET ON MAIN BOOM
13	MAN BASKET ON 15FT ANGLING JIB 0° OFFSET
14	MAN BASKET ON 15FT ANGLING JIB 10° OFFSET
15	MAN BASKET ON 15FT ANGLING JIB 20° OFFSET
16	MAN BASKET ON 15FT ANGLING JIB 30° OFFSET

LOAD RATINGS										JIB LOAD RATINGS (SAME CAPACITY FOR ANY OFFSET ANGLE)		
LOAD RADIUS (FEET)	LOADED BOOM ANGLE	27FT BOOM (LBS)	39FT BOOM (LBS)	49FT BOOM (LBS)	59FT BOOM (LBS)	69FT BOOM (LBS)	79FT BOOM (LBS)	89FT BOOM (LBS)	99FT BOOM (LBS)	LOAD RADIUS (FEET)	LOADED BOOM ANGLE	CAPACITY (LBS)
5	79	48,000								20	77	6,000*
8	72	33,400								25	72.5	3,650
10	67	27,400								30	70	3,000
12	62	23,500	71.5	21,800	76	20,600	79	19,250		35	65	2,500
14	57	20,500	68.5	18,900	73.5	17,700	77	16,750	79.5	40	62	2,200
16	51	18,100	65	16,700	71	15,700	75	14,750	77.5	45	58	2,000
20	38	14,400	58.5	13,800	66	12,700	70.5	11,950	74	50	53	1,500
25			49	10,800	59	10,200	65	9,850	69.5	55	49	1,300
30			37	8,800	52	8,800	59.5	8,050	65	60	45	900
35			21	6,700	43.5	7,200	53.5	6,850	60	65	39	600
40					34	6,000	47	5,860	55	70	34	460
45					19	4,500	39.5	5,050	49.5			
50							30.5	4,260	43.5			
55							17	3,150	36.5			
60									28.5			
65									16			
0		6,500	0	3,750	0	2,450	0	1,650	0			
ADD TO CAPACITIES WHEN NO JIB STOWED (LBS)												
		600		400		300		250				

LOADLINE EQUIPMENT DEDUCT
 DOWNHAUL WEIGHT = 150
 ONE SHEAVE BLOCK = 200
 TWO SHEAVE BLOCK = 355
 THREE SHEAVE BLOCK = 530

National Series 900 Load Ratings Model 990 Without Jib

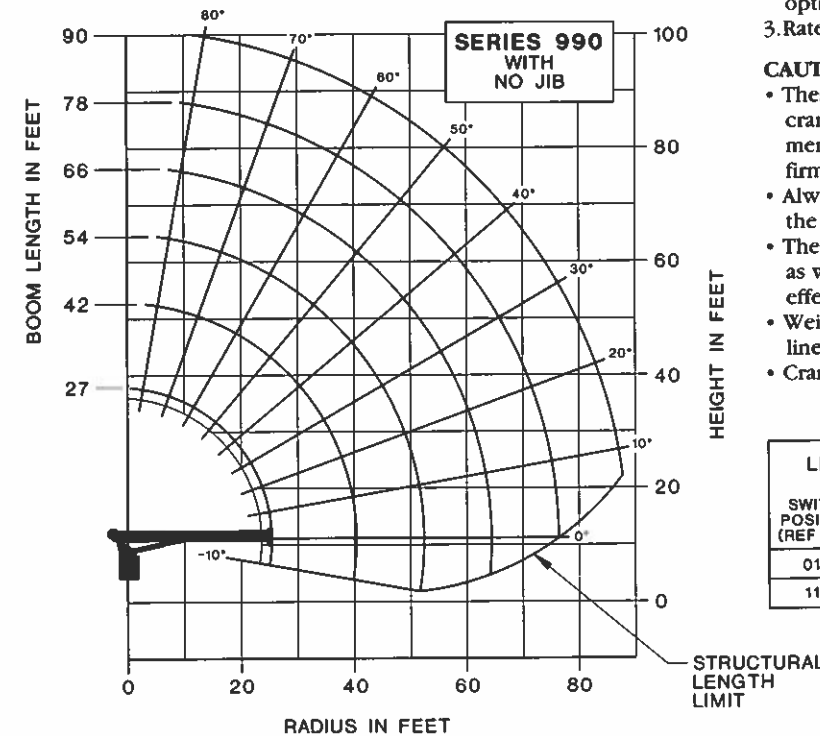

- Notes:**
1. Shaded portions of these charts are the structural strength ratings.
 2. Load ratings shown are maximum allowable loads under optimal conditions.
 3. Rated loads do not exceed 85 percent of the tipping load.

CAUTION

- These charts show maximum allowable loads with the crane properly leveled and mounted on a factory-recommended truck, and the outriggers properly extended on a firm, level surface.
- Always level the crane with the level indicator located on the crane frame.
- The operator must reduce loads to allow for factors such as wind, ground conditions, operating speeds and the effects of freely suspended loads.
- Weights of any accessories attached to the boom or load-line must be deducted from the load capacity charts.
- Crane overload may cause instability or structural collapse.

LMI OPERATING CODE SWITCH	
SWITCH POSITION (REF #17)	OPERATING MODE
01	MAIN BOOM - NO JIB STOWED
11	MAN BASKET ON MAIN BOOM

LOAD RATINGS											LOADLINE EQUIPMENT DEDUCT			
LOAD RADIUS (FEET)	LOADED BOOM ANGLE	27FT BOOM (LBS)	LOADED BOOM ANGLE	42FT BOOM (LBS)	LOADED BOOM ANGLE	54FT BOOM (LBS)	LOADED BOOM ANGLE	66FT BOOM (LBS)	LOADED BOOM ANGLE	78FT BOOM (LBS)	LOADED BOOM ANGLE	90FT BOOM (LBS)		
5	79	48,000												
8	72	33,000												
10	67	27,400	76.5	23,900	80	22,300								
12	62	23,500	73.5	20,900	77.5	19,100								
14	57	20,500	70.5	18,100	75.5	16,700	79	15,400						
16	51	18,100	67.5	16,100	73.5	14,800	77	13,500	79.5	12,800				
20	37	14,500	61	13,100	68.5	12,000	73	11,000	76.5	10,200	79	9,800		
25			52.5	10,500	62.5	9,700	68.5	8,900	72.5	8,200	75.5	7,700		
30			43	8,650	56	8,100	63.5	7,300	68.5	6,700	72	6,200		
35			30	6,950	49	6,700	58.5	6,200	64.5	5,850	68.5	5,200		
40					41	5,700	53	5,300	60	4,860	65	4,500		
45					31.5	4,700	47	4,600	55.5	4,200	61.5	3,900		
50					17	3,400	40.5	3,850	51	3,700	57.5	3,350		
55							32.5	3,200	45.5	3,200	53.5	2,900		
60							22	2,450	40	2,700	49	2,600		
65									33	2,250	44.5	2,150		
70									25	1,750	39.5	1,800		
75									11	900	34	1,450		
80											27	1,100		
85											17	600		
0		7,200	0	3,400	0	1,900	0	900						

LOADLINE EQUIPMENT DEDUCT
 DOWNHAUL WEIGHT = 150
 ONE SHEAVE BLOCK = 200
 TWO SHEAVE BLOCK = 355
 THREE SHEAVE BLOCK = 530

National Series 900 Load Ratings Model 990 With 48-Foot Jib

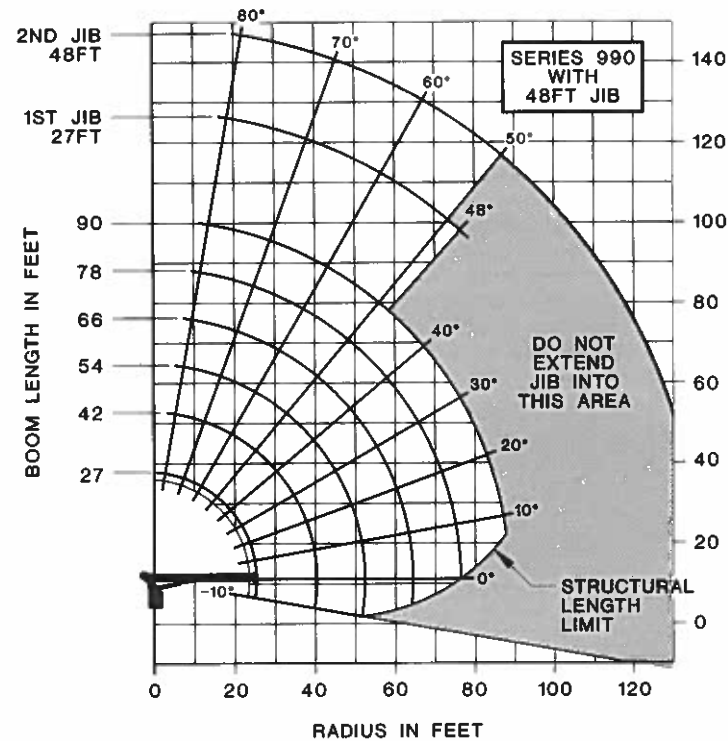

- Notes:**
1. Shaded portions of these charts are the structural strength ratings.
 2. Load ratings shown are maximum allowable loads under optimal conditions.
 3. Rated loads do not exceed 85 percent of the tipping load.

- CAUTION**
- These charts show maximum allowable loads with the crane properly leveled and mounted on a factory-recommended truck, and the outriggers properly extended on a firm, level surface.
 - Always level the crane with the level indicator located on the crane frame.
 - The operator must reduce loads to allow for factors such as wind, ground conditions, operating speeds and the effects of freely suspended loads.
 - Weights of any accessories attached to the boom or load-line must be deducted from the load capacity charts.
 - Crane overload may cause instability or structural collapse.

LMI OPERATING CODE SWITCH	
SWITCH POSITION (REF #17)	OPERATING MODE
01	MAIN BOOM - NO JIB STOWED
02	MAIN BOOM - JIB STOWED
03	27 FT TELE JIB
04	48 FT TELE JIB
11	MAN BASKET ON MAIN BOOM
12	MAN BASKET ON 27 FT TELE JIB
13	MAN BASKET ON 48 FT TELE JIB

LOAD RATINGS												
LOAD RADIUS (FEET)	LOADED BOOM ANGLE	27FT BOOM (LBS)	LOADED BOOM ANGLE	42FT BOOM (LBS)	LOADED BOOM ANGLE	54FT BOOM (LBS)	LOADED BOOM ANGLE	66FT BOOM (LBS)	LOADED BOOM ANGLE	78FT BOOM (LBS)	LOADED BOOM ANGLE	90FT BOOM (LBS)
5	79	48,000										
8	72	32,300										
10	67	28,700	76.5	23,500	80	22,000						
12	62	22,800	73.5	20,500	77.5	18,800						
14	57	19,800	70.5	17,700	75.5	16,400	79	15,200				
16	51	17,400	67.5	16,700	73.5	14,600	77	13,300	79.5	12,400		
20	37	13,800	61	12,700	68.5	11,700	73	10,800	76.5	10,000	79	9,500
25			52.5	10,100	62.5	9,400	68.5	8,700	72.5	8,000	75.5	7,800
30			43	8,250	56	7,800	63.5	7,100	68.5	6,500	72	6,100
35			30	6,550	49	6,400	58.5	6,000	64.5	5,450	68.5	5,100
40					41	5,400	53	5,100	60	4,850	65	4,400
45					31.5	4,400	47	4,400	55.5	4,000	61.5	3,800
50					17	3,100	40.5	3,850	51	3,500	57.5	3,250
55							32.5	3,000	45.5	3,000	53.5	2,800
60							22	2,250	40	2,500	49	2,400
65									33	2,050	44.5	2,050
70									25	1,550	39.5	1,700
75									11	700	34	1,350
80											27	1,000
85											17	500
0	0	6,500	0	3,000	0	1,800	0	700				100

LOADLINE EQUIPMENT DEDUCT

DOWNHAUL WEIGHT = 150
 ONE SHEAVE BLOCK = 200
 TWO SHEAVE BLOCK = 355
 THREE SHEAVE BLOCK = 530

National Series 900 Load Ratings Model 990 With 15-Foot Angling Jib

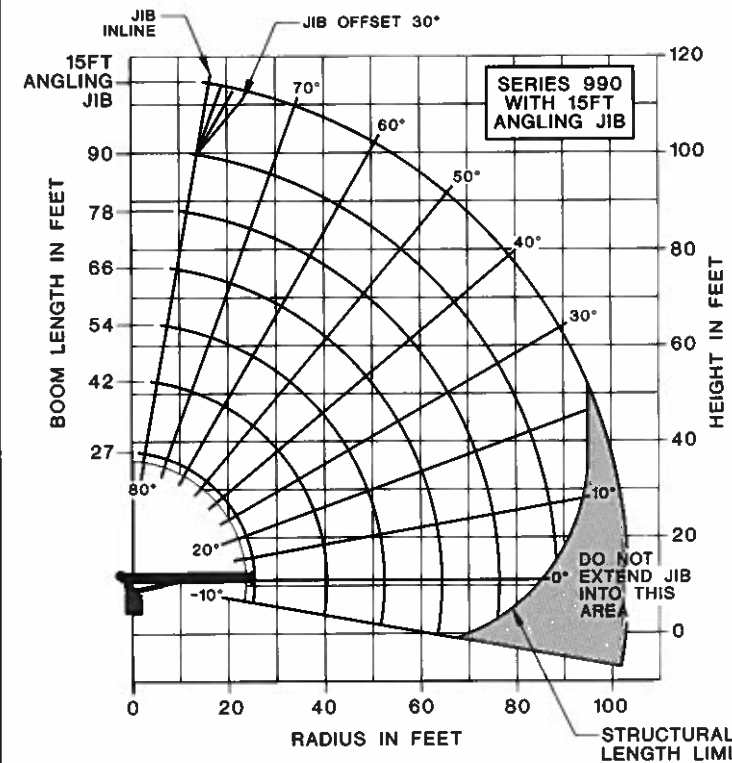

- Notes:**
1. Shaded portions of these charts are the structural strength ratings.
 2. Load ratings shown are maximum allowable loads under optimal conditions.
 3. Rated loads do not exceed 85 percent of the tipping load.

- CAUTION**
- These charts show maximum allowable loads with the crane properly leveled and mounted on a factory-recommended truck, and the outriggers properly extended on a firm, level surface.
 - Always level the crane with the level indicator located on the crane frame.
 - The operator must reduce loads to allow for factors such as wind, ground conditions, operating speeds and the effects of freely suspended loads.
 - Weights of any accessories attached to the boom or load-line must be deducted from the load capacity charts.
 - Crane overload may cause instability or structural collapse.

LMI OPERATING CODE SWITCH	
SWITCH POSITION (REF #17)	OPERATING MODE
01	MAIN BOOM - NO JIB STOWED
02	MAIN BOOM - JIB STOWED
06	15FT ANGLING JIB 0° OFFSET
07	15FT ANGLING JIB 10° OFFSET
08	15FT ANGLING JIB 20° OFFSET
09	15FT ANGLING JIB 30° OFFSET
11	MAN BASKET ON MAIN BOOM
13	MAN BASKET ON 15FT ANGLING JIB 0° OFFSET
14	MAN BASKET ON 15FT ANGLING JIB 10° OFFSET
15	MAN BASKET ON 15FT ANGLING JIB 20° OFFSET
16	MAN BASKET ON 15FT ANGLING JIB 30° OFFSET

LOAD RATINGS												JIB LOAD RATINGS (SAME CAPACITY FOR ANY OFFSET ANGLE)			
LOAD RADIUS (FEET)	LOADED BOOM ANGLE	27FT BOOM (LBS)	LOADED BOOM ANGLE	42FT BOOM (LBS)	LOADED BOOM ANGLE	54FT BOOM (LBS)	LOADED BOOM ANGLE	66FT BOOM (LBS)	LOADED BOOM ANGLE	78FT BOOM (LBS)	LOADED BOOM ANGLE	90FT BOOM (LBS)	LOAD RADIUS (FEET)	LOADED BOOM ANGLE	CAPACITY (LBS)
5	79	48,000											25	79	6,000*
8	72	32,300											30	78.5	5,150
10	67	28,700	76.5	23,500	80	22,000							35	75.5	4,300
12	62	22,800	73.5	20,500	77.5	18,800							40	72.5	3,650
14	57	19,800	70.5	17,700	75.5	16,400	79	15,200					45	69.5	3,100
16	51	17,400	67.5	16,700	73.5	14,600	77	13,300	79.5	12,400			50	66	2,800
20	37	13,800	61	12,700	68.5	11,700	73	10,800	76.5	10,000	79	9,500	55	63	2,300
25			52.5	10,100	62.5	9,400	68.5	8,700	72.5	8,000	75.5	7,800	60	59	2,000
30			43	8,250	56	7,800	63.5	7,100	68.5	6,500	72	6,100	65	55.5	1,800
35			30	6,550	49	6,400	58.5	6,000	64.5	5,450	68.5	5,100	70	52	1,350
40					41	5,400	53	5,100	60	4,850	65	4,400	75	47.5	1,050
45					31.5	4,400	47	4,400	55.5	4,000	61.5	3,800	80	43	850
50					17	3,100	40.5	3,850	51	3,500	57.5	3,250	85	38.5	600
55							32.5	3,000	45.5	3,000	53.5	2,800	90	32.5	450
60							22	2,250	40	2,500	49	2,400			
65									33	2,050	44.5	2,050			
70									25	1,550	39.5	1,700			
75									11	700	34	1,350			
80											27	1,000			
85											17	500			
0	0	6,500	0	3,000	0	1,800	0	700				100			

*0° AND 10° JIB OFFSET ANGLE ONLY

LOADLINE EQUIPMENT DEDUCT

DOWNHAUL WEIGHT = 150
 ONE SHEAVE BLOCK = 200
 TWO SHEAVE BLOCK = 355
 THREE SHEAVE BLOCK = 530

National Series 900 Truck Specifications

Mounting configurations		Configuration 1 (with torsion box): 180-degree capacity	Configuration 2 (with torsion box): 360-degree capacity
The versatility of your National crane can be enhanced by the mounting configurations described at right, based on the Series 900 with an 85 percent stability factor. The complete unit must be installed in accordance with factory requirements and (since individual truck chassis vary) a test performed to determine actual stability and counterweight requirements. Contact the factory for details.		This configuration, with the crane mounted behind the truck cab, is the least expensive mounting method available. Requiring the least weight for stability, this mount lets you haul larger payloads. Standard subbase and rear (RSOD) stabilizers are required.	This mount requires front stabilizers to give the machine full capacity for 360 degrees around the truck. Careful truck selection is necessary, as it must meet the minimum requirements shown below. The front stabilizer gives the machine a solid base, helping the operator control loads with precision. Front and rear down-and-out stabilizers and a subbase are required. The truck frame must be constructed from 110,000 psi (7,590 bar) steel (50,000 psi option not applicable).
Stable		180 degrees	360 degrees
Gross Axle Weight Rating (GAWR)—Front		16,000 lb. (7,258 kg)	16,000 lb. (7,258 kg)
Gross Axle Weight Rating (GAWR)—Rear		34,000 lb. (15,422 kg)	34,000 lb. (15,422 kg)
Wheelbase		234 in. (594 cm)	234 in. (594 cm)
Cab to Axle/Trunnion		156 in. (396 cm)	156 in. (396 cm)
Frame Section Modulus Under Crane	50,000 psi (3,450 bar)	35.0 inch ³ (573.7 cm ³)	(Not Applicable)
	110,000 psi (7,590 bar)	15.9 inch ³ (260.6 cm ³)	20.0 inch ³ (327.8 cm ³)
Frame Section Modulus Over Rear Stabilizers	50,000 psi (3,450 bar)	17.0 inch ³ (278.6 cm ³)	(Not Applicable)
	110,000 psi (7,590 bar)	13.0 inch ³ (213.1 cm ³)	13.0 inch ³ (213.1 cm ³)
Stability Weight, Front		7,500 lb. (3,402 kg) minimum*	7,500 lb. (3,402 kg) minimum*
Stability Weight, Rear		9,100 lb. (4,128 kg) minimum, RSOD*	9,100 lb. (4,128 kg) minimum, RSOD*
Estimated Average Final Weight		37,500 lb. (17,010 kg)	37,500 lb. (17,010 kg)
Notes: 1. Gross Axle Weight Rating (GAWR) is dependent on all components of the vehicle (axles, tires, springs, frame, etc.) meeting manufacturer's recommendations. Always specify GAWR when purchasing trucks. 2. Minimum axle requirements may increase with use of a longer wheelbase, service bodies, diesel engines or front stabilizers. 3. Diesel engines require a variable speed governor and energize-to-run fuel solenoid for smooth crane operation. * Estimated axle scale weights prior to installation of crane, stabilizers and subbase for 85 percent stability			

Configuration 3 (with torsion box): 360-degree rear-mount
A rear-mounted crane gives the operator the advantage of lifting heavier loads within the close-in work area and offers 360-degree stability at full-rated load. Hydraulic out-and-down outriggers are necessary, located behind the cab to keep total unit weight to a full-stability minimum. Front over frame outriggers and a heavy-duty rear-mount subbase are required. Counterweight may also be needed to ensure stability.
360 degrees
16,000 lb. (7,258 kg)
34,000 lb. (15,422 kg)
234 in. (594 cm)
156 in. (396 cm)
35.0 inch ³ (573.7 cm ³)
15.9 inch ³ (260.6 cm ³)
35.0 inch ³ (573.7 cm ³)
15.9 inch ³ (260.6 cm ³)
7,700 lb. (3,493 kg) minimum*
8,500 lb. (3,856 kg) minimum*
40,300 lb. (18,280 kg)

Truck Frame and Mounting Bolt Requirements for Front Stabilizer

The truck frame must have adequate strength from under the crane frame through the front suspension to the bumper assembly for front stabilizer installation. A truck frame yield strength of 110,000 psi (7,586 bar) is required.

The following diagram shows the required section modulus at various stations along the front end of the truck frame for a standard behind-the-cab mount.

Note in the sample cross-sections that the truck frame top flange width is decreased in the engine compartment area. Also note that almost half the truck frame channel is removed at the very front of the frame on the standard truck frame.

In order to safely mount a front stabilizer in place of the normal front bumper, a minimum bolt pattern as shown is required. The bracket must be capable of supporting .50 DIA, Grade 8 bolts to their nominal breaking strength. Torque the mounting bolts supplied with the front stabilizer to 100 ft-lb. Do not use spacers between the bumper bracket and the front stabilizer bumper assembly. If the bumper bracket and front of the truck frame do not meet these specifications, an extended frame truck must be used. Contact the factory for details. Details for mounting a stabilizer on an extended frame truck are included in the installation instructions. However, the Section Modulus requirements outlined above do still apply.

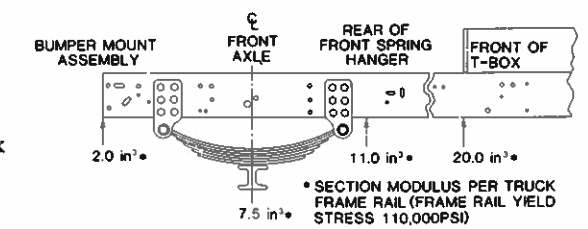

Standard Truck Frame—for angled single front stabilizer only

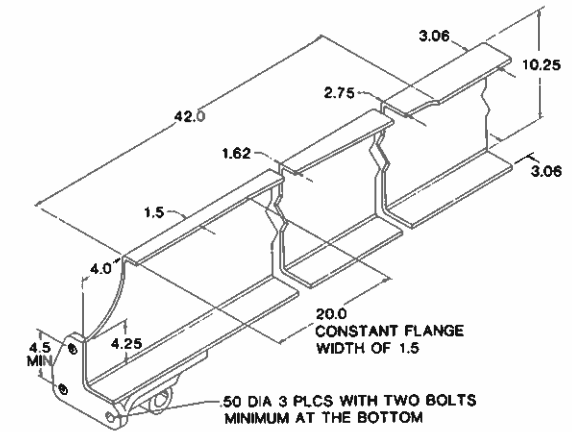

Extended Truck Frame—for angled or straight down single front stabilizer

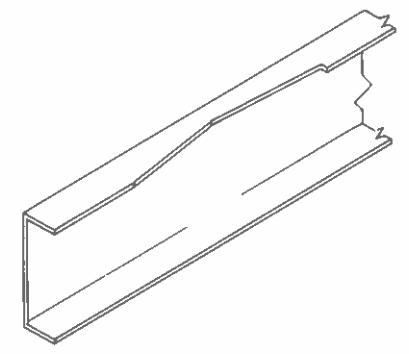

National Series 900 Accessories

Accessories for an array of jobs add to the versatility of a National crane. A partial list of some of the most popular follows. Weights for all accessories attached to the boom or loadline of the crane must be deducted from the effective lifting capacity. Some accessories cannot be used in combination with other accessories and/or jibs. Consult your National dealer for specific availability.

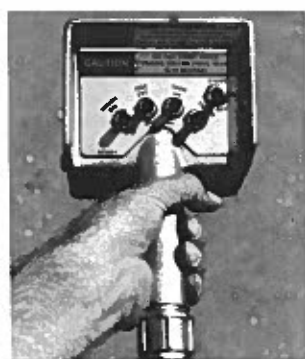

Remote controls

- Model R3, cabled remote for tilt, turn and telescope control
- Model R4, cabled remote for tilt, turn, telescope and winch control
- Model R4B, cabled remote for tilt, turn, telescope, winch and basket control

National offers a variety of one-hand remotes to position loads or platforms with precision and total visibility from any location. Designed for ease of use and reliability, National remotes utilize solid state circuitry, few moving parts and 40 ft. (12.2 m) of control cable.



Radio remote controls

- Model R3R, cable-free performance of R3 functions
- Model R4BR, cable-free performance of R4B functions

A coded FM signal operates National radio remotes to a range of 400 ft. (122 m), eliminating the handling and maintenance cabled remotes require.

Hydraulic Capacity Alert system

• Model HCA
A hydraulically operated, maximum capacity sensing device, the HCA is designed to stop normal functions causing overload as maximum capacity is exceeded on the main boom. May be substituted for the standard Load Moment Indicator (LMI). LMI is required on machines with jibs and baskets.

CAUTION
Do not operate crane booms, jib extensions, any accessories or loads within 10 feet (3 meters) of live power lines or other conductors of electricity • Jib and boom capacities shown are maximum for each section • Do not exceed capacities at reduced radii.

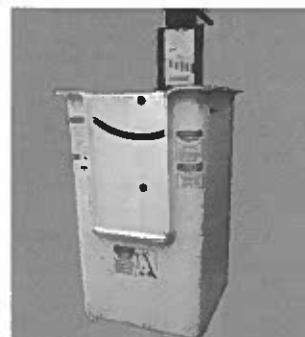

One person basket

- Model B1-L, with lock
- Model 2B1-L (for dual baskets)

A strong, lightweight, fiberglass basket with 300-lb. (136-kg) capacity. An optional dual basket bracket is available for two-basket operation on main boom and jib. Safety belts included. Crane with basket(s) must not be operated where the load chart shows less than the following capacities: one basket—1,100 lb. (499 kg); two baskets—2,000 lb. (907 kg).



Heavy-duty personnel basket

• Model BSA-1
A 1,200-lb. (544-kg) capacity steel personnel basket with safety loops to secure up to four passengers. Gravity-leveling, 72 x 42-in. (183 x 107-cm) platform. Fast attachment system for easy pinning of the basket to boom. Secure

disc-brake locking system. Must not be operated where load chart shows less than 2,300 lb. (1,043 kg).

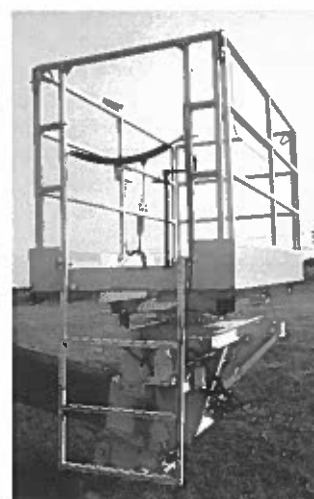

Personnel platform

- Model SLP
- Model SLPR, 360-degree continuous manual rotation

An extra-strength 72 x 36-in. (183 x 91-cm) steel platform, hydraulically self-leveling and protected by safety valves. Safety belts and fold down sides standard. Platform must not be operated where load chart shows less than the following capacities: SLP—2,000 lb. (907 kg); SLPR—2,200 lb. (998 kg).

Note:
Personnel basket/platform operation limits vary based on crane configuration and basket type. Refer to the Owner's Manual for complete details and operation restrictions.



Pallet fork

• Model MKF
A manual-leveling pallet fork with adjustable throat and teeth. 300-lb. (136-kg) fork has 4,400-lb. (1,996-kg) capacity, 41- to 65-in. (104- to 165-cm) throat opening, 38.5-in. (98-cm) tooth length, and 33.5- to 57-in. (85- to 145-cm) tooth width.

Hydraulic oil cooler

• Model OC
This automatic, self-contained radiator system with electric fans cools oil under continuous operation.



Loose material clam bucket

• Model LMC
Move as much as 2/3 cu.yd. (.50 m³) of loose material with each bite. Hooks easily to loadline. Includes manual control hose reel and hydraulic hoses draped through bucket. Additional weight, 920 lb. (417 kg).

Stabilizers and cross-frame outriggers

National Crane offers a complete range of front and rear stabilizers with all-hydraulic vertical and horizontal motion. All cylinders are fully enclosed for protection against dirt and on-the-job damage.



Model RSOD

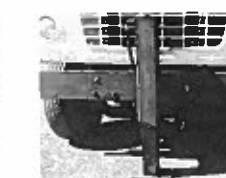

Model SFO(A)*

Stabilizers

Vertical travel	25.5 in. (65 cm)	25 in. (64 cm)
Ground penetration (38 in./97 cm frame height)	10 in. (25 cm)	13 in. (33 cm)
Span	14 ft. (4.3 m)	Single
Controls	Both are operable from either station	
Mounted	Rear	Front

* The SFO and SFOA are both single front-mounted hydraulic stabilizers. Neither is designed to lift the vehicle, but both will provide stability for the vehicle after it has been leveled. Model SFO is for use only on extended-frame chassis. SFOA is for use on standard frame trucks.



Pole grab

• Model PG
A tilting pole grab with hydraulic hose reel, the 650-lb. (295-kg) grab tilts, opens and closes hydraulically for large pole alignment.



Augers

A 14,000 ft-lb (1.93 t-m), two-speed auger attachment with console control. Auger flightings in 12-, 18-, 24- and 36-in. (31-, 46-, 61- and 91-cm) diameters. Additional weight, 1,605-1,870 lb. (728-848 kg).

Cross-frame Outriggers

• Model 9HO
Extended span.....15 ft. 6 in. (4.7 m)
Retracted span7 ft. 11 in. (2.4 m)
Vertical travel
Over-frame25 in. (64 cm)
Under-frame18 in. (46 cm)
Ground penetration (38 in./97 in. frame height)10 in. (25 cm)

National Series 900 General Specifications

General construction

The Series 900 is constructed using low-alloy, high strength steel (T-1, Exten, Stress Proof and others), combined with special low-hydrogen welding techniques wherever advantageous. The standard painted color is National Ivory.

Subbase/frame

A unitized box construction, 8.75-in. (222-mm) deep subbase increases torsional stiffness and reduces truck frame requirements. The standard subbase attaches to both the truck frame and crane frame, fits on a 34-in. (86-cm) wide truck frame and will accommodate a 20-ft. (6.1-m) stringerless bed. Rotation bearing and level indicator surfaces are precision-machined after welding to ensure accurate alignment and flat surfaces for prolonged life.

Turret

The turret is a fabricated rigid structure, well braced for stability. The bearing surface, rotation gearbox mounting and pivot pins are line-bored and machined after welding to ensure accurate alignment and flat surfaces for prolonged life.

Rotation

Features 375-degree non-continuous rotation, and rotation force of 31,667 ft-lb (4.38 t-m). Turret rotation is powered by a hydraulic orbit motor and planetary gearbox driving a pinion. The turret rotates on a ball bearing race. A spring-applied hydraulic release brake provides positive no-drift lateral positioning.

Outriggers

An A-frame box-type outrigger with 21-ft. (6.4-m) span (center of pad at ground level) that will not bind when raising or lowering the truck. It can be positioned to 10.5 in. (27 cm) below ground level when mounted on a truck with a frame height of 38 in. (97 cm).

Lift cylinder

A double-acting hydraulic cylinder raises and lowers the boom. A butt-mounted safety holding valve prevents the boom from falling in the event of a hose failure. Tough, field-tested bearings in the lift cylinder and boom pivot, combined with micro-honed pins, provide long life with reduced maintenance.

Boom

Box construction sections telescope proportionally under rated loads using a double-acting hydraulic cylinder with proportioning cables. Nylon boom wear pads are impregnated with molybdenum disulfide for smooth, durable operation and extension of maximum loads at greater radii. Heavy-duty pivot bearings. Boom cylinder and valves are easily serviced.

Winch

A hydraulic geroller motor with planetary gear reduction brake and counter-balance valve for "power down" load lowering. 10,000 lb. (4536 kg) bare drum single-line pull is available with 320 ft. (98 m) of rotation-resistant, 9/16-in. (14-mm) diameter, 38,500 lb. (17.46 MT) breaking strength loadline. *Burst of Speed* controls payout and pickup of unloaded cable by 60 percent over the normal operating speed.

Pump

One high pressure/high speed, vane-type three-section pump independently provides 34 gpm (129 L/min) to winch, 23 gpm (87 L/min) to crane and 8 gpm (30 L/min) to swing for smooth, fast, simultaneous operation.

Oil tank capacities

A 75-gal. (284-L) supply tank is equipped with breather, clean-out, suction strainers and magnetic plug.

Cylinders

Polyurethane cup-type shaft packing. High yield stress relief chrome-plated shafts. Piston sets are polyurethane U-cups with glass-reinforced nylon bearings. Cylinder barrels of micro-honed tubing, with butt-mounted safety check valves.

Valves

Four-way, spring-centered spool-type valves with low spool force and extra-fine metering notches. Independent relief valves protect the hydraulic circuit from overload (crane functions set at 2,950 psi/204 bar, rotation system at 2,350 psi/162 bar and winch system at 3,050 psi/210 bar).

Hose

All high-pressure hose is wire braid-reinforced, with a minimum safety factor of 4 to 1.

Operating speeds

Winch third wrap: 150 fpm (46 m/min). Boom up and down: 23-27 sec. Boom out: 27-90 ft. (8.2-27.4 m), 80 sec. Boom in: 90-27 ft., 77 sec. Turn: 42 sec. When using the remote control, crane function speeds will be reduced by 40 percent to assure smooth operation (speeds assume no load).

National Series 900 Dimensional Specifications

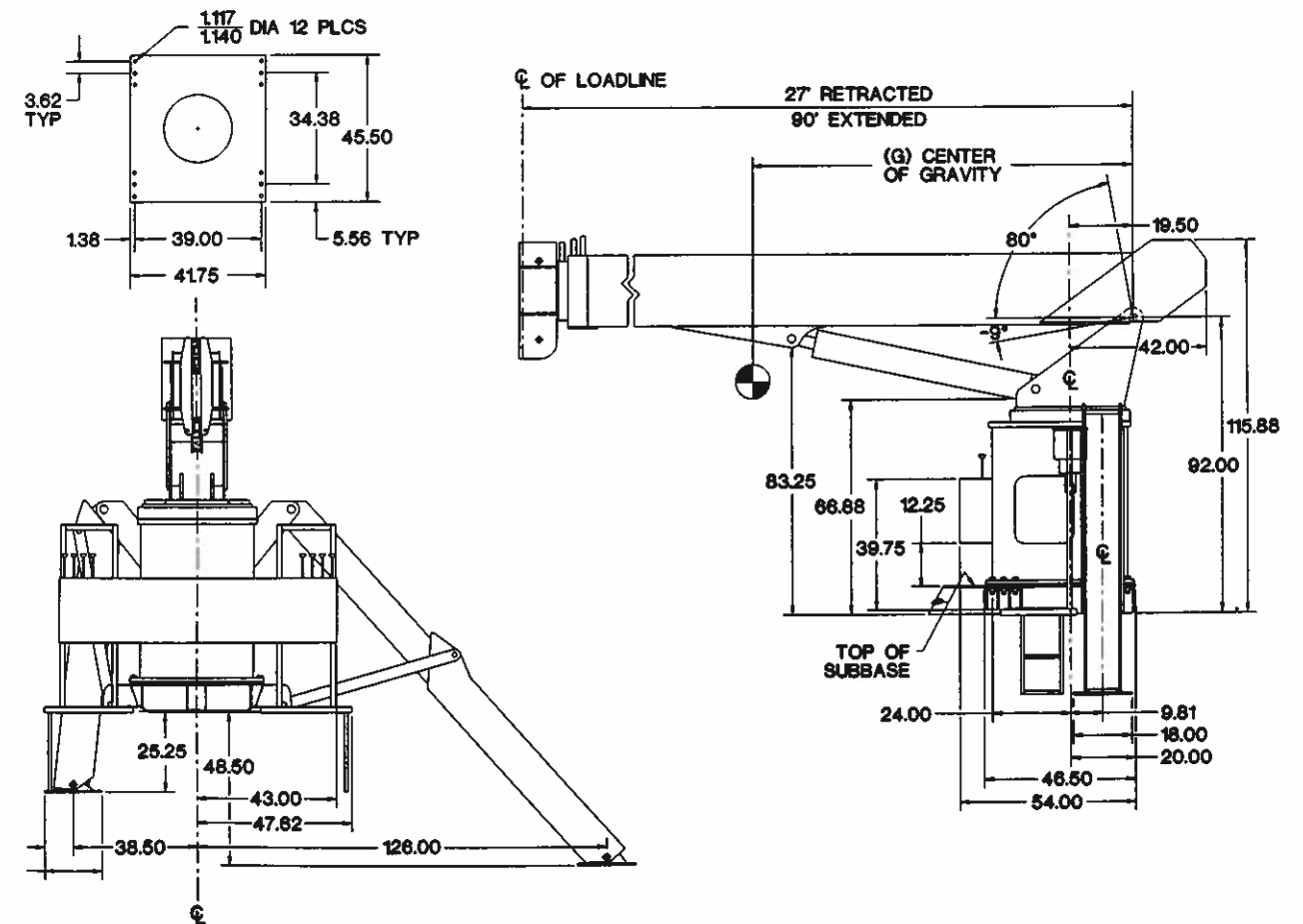

900 Model	Retracted Length	Extended Length	Center of Gravity (G)	Dry Weight*	Weight with Oil*
969	27 ft. (8.2 m)	69 ft. (21.0 m)	90 in. (229 cm)	17,400 lb. (7,893 kg)	18,150 lb. (8,233 kg)
990	27 ft. (8.2 m)	90 ft. (27.4 m)	98 in. (249 cm)	19,000 lb. (8,618 kg)	19,800 lb. (8,981 kg)

* Weight includes all items except RSOD (1,200 lb./544 kg).

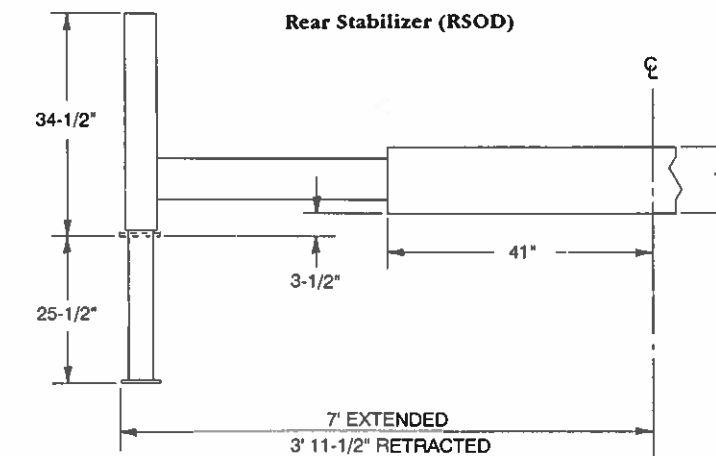

National Series 900 Proposal



General Offices:
 11200 North 148th Street
 Waverly, NE 68462 U.S.A.
 Phone: (402) 786-6300
 FAX: (402) 786-6363

Date: _____

Prepared for: _____

Submitted by: _____

(Firm Name)

(Mailing Address)

(Street Address)

(City)

(State) (ZIP)

(Phone Number)

(FAX Number)

Prepared by: _____

(Name)

(Title)

(Signature)

Description:

- 1. Series: _____
- 2. Boom: _____
- 3. Jib: _____
- 4. Rear Stabilizers: RSOD HO
- 5. Front Stabilizers: SFO
- 6. Line Block: 2-3 Part 4 Part 5 Part 6 Part

Accessories:

- 7. _____
- 8. _____
- 9. _____
- 10. _____

Mounting:

- 11. Installation: Behind Cab Standard Special
- 12. Installation: Rear Mounting (add to installation charge above):.....
 Air Throttle
- Rear-Mount Hydraulic Group.....
- Heavy-Duty Rear Mount Subbase.....
- HO Outriggers.....
- 13. Frame Reinforcement: Weld Bolt-Extra.....
- 14. Platform Body: _____ ft. Wood Steel
- 15. Weight in Bed: _____ lb. (if required).....
- 16. Boom Rest: Parallel Low Other.....
- 17. Mount SFO: _____
- 18. Mount Stabilizers: _____
- 19. Chassis: _____
- 20. Rear Bumper Underride Protection: Yes No.....
- 21. Freight: _____

This quotation will remain firm for _____ days.

Accepted by: _____

(Name)

(Title)

(Firm Name)

(Signature)

Price:

\$ _____

\$ _____
 Total Price

(Date)

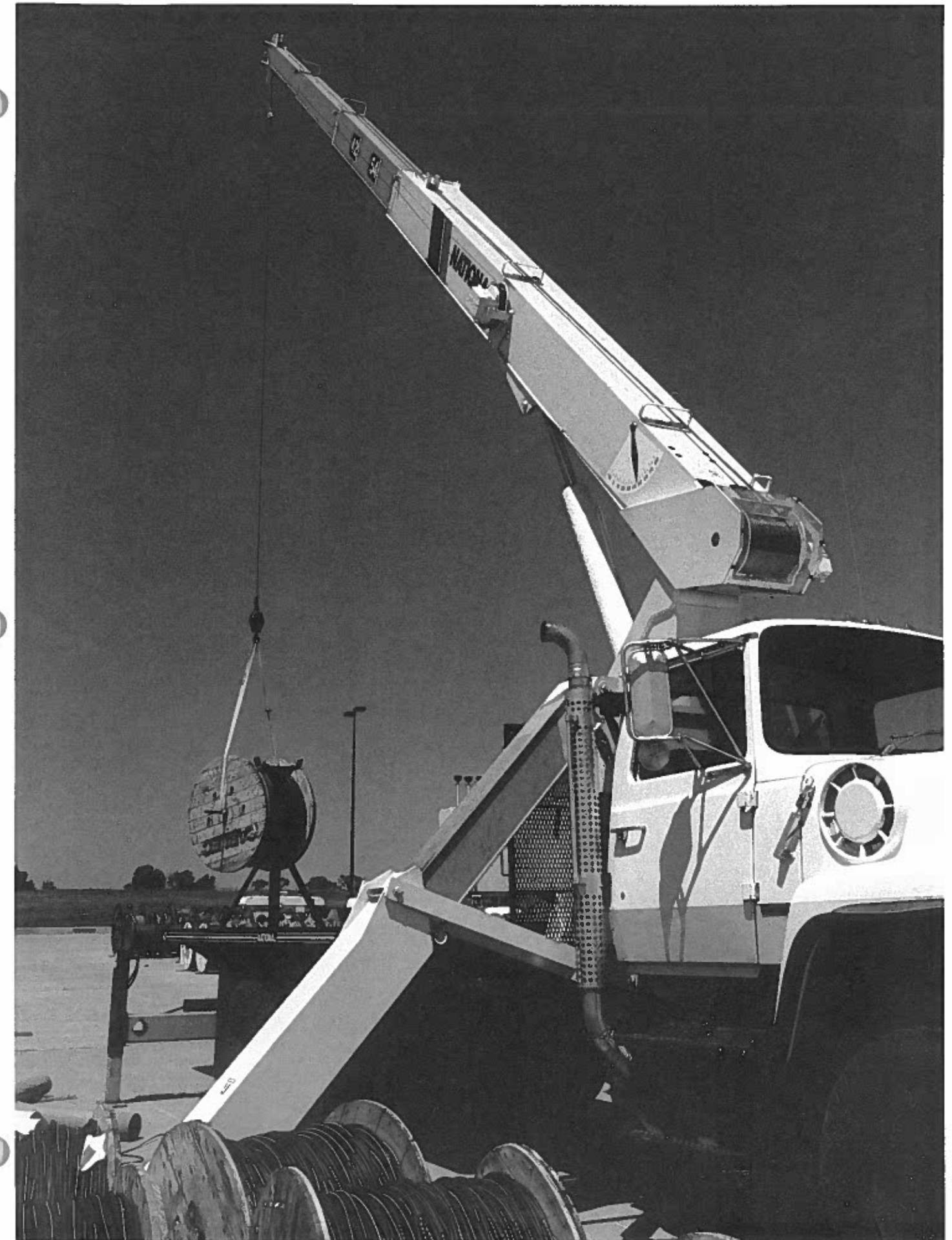



National Series 900 Telescoping Crane



NATIONAL CRANE
A Grove Worldwide Company

General Offices: 11200 North 148th Street • Waverly, NE 68462 U.S.A.
Phone: (402) 786-6300 • FAX: (402) 786-6363

Your National Dealer:

National Crane reserves the right to change designs,
prices and specifications at any time without notice.