Manual # 99905404

11/78 Technical Specifications

Revision 20120210



IOWA MOLD TOOLING CO., INC.

PO Box 189

Garner, IA 50438

Tel: 641-923-3711 FAX: 641-923-2424

Website: <http://www.imt.com>

Copyright © 2012 Iowa Mold Tooling Co., Inc.
All rights reserved

No part of this publication may be reproduced, stored in a retrieval system, or transmitted in any form or by any means, electronic, mechanical, photocopying, recording or otherwise without the prior written permission of Iowa Mold Tooling Co., Inc.

Iowa Mold Tooling Co., Inc. is an Oshkosh Corporation company.

Contents

Technical Data and Charts	3
11/78 Technical Specifications	4
Dimensions & Performance	5
11/78 Series Single Link Capacity Charts	6
11/78 Series Double Link Capacity Charts	11
Dimensions	16
Mounting Dimensions.....	17
Dimensions, Fixed Stabilizer Legs	18
Swing-Up Stabilizer Legs	19
Swing Clearance Drawings.....	22
Single Link Swing Clearance	22
Double Link Swing Clearance.....	23
Pressure Settings & Hydraulic Schematics	25
Pressure Settings	26
Hydraulic Schematic.....	27

CHAPTER 1

Technical Data and Charts

In This Chapter

11/78 Technical Specifications.....	3
Dimensions & Performance.....	5
11/78 Series Single Link Capacity Charts	6
11/78 Series Double Link Capacity Charts.....	11
Dimensions.....	16
Mounting Dimensions.....	17
Dimensions, Fixed Stabilizer Legs	18
Swing-Up Stabilizer Legs	19
Swing Clearance Drawings	22

11/78 Technical Specifications

11/78	1-HYDRAULIC	2-HYDRAULIC	3-HYDRAULIC	4-HYDRAULIC	5-HYDRAULIC
Crane Rating (Single Link)	77,395 ft-lb (10.7 tm)	74,500 ft-lb (10.3 tm)	72,330 ft-lb (10.0 tm)	70,160 ft-lb (9.7 tm)	67,990 ft-lb (9.4 tm)
Crane Rating (Double Link)	76,670 ft-lb (10.6 tm)	73,775 ft-lb (10.2 tm)	71,605 ft-lb (9.9 tm)	69,435 ft-lb (9.6 tm)	67,265 ft-lb (9.3 tm)
Maximum Horizontal Reach	20'-0" (6.1 m)	26'-11" (8.2 m)	34'-5" (10.5 m)	41'-8" (12.7 m)	49'-3" (15.0 m)
Maximum Vertical Reach	27'-5" (8.35 m)	34'-6" (10.5 m)	41'-10" (12.76 m)	46'-5" (15.05 m)	56'-9" (17.31 m)
Capacity - Single Link Cranes					
Maximum Capacity	9170 lb (4160 kg)	8905 lb (4040 kg)	8355 lb (3790 kg)	7870 lb (3570 kg)	7430 lb (3370 kg)
Max Capacity @ Max Reach	3945 lb (1790 kg)	2710 lb (1230 kg)	1920 lb (870 kg)	1390 lb (630 kg)	1015 lb (460 kg)
Capacity - Double Link Cranes					
Maximum Capacity	9280 lb (4210 kg)	8820 lb (4000 kg)	8380 lb (3800 kg)	7980 lb (3620 kg)	7630 lb (3460 kg)
Max Capacity @ Max Reach	3880 lb (1760 kg)	2670 lb (1210 kg)	1875 lb (850 kg)	1365 lb (620 kg)	1015 lb (460 kg)
Crane Weight**	2570 lb (1165 kg)	2845 lb (1290 kg)	3085 lb (1400 kg)	3295 lb (1495 kg)	3485 lb (1580 kg)
Hook Approach					
Vertical	9'-1" (2.78 m)	8'-10" (2.70 m)	8'-6" (2.60 m)	8'-3" (2.51 m)	7'-11" (2.41 m)
Horizontal	2'-7" (0.79 m)	2'-9" (0.84 m)	2'-11" (0.89 m)	3'-1" (0.94 m)	3'-3" (1.0 m)
Center of Gravity-Stored (Single Link)					
Vertical	24.5" (622 mm)	25.8" (654 mm)	26.3" (684 mm)	27.8" (706 mm)	28.5" (725 mm)
Horizontal (C/L Rotation to Bridge)	13.2" (336 mm)	13.1" (332 mm)	12.8" (324 mm)	12.2" (311 mm)	11.7" (298 mm)
Center of Gravity-Stored (Double Link)					
Vertical	25.7" (654 mm)	27" (683 mm)	28" (710 mm)	29" (731 mm)	29.3" (745 mm)
Horizontal (C/L Rotation to Bridge)	12.6" (320 mm)	12.5" (318 mm)	12.2" (311 mm)	11.8" (299 mm)	11.4" (289 mm)

* Crane rating (ft-lb) is the rated load (lb) multiplied by the respective distance (ft) from the centerline of rotation with all extensions retracted, and the inner and outer booms in a horizontal position, per ANSI B30.22.

** Crane weight is for standard single-link crane with tank & mounting kit. Does not include stabilizers, oil. Add 75 lb (35 kg) for double link.

Dimensions & Performance

DIMENSIONS & PERFORMANCE	
Crane Storage Height	7'-0" (2135 mm)
Width	8'-2" (2500 mm)
Mounting Space	2'-5" (747 mm)
Maximum Swing Clearance (from top of chassis frame)	23.1" (587 mm) at 7'-7" (2313 mm)
Rotational Torque	9665 ft-lb (1.3 tm)
Rotation	420 degrees
Optimum Pump Performance	10.5 GPM (40 L/min)
System Pressure	4350 psi (300 bar)
Oil Reservoir Capacity	17.2 gal (65 L)

STABILIZERS	
Stabilizer Pad Diameter	6" (158 mm)
Stabilizer Weights	
Standard Man Out/Hyd Down, Fixed	375 lb (170 kg)
Standard Man Out/Hyd Down, Swing-Up	385 lb (175 kg)
Extended Reach Hyd Out/Down, Fixed	430 lb (195 kg)
Extended Reach Hyd Out/Down, Swing Up	440 lb (200 kg)
Stabilizer Spread, Standard	15'-2" (4615 mm)
Stabilizer Spread, Extended Reach	18'-4" (5590 mm)

CHASSIS SPECIFICATIONS	
Front Axle Rating (GAWR)	8000 lb (3630 kg)
Rear Axle Rating (GAWR)	16,000 lb (7260 kg)
Resistance to Bending Moment	1,170,000 in-lb (134,800 kg-m)

11/78 Series Single Link Capacity Charts

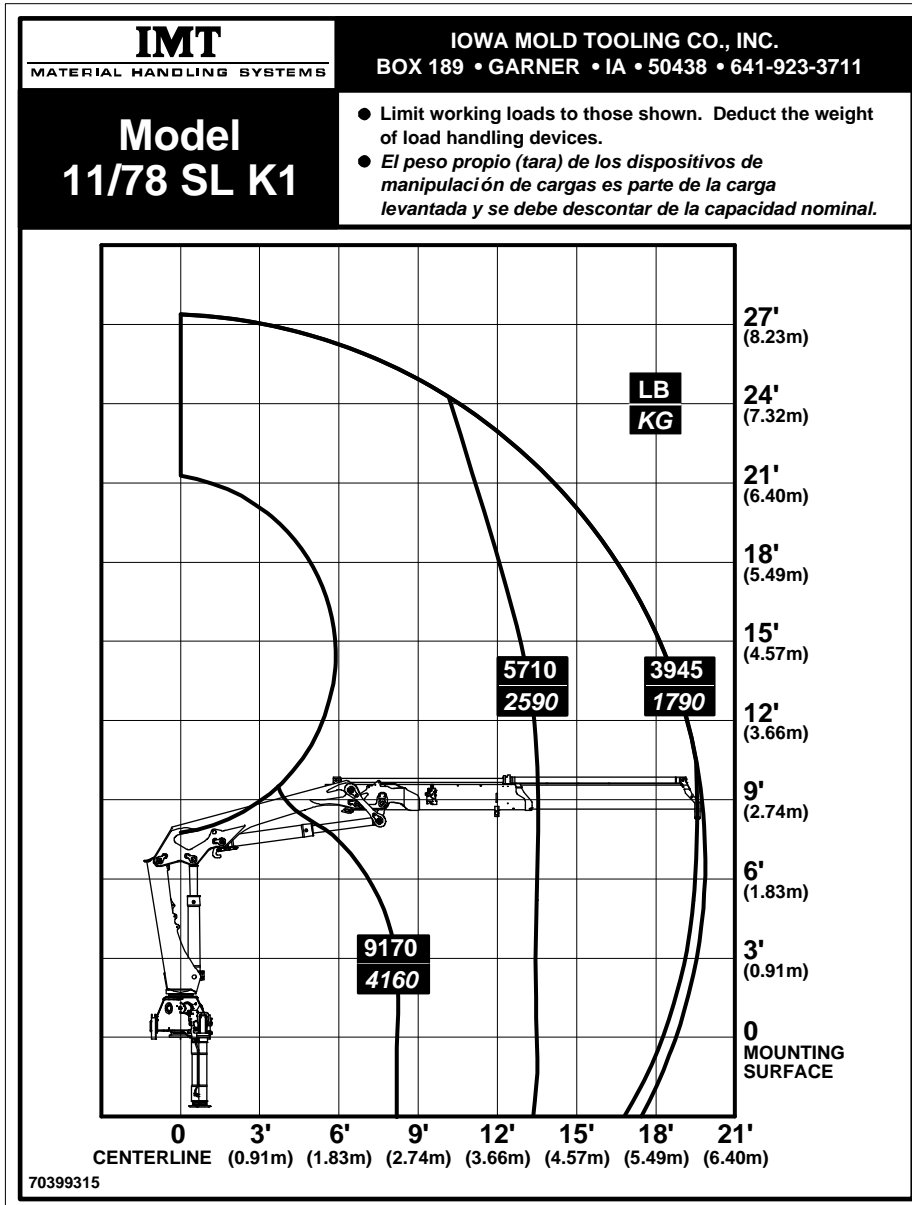

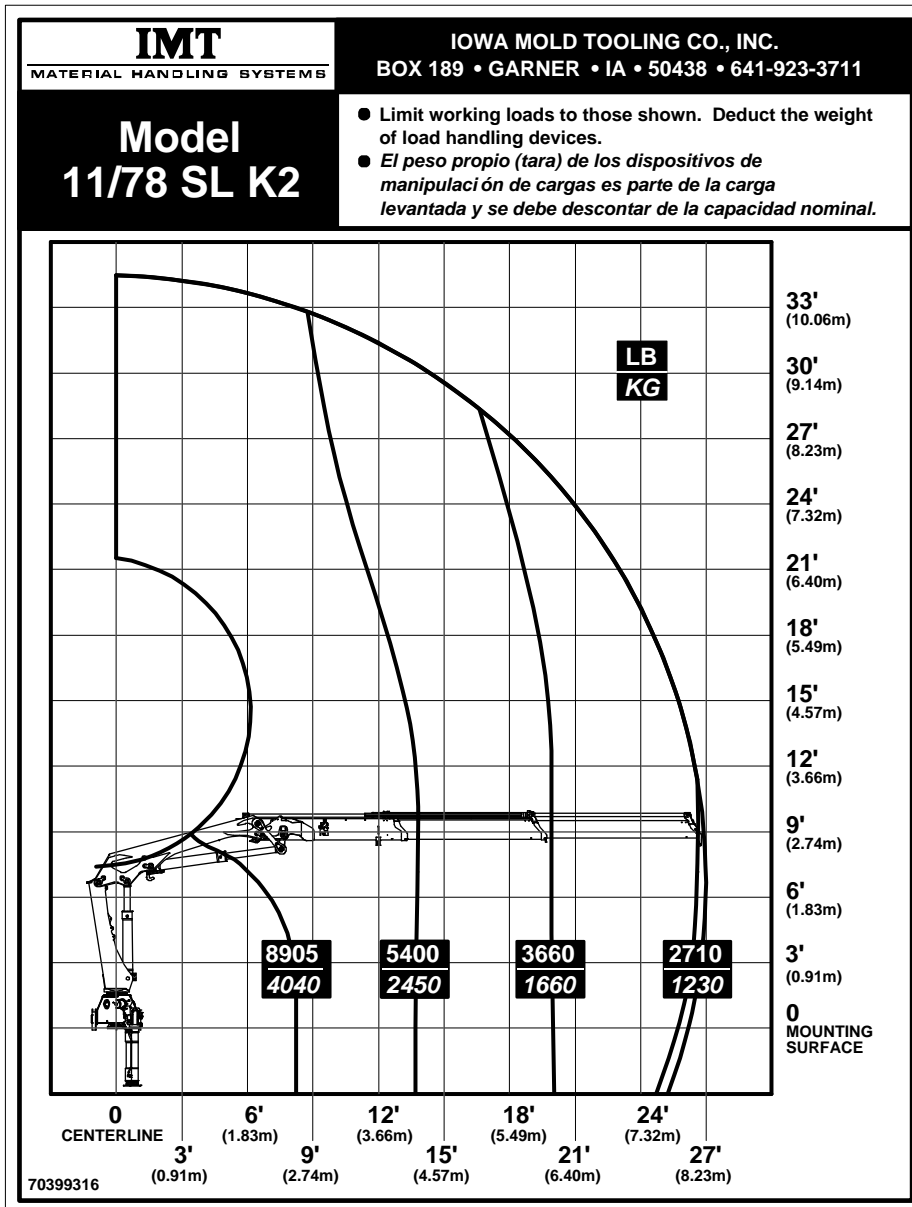

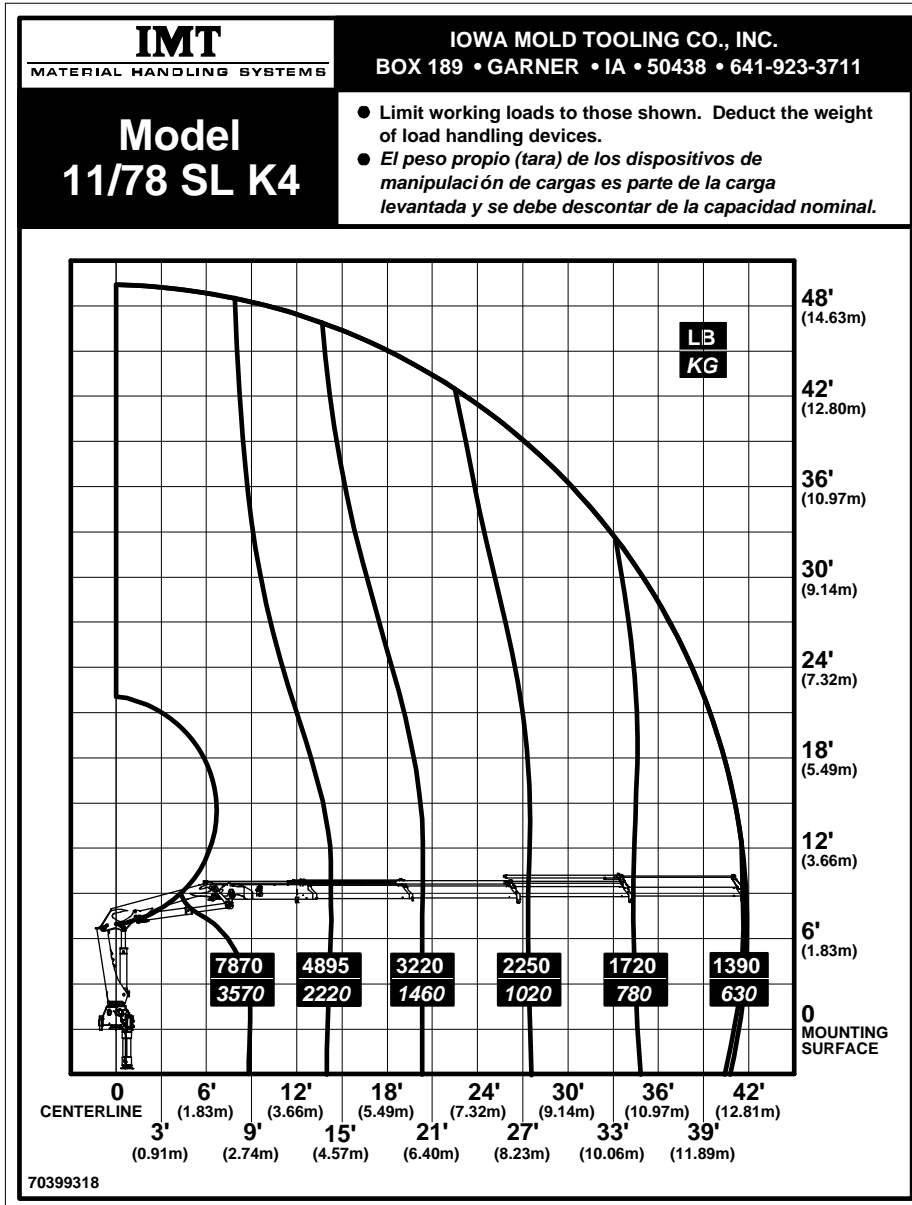

IMT
MATERIAL HANDLING SYSTEMS

IOWA MOLD TOOLING CO., INC.
BOX 189 • GARNER • IA • 50438 • 641-923-3711

**Model
11/78 SL K5**

- Limit working loads to those shown. Deduct the weight of load handling devices.
- *El peso propio (tara) de los dispositivos de manipulación de cargas es parte de la carga levantada y se debe descontar de la capacidad nominal.*

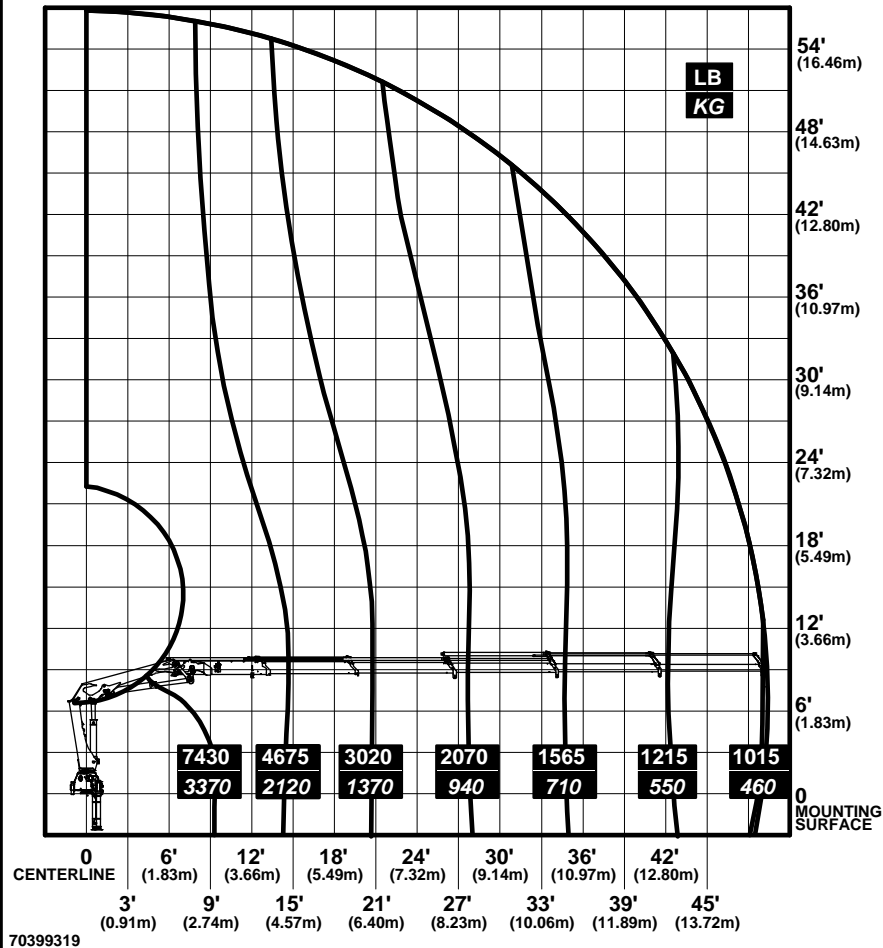

11/78 Series Double Link Capacity Charts

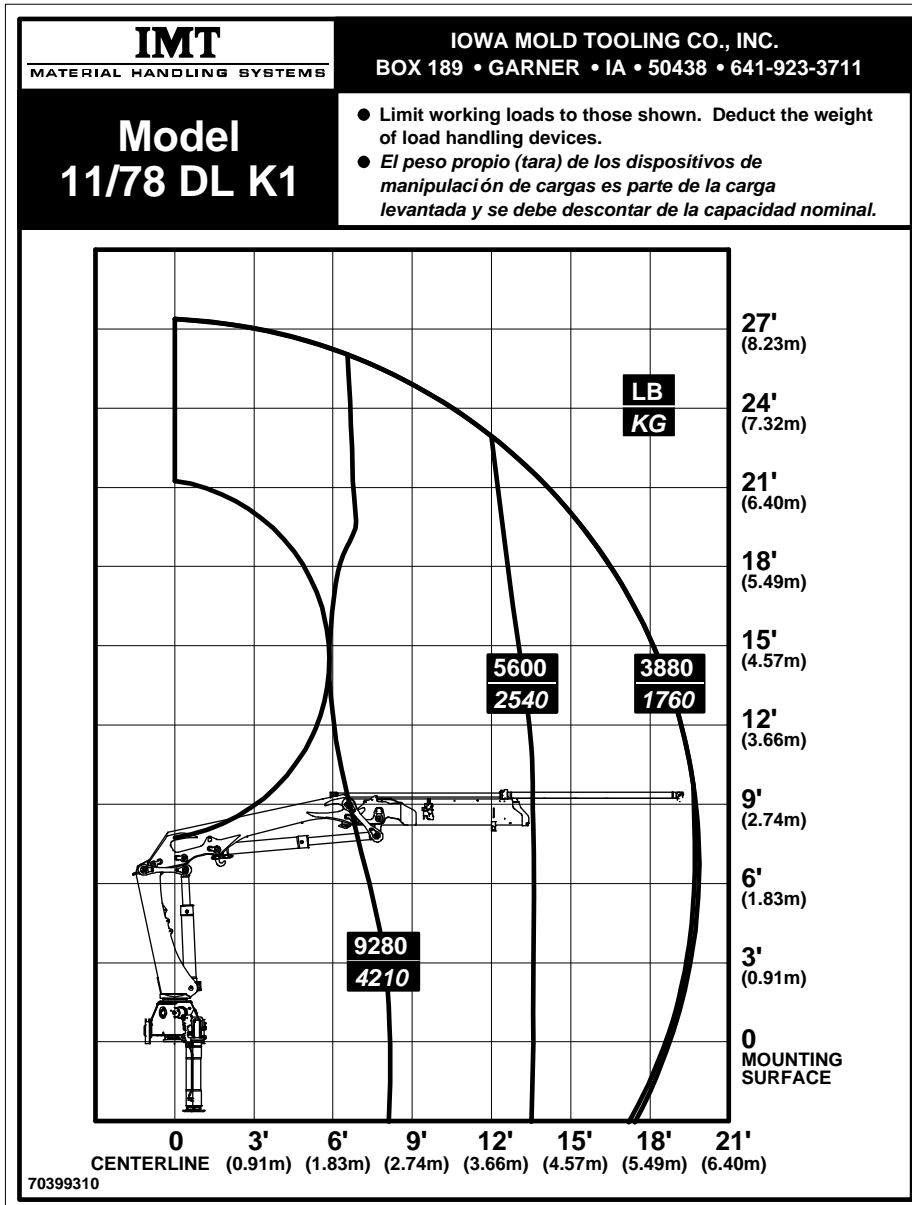

IMT
MATERIAL HANDLING SYSTEMS

IOWA MOLD TOOLING CO., INC.
BOX 189 • GARNER • IA • 50438 • 641-923-3711

**Model
11/78 DL K2**

- Limit working loads to those shown. Deduct the weight of load handling devices.
- *El peso propio (tara) de los dispositivos de manipulación de cargas es parte de la carga levantada y se debe descontar de la capacidad nominal.*

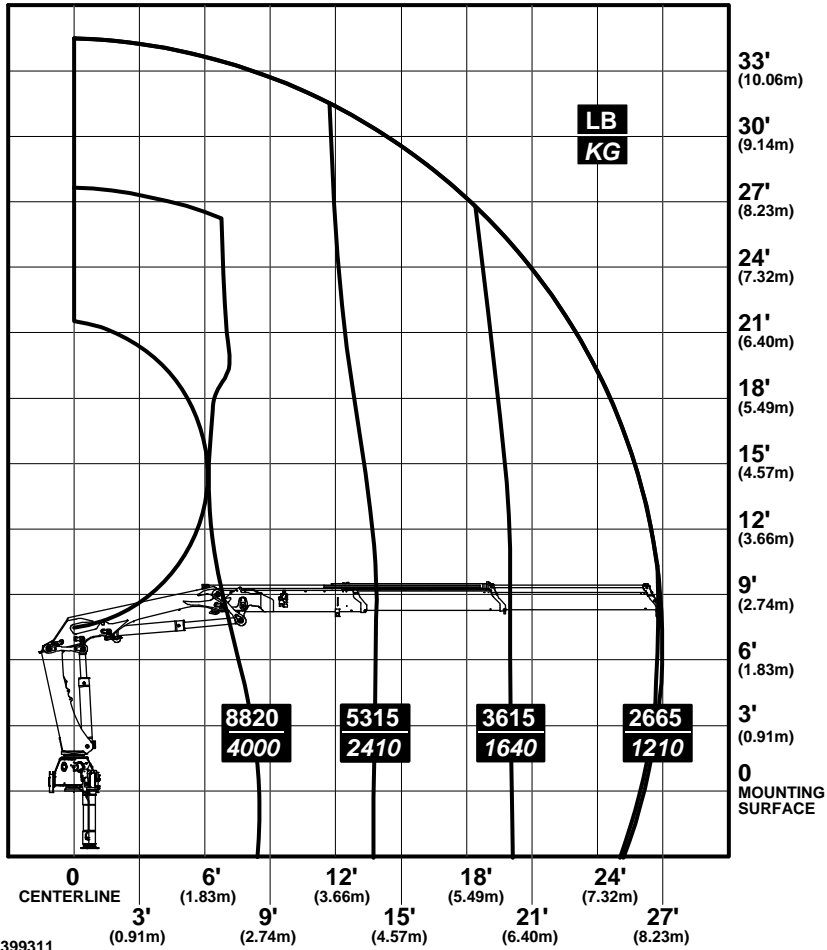

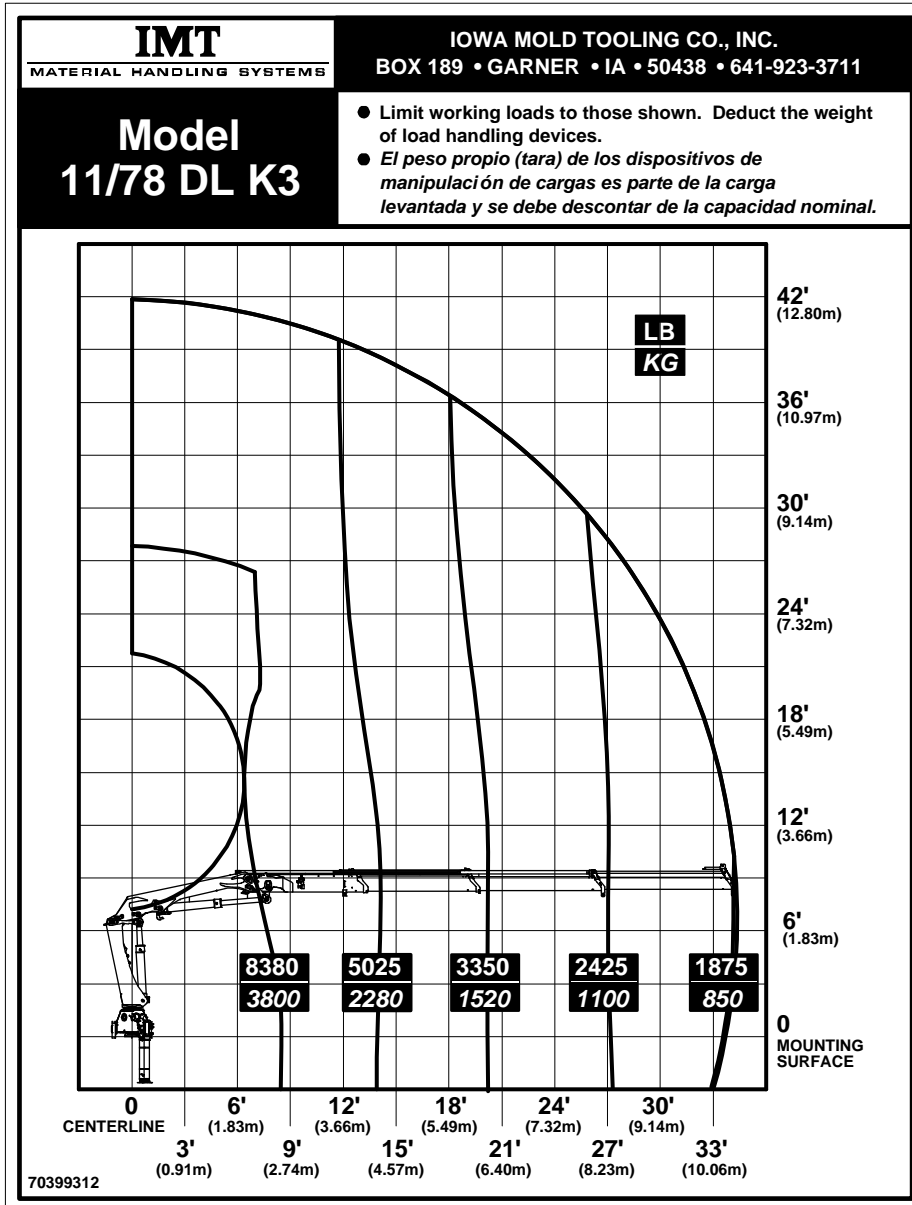

IMT
MATERIAL HANDLING SYSTEMS

IOWA MOLD TOOLING CO., INC.
BOX 189 • GARNER • IA • 50438 • 641-923-3711

Model 11/78 DL K4

- Limit working loads to those shown. Deduct the weight of load handling devices.
- *El peso propio (tara) de los dispositivos de manipulación de cargas es parte de la carga levantada y se debe descontar de la capacidad nominal.*

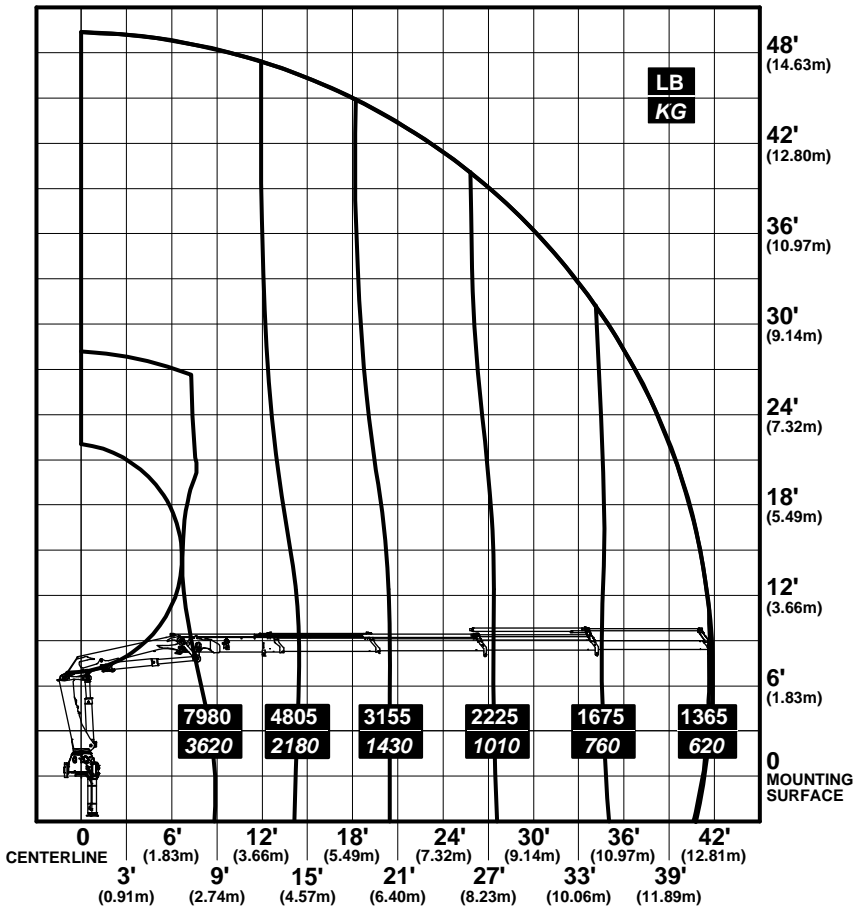

70399313

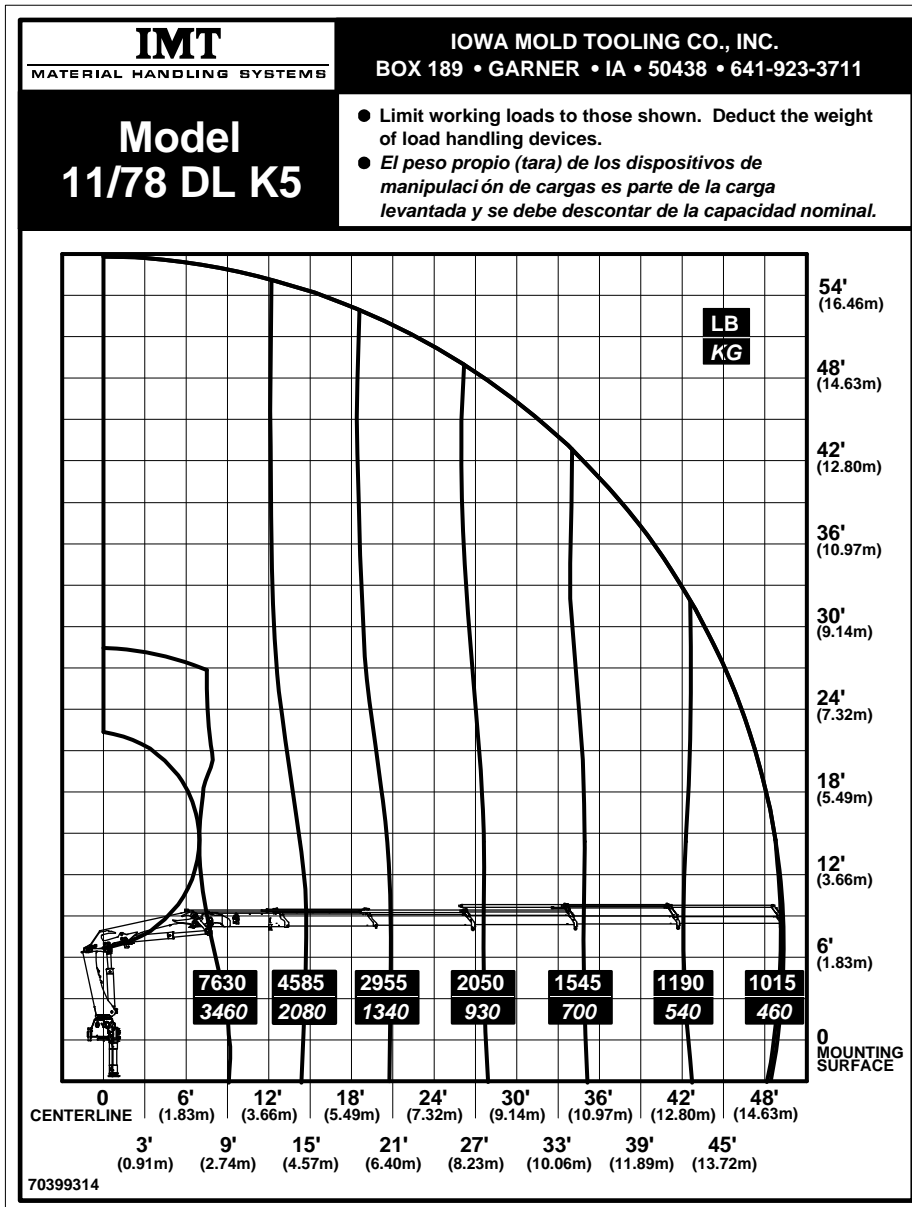

Dimensions

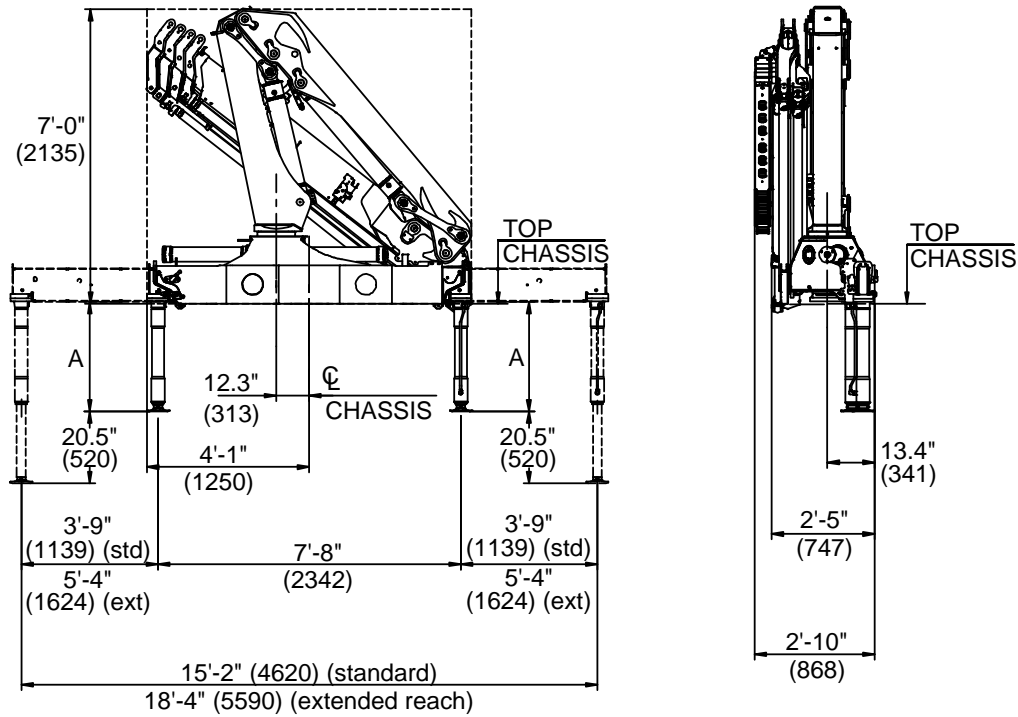
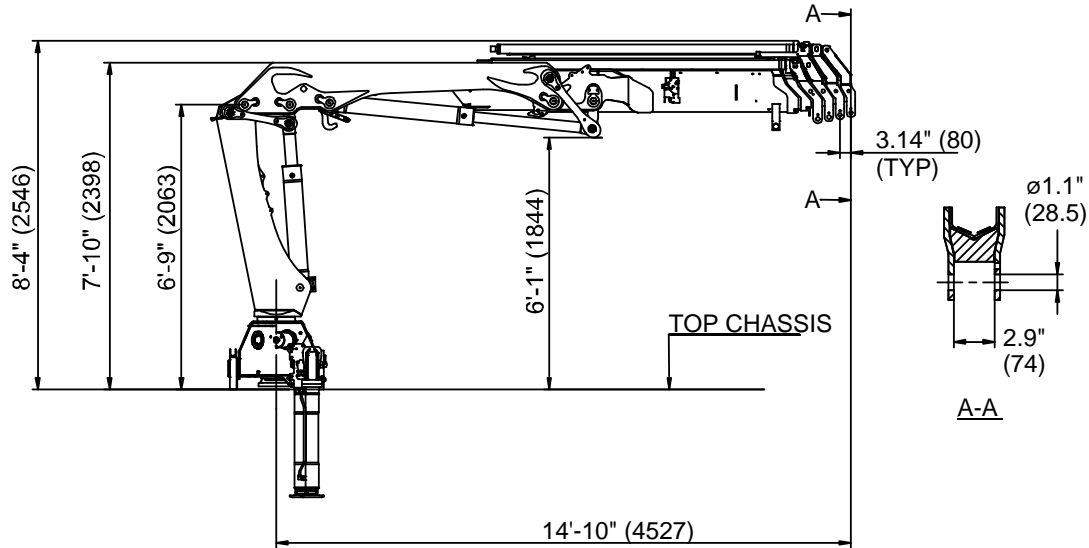

Double link crane shown. Single link dimensions are the same.
 Dimensions shown in ft-in (mm).

Mounting Dimensions

8 mounting holes - M24 x 2 bolt

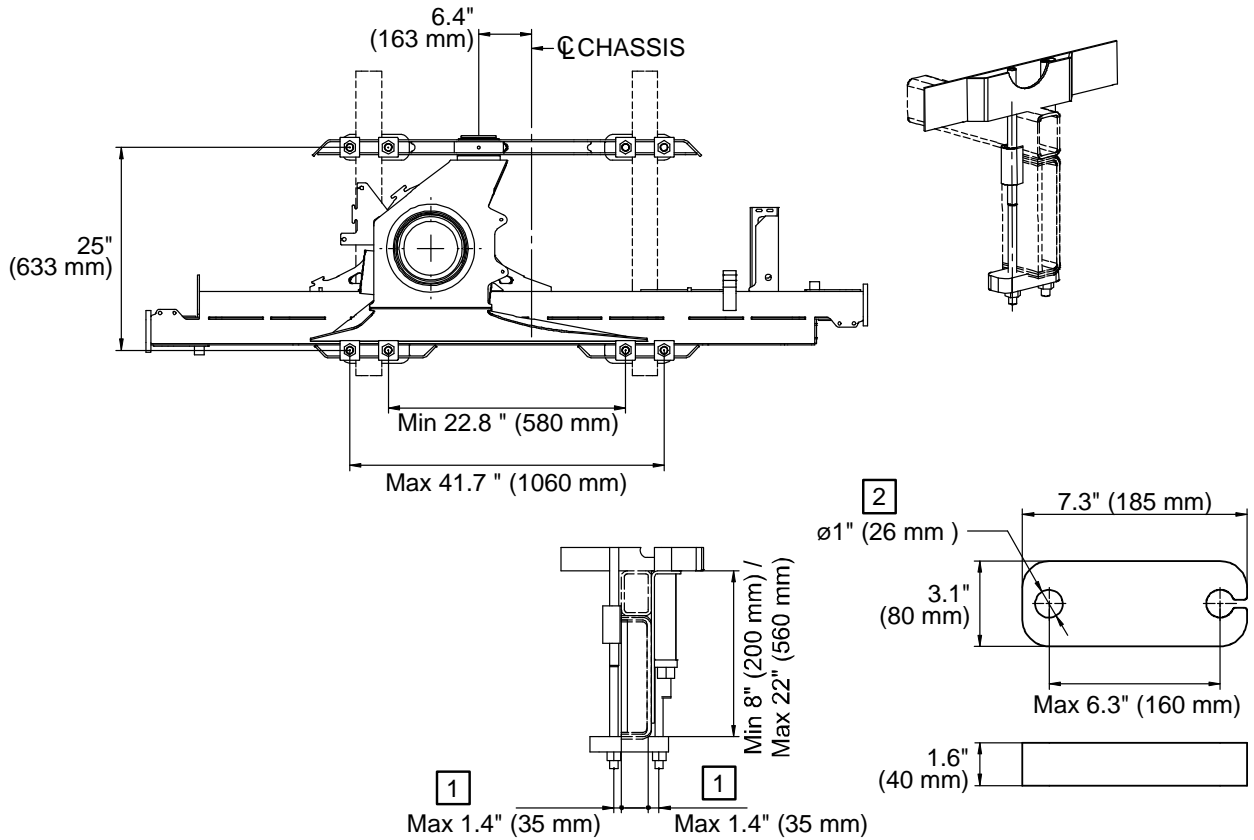

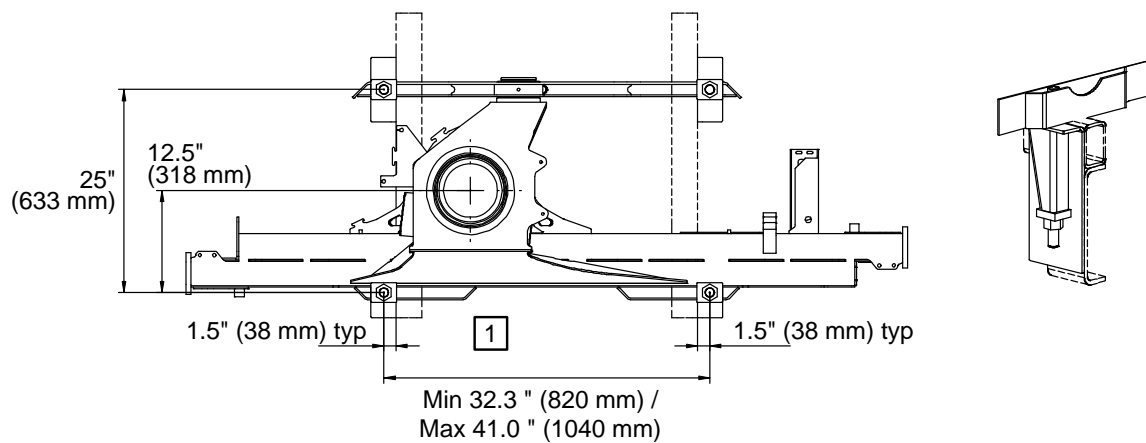

4 mounting holes - M30 x 2 bolt



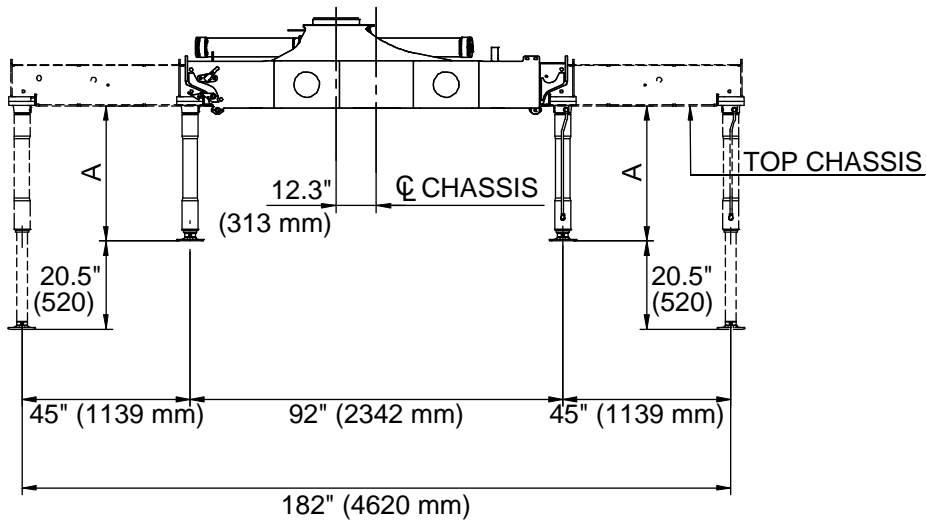
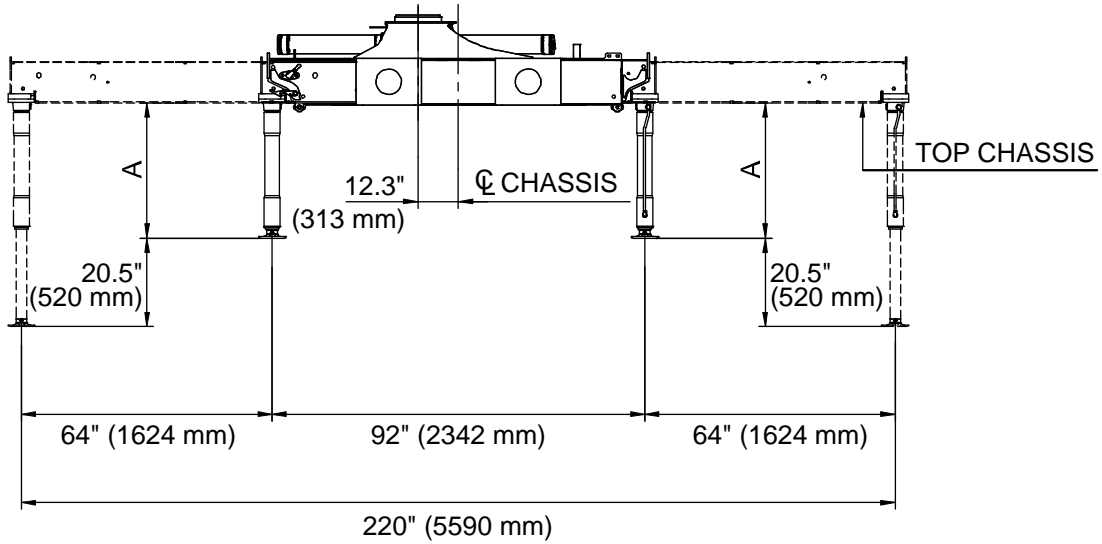



Dimensions, Fixed Stabilizer Legs

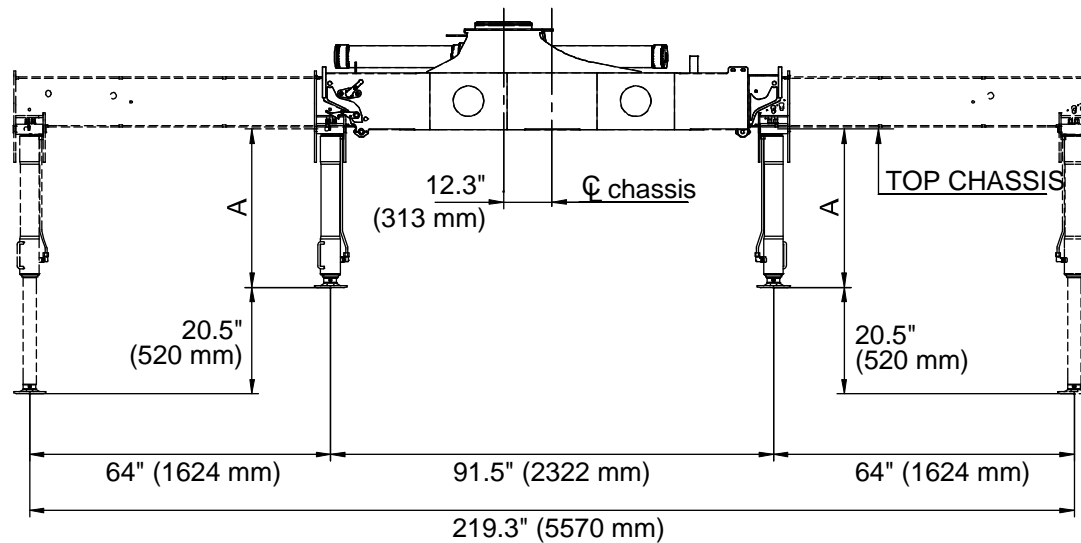
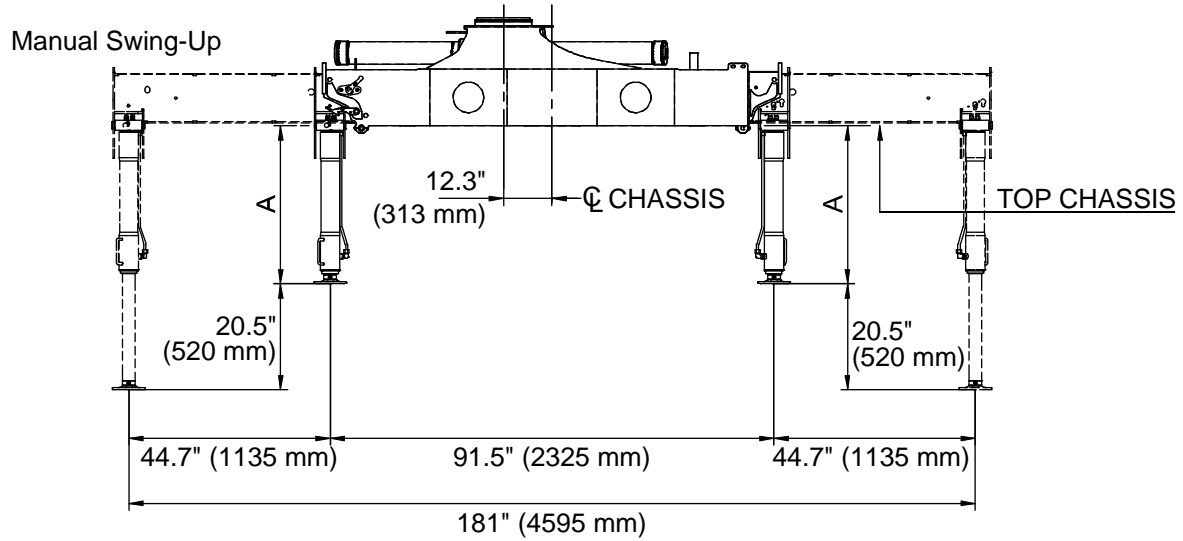

			
A	30.6" (777)	34.5" (877)	38.5" (977)



Swing-Up Stabilizer Legs





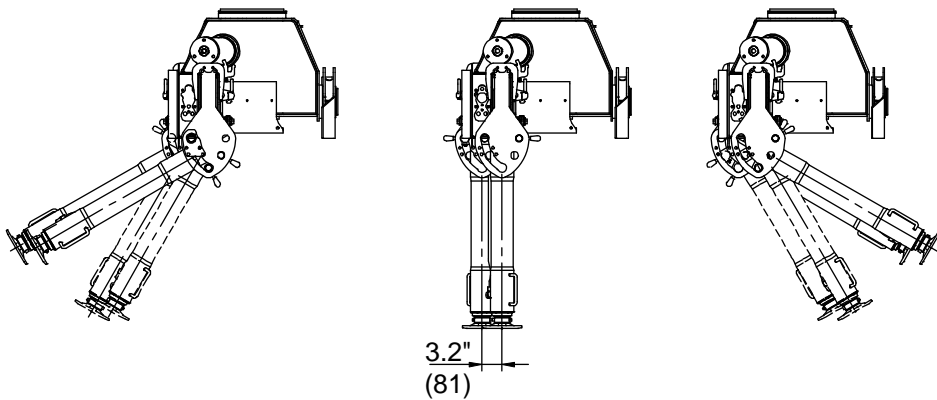
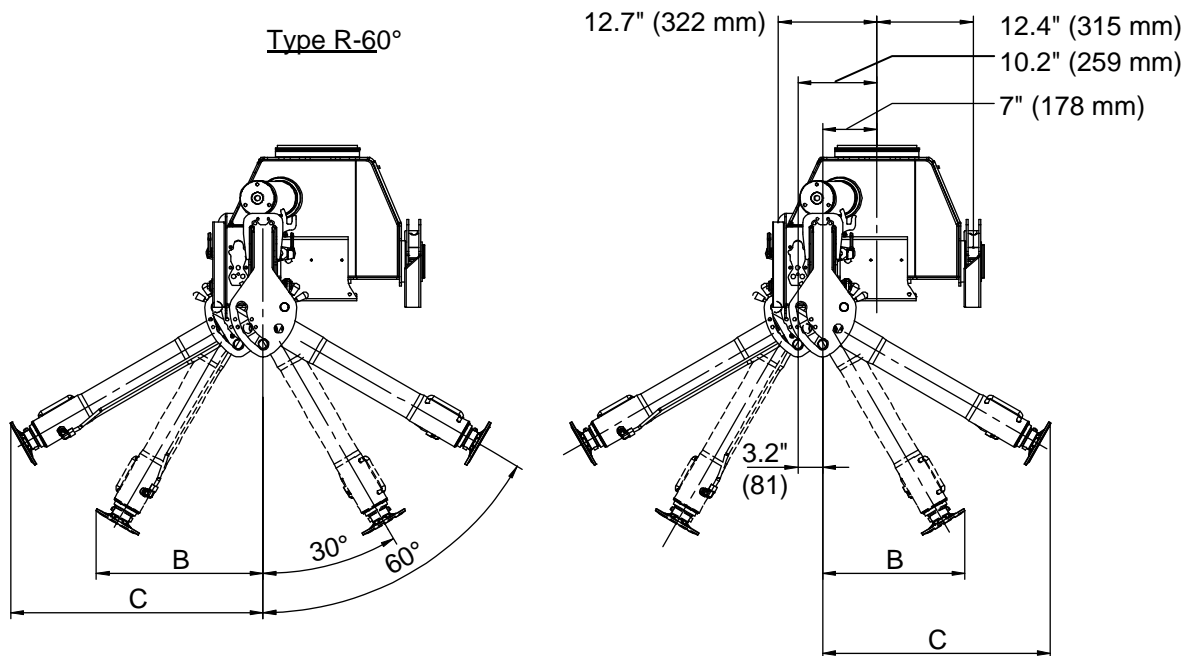

			
A	30.6" 775	34.5" 875	38.5" 975

Type R-60°

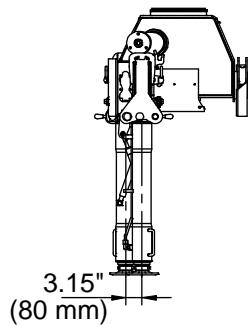
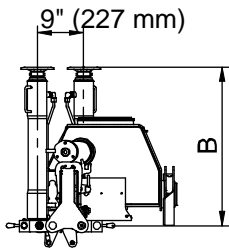
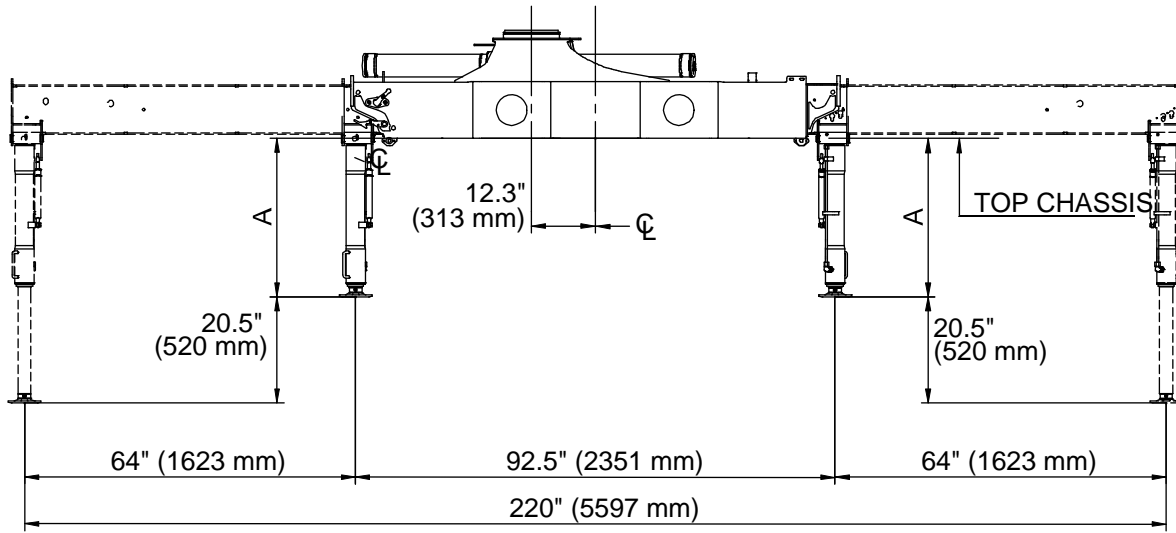
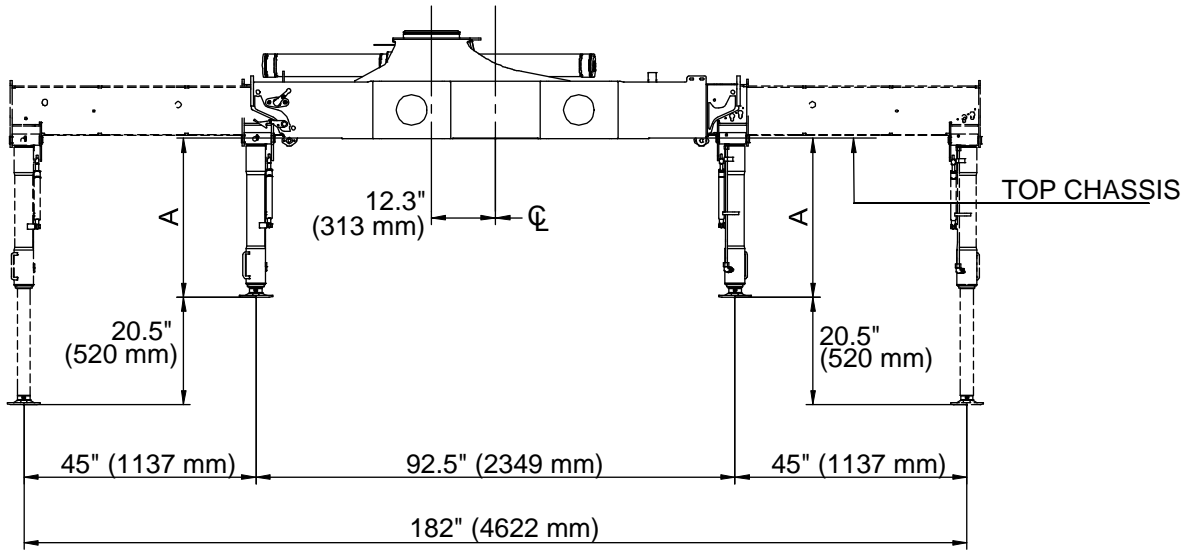

			
B	18.3" (465)	20.3" (515)	22.2" (565)
C	29.3" (745)	32.7" (831)	36.1" (918)



			
A	30.9" (785)	34.8" (885)	38.8" (985)
B	30.6" (775)	34.5" (875)	38.5" (975)

Swing Clearance Drawings

Single Link Swing Clearance

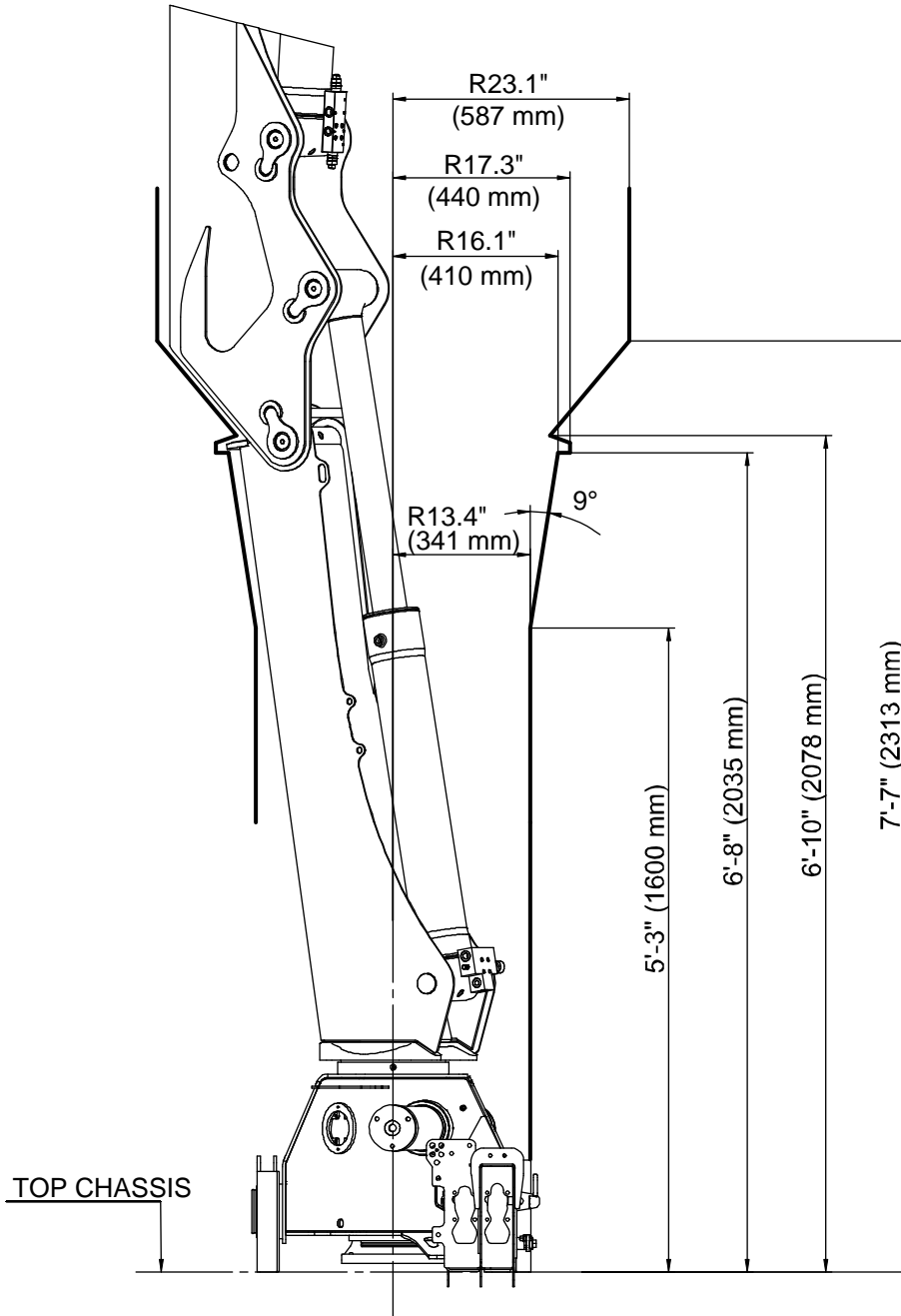

Double Link Swing Clearance

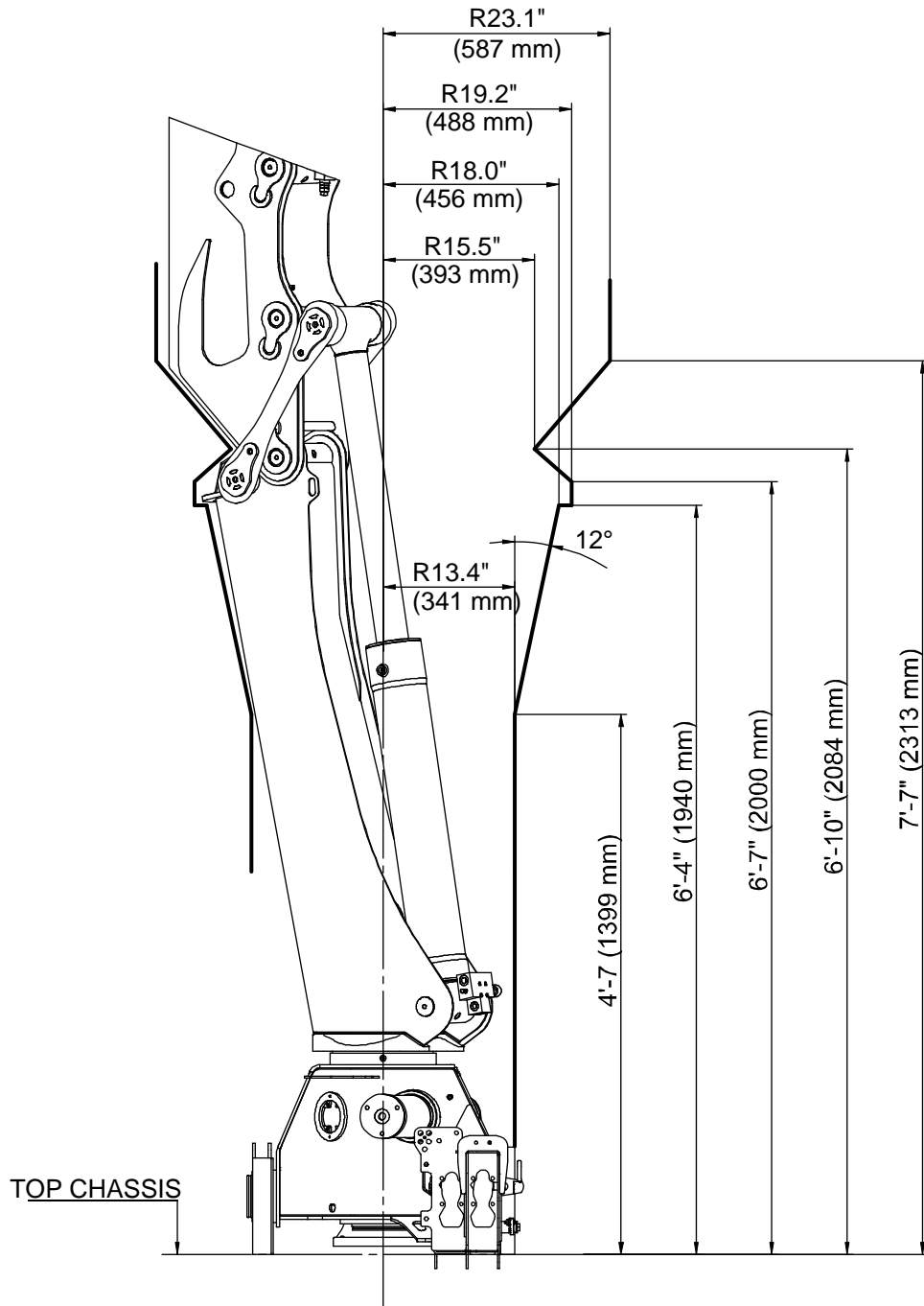

CHAPTER 2

Pressure Settings & Hydraulic Schematics

In This Chapter

Pressure Settings	25
Hydraulic Schematic.....	27

Pressure Settings

Working Pressure on Main-Relief Valve & Port-Relief Valves			
Function	Direction	Port	11/72 Pressure psi (bar)
Main-relief valve			4350 (300)
Slewing system	Right	A	P
	Left	B	P
Boom cylinder	Down	A	1450 (100)
	Up	B	4715 (325)
Jib cylinder	Up	A	4715 (325)
	Down	B	2900 (200)
Extension cylinders	Extend	A	P
	Retract	B	P
Rotator	Right	A	2900 (200)
	Left	B	2900 (200)
Grab	Open	A	2900 (200)
	Close	B	2900 (200)
Separate stabilizer valve		All	2175 (150)

Working Pressure on Load-Holding Valves			
Function	Direction	Port	Opening Pressure psi (bar)
Boom cylinder			4715 (325)
Jib cylinder	Up	A	4785 (330)
	Down	B	
Slewing system			3045 (210)
Extension cylinders	Extend	A	3045 (210)
	Retract	B	6235 (430)

Pressure Setting for Load Moment Limitation (LMB)	
Load moment limitation (LMB)	4205 (290)
Maximum Pump Performance	
Pump performance, 1-circuit	10.5 gpm (40 l/min)

Hydraulic Schematic

