

**DTAXS-39/42/44**  
**STEEL BOOM, NON-INSULATED BOOM,**  
**ARTICULATED TELESCOPIC AERIAL LIFT**

<b>GENERAL DATA:</b>	<b>DTAXS-39</b>	<b>DTAXS-42</b>	<b>DTAXS-44</b>
Working Height, Minimum	44'	47'	49'
Max. Horizontal Reach (Rotated to end)	28'	28'	30'
Approx. Stowed Travel Height	10'	10'	10'
Extension Boom Travel	108"	108"	120"
Main Boom Travel	-25°to+78°	-25°to+78°	-25°to+78°
Articulated Boom Travel	-2°to+80°	-2°to+80°	-2°to+80°
Basket Capacity	350 lbs	*350 lbs	*350 lbs
Installed Weight (approx.)	2450 lbs	2650 lbs.	2800 lbs
Chassis Requirement w/ Torsion Bar	15,000 GVW	15,000 GVW	19,000 GVW
Chassis Cab to Axle Requirement	60" to 84"	60"	84"

\*Minimum chassis GVWR listed requires use of outriggers to pass Stability Test.

**STANDARD FEATURES**

1. 24" X 24" X 42" Fiberglass Basket with Side Opening.
2. Rubber Boom Support
3. Steel Extension Boom.
4. 10 Gallon Oil Tank with Sight Gauge.
5. Shearball Rotation Gear.
6. Proportional Hydraulic Upper Controls and Lower Override Controls.
7. Two Maintenance/Operators Manuals.
8. 18" X 20" Pedestal.
9. Safety Harness and Lanyard.
10. 370° Non-Continuous Rotation.
11. Gate Valve in Suction Line.
12. 10 Micron Filter in Return Line.
13. Boom Tie-Down.
14. Epoxy Primer with White Finish Color.
15. Hydraulically Leveled Basket with Stow at Upper Controls.
16. Four Feathering Control Levers on Upper Control with Selector Valve.
17. Four Feathering Control Levers on Lower Control w/Upper Control Override.
18. 180° Hydraulically Actuated Basket Rotator.
19. Open Center Hydraulic System.
20. 2 Year Parts and Labor Warranty.
21. 110 Volt Outlet at Basket.
21. Non-relube, Maintenance-Free Bushings.
22. Engine Start/Stop from Basket.
23. 5 GPM Required Pump NOT INCLUDED.

**NOTE:** For D.C. Backup, Torsion Bar, Throttle Advance, and Other Options - See Options Page.

DUR-A-LIFT INC.  
P.O. BOX 31  
GEORGE, IOWA 51237  
PHONE NO: (712) 475-2804  
FAX NO: (712) 475-2809

EFFECTIVE DATE: July 1, 2011

DTAXS-1.0

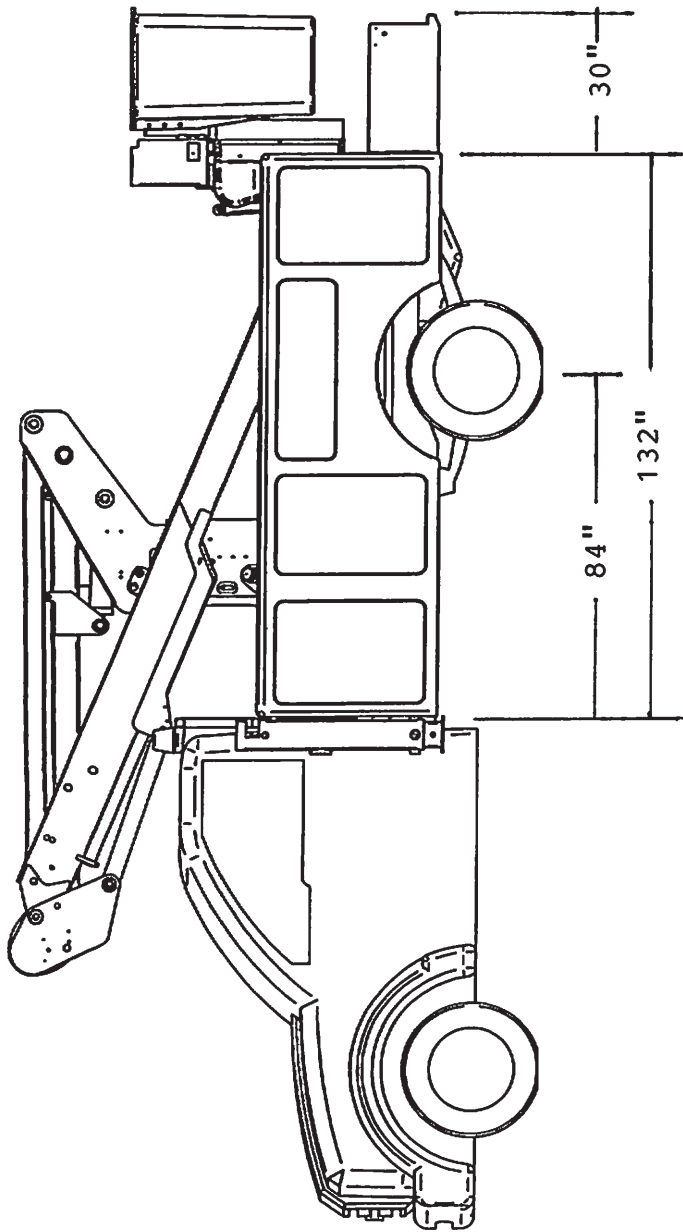
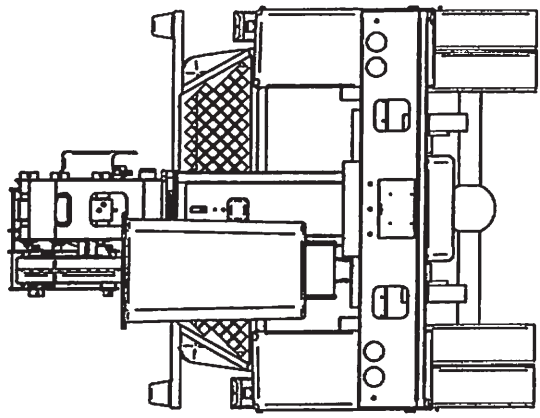

DTAX-44