

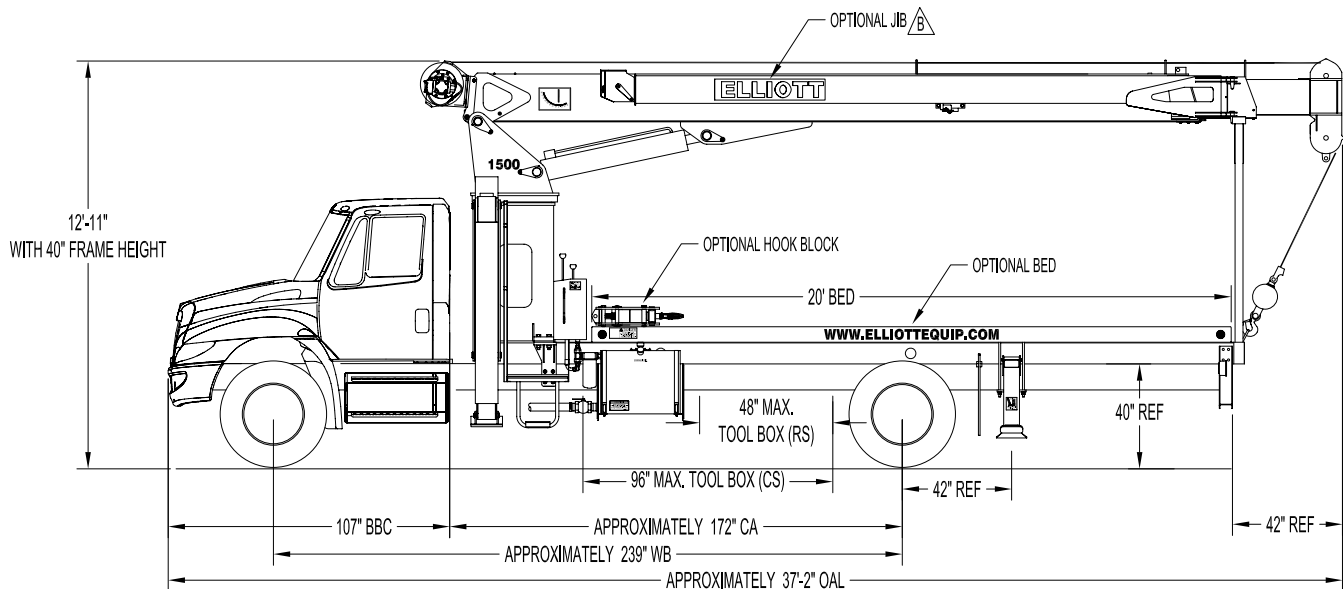

### 1560F SIDE VIEW DIAGRAM



- |                                 |                                     |                                 |                       |
|---------------------------------|-------------------------------------|---------------------------------|-----------------------|
| • <b>Maximum Vertical Reach</b> | 70'/21.3 m                          | • <b>Powered Boom Sections</b>  | 3                     |
| • <b>Working Area</b>           | 180 Degrees Standard (360 Optional) | • <b>Overall Height</b>         | 12'11"/3.9 m          |
| • <b>Lifting Capacity</b>       | 30,000 lbs/13,608 kg                | • <b>Operator Controls</b>      | Dual Operator Standup |
| • <b>Boom Length</b>            | 60'/18.3 m                          | • <b>Outrigger Type Front</b>   | A-Frame               |
| • <b>Crane Weight (Dry)</b>     | 14,825 lbs/6,725 kg                 | • <b>Outrigger Spread Front</b> | 20'10"/6.3 m          |
| • <b>Jib Lengths</b>            | 20'/6.1 m                           | • <b>Outrigger Type Rear</b>    | A-Underslung          |
| • <b>Winch Bare Drum Pull</b>   | 12,800 lbs/5,806 kg                 | • <b>Outrigger Spread Rear</b>  | 10'4"/3.1 m           |

## TECHNICAL SPECIFICATIONS

**Crane Capacity:** 30,000 lbs at five feet load radius.

**Maximum Tip Height:** 70' height (90' with optional 20' jib)

**Control Console:** Dual operator standup control stations equipped with four single axis control levers for the main crane controls. Operator station includes bubble level gauge, engine start/stop switch, signal horn button, variable speed foot throttle, lifting capacity chart, range diagram chart, boom angle indicator, system pressure gauge, 12V DC power source, and cup holder. Outrigger lever controls at control consoles.

**Boom:** Three-section fully proportional, high strength steel plated rectangular tube sections. A maximum boom tip height of 70' mounted on a truck. The boom nose contains one floating upper sheave and three lower sheaves. Assembly includes heavy-duty cylinder fittings, pivot pins, and replaceable wear pads.

**Winch:** Mounted at the base of the boom for a long fleet angle and flat level spooling of cable. Winch is driven by a planetary reducer and powered by a hydraulic motor. Burst-of-speed winch provides increased line speed. The winch brake is spring applied, pressure release design. Supplied with 275' of 9/16" wire rope with a single line pull of 9,600 pounds, and a downhaul ball with swivel hook for single part line.

**Load Moment Indicator System:** System senses hoist cylinder pressures, boom length and boom angle with hydraulic function lockout. The display console is equipped with a bar graph showing crane utilization, boom angle or boom length, a mode select controls for main boom and jib operation, and an anti-two block with an audio/visual warning and shut-off functions to limit hook-boom point contact.

**Outriggers:** One set of "A" Frame

main outriggers with 20'10" span, and one set of underslung "A" auxiliary outriggers with a 10'4" span.

**Frame:** Full length, all welded rigid 4-plate design sub-frame. Sub-frame allows for bolt-on addition of 18' bed.

**Turret:** Reverse offset turret is one-piece weldment. Turret rotates on large diameter ball bearing.

**Rotation:** Hydraulic motor drives turret through double reduction planetary swing drive for 372-degree non-continuous rotation. The swing drive system has a spring applied, pressure release brake.

**Lift:** One double-acting long stroke cylinder provides smooth and stable boom elevation. Holding valve prevents boom from falling in event of hose failure.

**Boom Extension:** Incorporates a single-stage hydraulic extension cylinder, attached to the largest boom section, with a proportional cable extension system driving the outermost section.

**Hoses:** All high pressure hoses are wire braid reinforced with a minimum safety factor of 4 to 1.

**Cylinders:** All cylinders use microhoned cylinder tubing, chrome shafts, top grade packing and protective rod wipers. Cylinder-mounted holding valves provided on all load-holding cylinders.

**Hydraulic System:** Equipped with cable-shift PTO, three-section gear pump, SAE O-ring face seals on pressure lines, and a 10-micron return line filter. The control valve distributes all flow to hoist system, swing circuit, and other crane functions. System is open center type.

**Oil Tank Capacity:** 70 gallon mounted to truck frame on roadside.

**Cab Equipment:** PTO cable with indicator lights installed in truck cab. U/L approved 5:BC dry chemical fire extinguisher installed in truck cab.

**Operators Manual & Video:** Two CD copies and one hard copy of operation, maintenance, safety and parts manual provided with each unit. Operational and safety video provided at delivery.

**Installation:** Unit installed on chassis, painted, system and tank filled with oil, tested, inspected, and ready to operate.

**Standard Paint:** Paint turret and boom white, outriggers red, and bed and boxes black.

**Bumper:** Bureau of Motor Carrier Safety rear bumper.

**Weight:** Approximately 14,825 lbs. with 18' steel-floor bed less truck.

**Truck Chassis Required:** Approx. 169" C.A. RBM 1,463,000 in-lb. per rail, 13,000 lb. front axle and 33,000 lb. GVWR required. Trucks must have front frame extension, 12V electrical system with high capacity alternator, cab clearance stop/tail/backup lights, and I.D. lamps. Recommended GVWR is minimum for BOOMTRUCK with flatbed only. Contact factory when additional equipment is to be added.

**Options:**

Computerized Load Moment Indicator System (LMI).

20' Fixed Jib.

Radio Remote Controls.

Superlink Short Jack Outriggers.

Gravity Leveled Steel Basket.

Front Jack for 360 Degree Area of Operation.

Hydraulic Tool Circuits on Bed.

Much more...

Elliott Equipment Company reserves the right to change the specification of any unit at any time without prior notice. This brochure is only a statement of general specifications on the date of this publication. For more detailed info on specific Elliott trucks go to [www.elliottequip.com](http://www.elliottequip.com)

**MAXIMUM LIFTING CAPABILITIES**



**MODEL 1500 60-ft BOOM**

**MAIN BOOM LOAD RATINGS WITH FULLY EXTENDED OUTRIGGERS**

**MAIN BOOM LOAD RATINGS**

LOAD RATINGS IN LBS. WITH OUTRIGGERS AND STABILIZERS EXTENDED

LOAD RADIUS (feet)	LOADED BOOM ANGLE	24 ft		A 33 ft		B 42		C 51 ft		D 60 ft	
		LOADED BOOM ANGLE		LOADED BOOM ANGLE		LOADED BOOM ANGLE		LOADED BOOM ANGLE		LOADED BOOM ANGLE	
5	76	30,000									
10	63	18,400	71	17,700	75	17,000	78	15,800			
15	48	13,800	61	12,800	68	12,300	73	11,600	75	11,400	
20	27	10,700	52	10,100	61	9,600	67	9,100	70	8,800	
25			39	8,300	53	7,900	60	7,400	65	7,200	
30			21	6,600	43	6,600	53	6,300	60	6,000	
35					32	5,500	46	5,400	54	5,200	
40					13	4,100	37	4,600	48	4,500	
45							26	3,750	41	3,500	
50									32	3,050	
55									27	2,600	
	0	7,100	0	4,650	0	3,250	0	2,350	0	1,750	
		350		250		200		150		150	

**JIB LOAD RATINGS**

LOAD RATINGS IN LBS. WITH OUTRIGGERS AND STABILIZERS EXTENDED

**20-FT FIXED LENGTH JIB**

LOADED BOOM ANGLE	20-FT JIB
78	4,700
74	3,700
70.5	3,000
66.5	2,400
62.5	2,100
58.5	1,700
54	1,400
49.5	1,300
45	1,200
39.5	1,000
33.5	800

DEDUCTIONS FOR STOWED FIXED LENGTH JIB

**NOTICE**

- DO NOT DEADHEAD LINE BLOCK AGAINST BOOM TIP WHEN EXTENDING BOOM

- KEEP AT LEAST 5 WRAPS OF LOADLINE ON THE WINCH DRUM AT ALL TIMES

- USE ONLY 9/16" DIAMETER WIRE ROPE, AS SPECIFIED BELOW, WITH THE PROPER BREAKING STRENGTHS LISTED

- ANTI-TWO-BLOCK SYSTEM MUST BE IN GOOD OPERATING CONDITION BEFORE OPERATING CRANE. SEE OPERATION & SAFETY MANUAL

1-PART LINE



2-PART LINE



3-PART LINE



4-PART LINE



ELLIOTT EQUIPMENT CO. SUPPLIED LOADLINE EQUIPMENT DEDUCTIONS:  
 DOWNHAUL WEIGHT.....180 lbs  
 ONE SHEAVE BLOCK.....375 lbs  
 TWO SHEAVE BLOCK.....640 lbs

MAX PULL: 9,600 lbs	19,200 lbs	28,800 lbs	30,000 lbs	9/16" - 6X37 IWRC (3.5:1 S.F.) 33,600-lbs. BREAKING STRENGTH
MAX PULL: 9,060 lbs	18,120 lbs	27,180 lbs	30,000 lbs	9/16" - SPIN RESISTANT (5:1 S.F.) 45,300-lbs. BREAKING STRENGTH
MAX PULL: 7,680 lbs	15,360 lbs	23,040 lbs	30,000 lbs	9/16" - SPIN RESISTANT (5:1 S.F.) 38,400-lbs. BREAKING STRENGTH

CRANE MEETS ASME B30.1 REQUIREMENTS AT TIME OF MANUFACTURE

DO NOT PAINT OVER ANY LABELS 110340 06007



Elliott Equipment Company Phone: 402-592-4500  
 4427 South 76th Circle Fax: 402-592-4553  
 Omaha, NE 68127 Email: sales@elliottequip.com

**Built for You.**  
[www.elliottequip.com](http://www.elliottequip.com)

**MAXIMUM RANGE CAPABILITIES**



**MODEL 1500 60-ft BOOM**

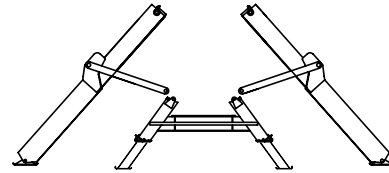
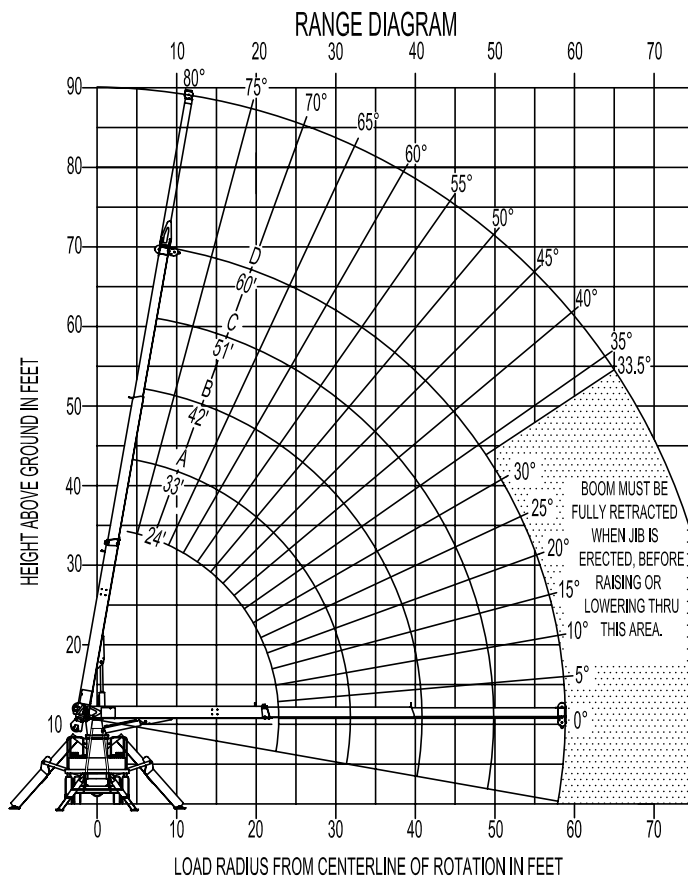

OUTRIGGERS AT FULL EXTENSION

**NOTE:**

1. Operate jib by radius when main boom is full extended. Increase boom angle if necessary to maintain load radius.
2. When boom is retracted, operate jib by boom angles. Do not exceed any rated jib capacities at reduced boom lengths.
3. Capacities do not exceed 85% stability.
4. Load ratings above bold line are structurally limited.
5. Personnel handling is allowed only with full span outriggers.
6. Boom load ratings are based on loaded boom radius. Loaded boom angles are given as reference only.

**AREA OF OPERATION**

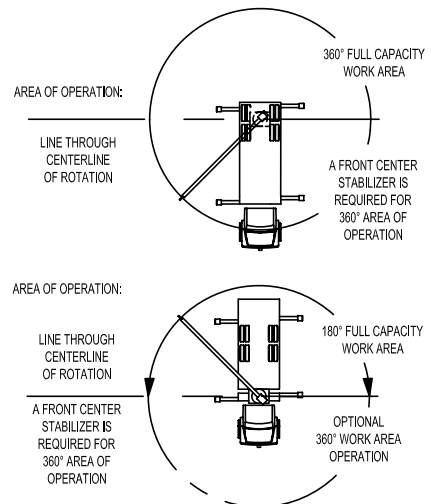

CRANE MEETS ASME B30.1 REQUIREMENTS AT TIME OF MANUFACTURE

DO NOT PAINT OVER HWY LABELS 110340 08907



Elliott Equipment Company  
 4427 South 76th Circle  
 Omaha, NE 68127  
 Phone: 402-592-4500  
 Fax: 402-592-4553  
 Email: sales@elliottequip.com

**Built for You.**  
[www.elliottequip.com](http://www.elliottequip.com)

## CHASSIS SPECIFICATIONS

	1560F BoomTruck
Wheelbase (WB)	236" / 599 cm
Cab to Axle (CA)	169" / 429 cm
Cab to End of Frame (EOF)	295" / 749 cm
Frame Section Modulus	13.3 in3-110,000 psi / 758,428 kPa
Front Axle Gross Weight Rating	13,000 lb / 5,896 kg
Rear Axle Gross Weight Rating	20,000 lb / 9,072 kg
Integral Front Frame Rails	Required for Front Stabilizer

Chassis data is minimum general requirements-not for engineering.  
 Actual dimensions and truck data will depend on truck selection and axle configuration.  
 \*Minimum chassis weight is required to meet 85% stability requirements.

## OPTIONS



### Radio Remote Control

Interference protected radio remotes let you get closer to your work and have full control over your machine.



### Pin-On Jib Attachment

One piece fixed jib that stows on the side of the boom and pins on the boom tip for easy placement while on the worksite.



### Continuous Boom Rotation

Add the convenience of 360 degree area of operation by adding a special boom rotation bearing for swinging without stops.



### Superlink Short Jack Outriggers

Reduce your outrigger spread with Elliott's patented Superlink outriggers that allow straight down outrigger deployment on one side and full crane operation on the other.



### Tool Boxes

Optional tool boxes and bed storage can accommodate any storage need for tools, work materials and more.

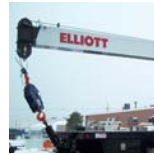

### Hook Block for Multi-Part Line

Elliott can install a 2-3 part hook block or a 4 part-hook block to improve lifting capabilities. The block can be stored at the rear of the bed.



### Gravity Levelled Basket

Elliott's pin-on work platform pins onto the boom for easy installation and removal. Gravity leveling and mechanical rotation makes it a great accessory for any worksite.



### Body Mounted Hose Reels and Circuits

Let us work with you to customize your tool compatibility by adding hose reels or hydraulic circuits to the crane bed.