

General Specifications

Link-Belt®

M 46

Eighty Series Hydraulic Rough Terrain Crane

HSP-8040 40-ton (36.29 metric ton)

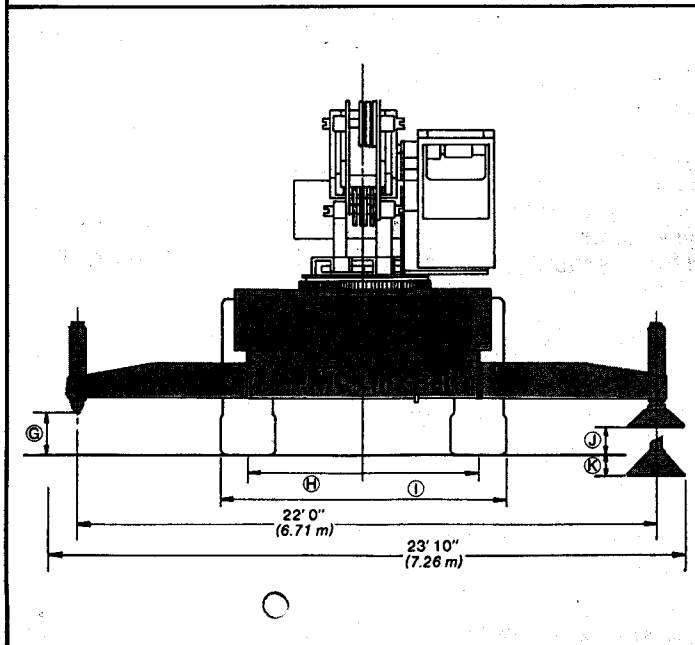
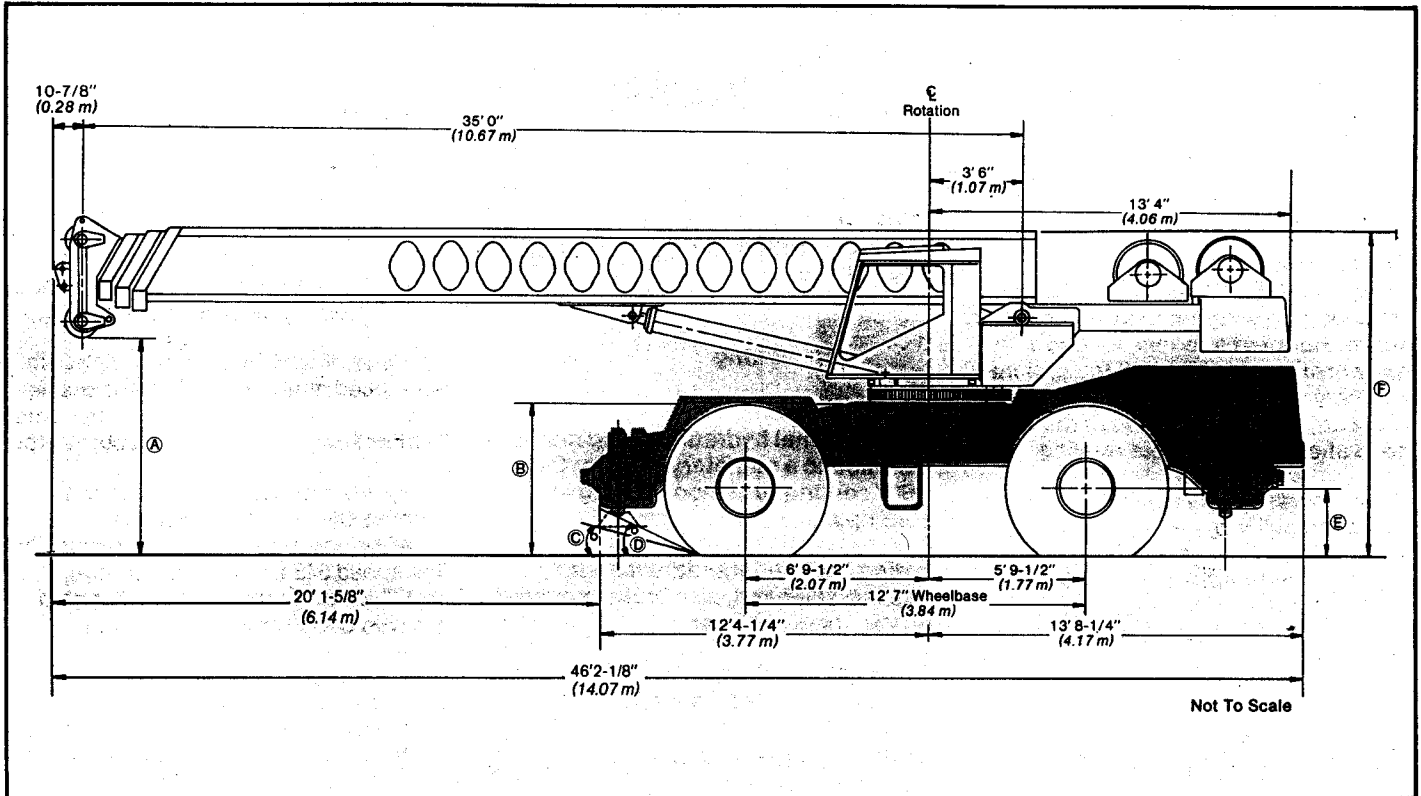

General dimensions	Feet	meters
Turning radius (4-wheel steer)	22' 0"	6.71
Tailswing of counterweight	13' 7-3/16"	4.14

Dimensions affected by tires

Tires	21.0 x 25 (24-PR)		26.5 x 25 (26-PR)	
	Feet	meters	Feet	meters
A	7'3-5/8"	2.23	7'2-7/8"	2.21
B	5'9-5/16"	1.76	5'8-1/2"	1.74
C	12°	—	11°	—
D	29°	—	28°	—
E	2'8-1/16"	.81	2'7-1/2"	.80
F	12'-1/4"	3.66	11'11-3/8"	3.65
G	1'9-7/8"	.56	1'9-1/6"	.53
H	7'8-5/8"	2.35	8'-3/8"	2.45
I	9'7-1/4"	2.93	10'5-1/4"	3.18
J	1'1-3/16"	.34	1'-3/8"	.32
K	5-1/4"	.13	6-3/16"	.16

Upperstructure



Boom

FMC patented design. 35' 0" - 110' 0" (10.67 - 33.53 m) four-section boom consisting of a base section, two power sections and a manual section. Boom side plates have diamond shaped impressions for superior strength-to-weight ratio and 100,000 p.s.i. (689.5 MPa) steel angle chords for lateral stiffness. Boom telescope sections are supported by wear shoes both vertically and horizontally.

Boom head — Four or five, 16-3/8" (0.42 m) root diameter head sheaves handle up to 10 parts of wire rope. Two easily removable wire rope guards; rope dead end lugs provided on each side of boom head.

Auxiliary lifting sheave — Optional. Single 16-3/8" (0.42 m) root diameter head sheave with removable wire rope guard, mounted to boom, for use with one or two parts of line off the optional auxiliary winch. Does not affect erection of fly or jib, or use of main head sheave for multiple reeving.

Boom elevation — Two FMC designed hydraulic cylinders with holding valves. Self-aligning steel bushings. Hand and optional foot controls for controlling 4-section boom elevation from -1° to 80°. Boom angle indicator standard.

Fly

Optional; 33' 0" (10.06 m) stowable one-piece lattice type.

Jib

Optional; 25' 0" (7.62 m) stowable A-frame. Can be offset 5°, 17.5°, and 30°. Attaches to fly only.



Cab and Controls

Environmental cab; isolated from vibration by rubber mounts. All tinted, tempered safety glass windows. Sliding rear window and swing up roof window for maximum visibility and ventilation. Slide-by door opens to 32" (0.81 m) width. 6-way adjustable operator's seat. 4-way adjustable tilt/telescoping steering wheel. Control levers for swing, boom telescope, winch and boom hoist with foot control swing brake. Outrigger controls, sight level bubble. Optional foot control for boom hoist.

Cab instrumentation — Dash mounted gauges for hydraulic oil temperature, converter temperature, fuel, water temperature, voltmeter, and oil pressure.



Swing

Bi-directional hydraulic swing motor mounted to a planetary reducer for 360° continuous smooth swing at 2.45 r.p.m.

Swing brake — Standard manually applied/released, disc brake mounted on the speed reducer.

Swing lock — Standard 360° position pin-type operated from operator's cab.

Counterweight — Bolted to upperstructure frame.



Hydraulic System

Main pump — Tandem, triple gear-type pump. Powered by torque converter through a pump disconnect. Pump disconnect is a jaw-type clutch engaged/disengaged from carrier.

Steering/outrigger pump — Single gear-type pump. Powered by torque converter through a straight mechanical drive. Pump operates at 2,700 p.s.i. (186.25 Bars).

Reservoir — FMC, 140 gallon (530.0 L) capacity. Diffusers for deaeration.

Filtration — One 2 micron filter, located inside of hydraulic reservoir. Accessible for easy replacement.

Control valves — 6 separate control valves allow simultaneous operation of all crane functions.



Load hoist system

Standard; Model 2M17 rear winch with two-speed motor and automatic brake; power up/power down mode of operation. Bi-directional gear-type hydraulic motor.

Optional; Model 2M17 front winch with two-speed motor and automatic brake; power up/power down mode of operation. Bi-directional gear-type hydraulic motor.

Line pulls and speeds — Maximum permissible line pull 14,430 lbs. (6 546 kg) and maximum permissible line speed 548 f.p.m. (167.03 m/min.) on 17" (0.43 m) root diameter standard grooved or optional smooth drum.

Optional upperstructure equipment Electronic boom length indicator, boom hoist foot control, propane heater, diesel heater, air conditioning, rear view mirrors, seat belt, warning horn, two-speed auxiliary winch, free fall on main winch, drum rotation indicators, 40-ton (36.29 metric ton) hook block, 8-1/2 ton (7.71 metric ton) hook ball and swivel, anti-two block, low oil pressure/high water temperature alarm, load moment device, back-up alarm, rear steer indicator, two single sealed beam head lights, front and rear directional signals, stop and tail lights, boom mounted working light.

Chassis



Type

FMC 9' 9" (2.97 m) wide, 151" (3.84 m) wheelbase.

4x4x4 - (4-wheel steer, 4-wheel drive) Standard; for rough terrain with limited turning area.

4x4x4 - (4-wheel steer, 4-wheel drive) Optional; no-spin differential on front axle; for rough terrain with limited turning area.

Frame — FMC designed, 100,000 p.s.i. (689.5 MPa) steel, double walled construction with integral 100,000 p.s.i. (689.5 MPa) steel outrigger boxes.



Outriggers

Four hydraulic, beam and jack outriggers. Vertical jack cylinders equipped with integral holding valve. Beams extend to 22' 0" (6.71 m) centerline-to-centerline and retract to within 9' 9" (2.97 m) overall width with floats stored. Equipped with stowable, lightweight 22" (0.56 m) diameter floats. Controls and sight level bubble located in upperstructure cab.



Axles

Front—Standard; heavy duty planetary drive/steer type.

Rear—Standard; heavy duty planetary drive/steer type.

Front—Optional; heavy duty no-spin differential, planetary drive/steer type.

Suspension

Front axle — Rigid mounted to frame.

Rear Axle — Pin-mounted on welded bronze bushings. Automatic hydraulic rear axle oscillation lockout engages when upperstructure rotates past 2-1/2° of centerline.

Tires

Front and rear — Standard 21.0 x 25 (24-PR) Earthmover type.

Optional — 26.5 x 25 (24 or 26 PR) Earthmover type.



Brakes

Service — Air over hydraulic brakes on all four wheels. Dual caliper disc type brakes. Disc diameter 18" (0.46 mm). Pad area 58.8 sq. in. (379.35 cm²) per caliper.

Parking/emergency — Disc, caliper type spring applied, hydraulic released; cab controlled; mounted on front axle.

Steering — Hydraulic two wheel, four wheel and "crab" steering.

Transmission — Clark 3-speed 2 range power shift transmission. 6-speeds available forward and 2-speeds reverse. Engine mounted torque converter.

Miscellaneous standard equipment Skid resistant finish on carrier deck, fenders, reflectors, access steps and grab handles, float storage compartment, automatic front axle disconnect, pump disconnect, hydraulic oil cooler.

Optional chassis equipment Towing shackles, hook block storage compartment, ether injector, alcohol evaporator, engine block heater, 24-volt start for G.M. engine, no-spin differential on front axle, spare tires and rims, pintle hook, jack cylinder hose covers, air dryer and emergency steering system.

Travel speeds and gradeability

Engine	Tires	Maximum Speed		Gradeability at stall	Maximum tractive effort at stall		Gradeability at 1.0 m.p.h. (1.61 km/h)	Maximum tractive effort at 1.0 m.p.h. (1.61 km/h)	
		m.p.h.	Km/h		Pounds	Kilograms		Pounds	Kilograms
GM 6V53N	21.0x25	21	33.79	110%	55,967	25 387	80.6%	48,030	21 786
	26.5x25	21	33.79	108%	55,422	25 139	79.3%	48,030	21 786
Cummins* V-555-C	21.0x25	21	33.79	110%	55,967	25 387	80.6%	48,030	21 786
	26.5x25	21	33.79	108%	55,422	25 139	79.3%	48,030	21 786

Engine	GM 6V53N	Cummins V-555-C*
Cylinders - cycle	6 - 2	8 - 4
Bore	3-7/8" (98.43 mm)	4-5/8" (117.47 mm)
Stroke	4-1/2" (114.30 mm)	4-1/8" (104.78 mm)
Displacement	318 cu.in. (5 211 cm ³)	555 cu.in. (9 095 cm ³)
Maximum brake h.p.	205 at 2,700 r.p.m.	201 at 2,700 r.p.m.
Peak torque	445 ft. lbs. (603.42 J)	414 ft. lbs. (561.38 J)
Electrical system	12 volt negative ground	12 volt negative ground
Fuel capacity	100 gallons (378.54 L)	100 gallons (378.54 L)
Alternator	42 amp	60 amp
Crankcase capacity	18.4 quarts (17.41 L)	24 quarts (22.71 L)
Air compressor	12 c.f.m. (0.34 m ³ /min)	13.2 c.f.m. (0.37 m ³ /min)

*Optional equipment



Axle loads 4-section boom

Base machine with standard 35' 0" - 110' (10.67 - 33.53 m) 4-section boom, 33' (10.06 m) lattice fly section, 600' (182.88 m) 3/4" (19 mm) wire rope, FMC 4 x 4 x 4 carrier with GM 6V-53N engine, 26.5 x 25 tires, counterweight.	G.V.W. ^①		Upper facing front				Upper facing rear			
			Front axle		Rear axle		Front axle		Rear axle	
	Lbs.	Kgs	Lbs.	Kgs	Lbs.	Kgs	Lbs.	Kgs	Lbs.	Kgs
	70,612	32,029	36,733	16,662	33,879	15,367	23,175	10,512	47,437	21,517
21.0 x 25 -tires	- 158	- 72	- 79	- 36	- 79	- 36	- 79	- 36	- 79	- 36
Hook block at bumper	+ 750	+340	+1,115	+506	-365	-166	-479	-217	+1,229	+557
Headache ball at bumper	+ 215	+ 98	+ 320	+145	-105	- 48	-137	- 62	+ 352	+160
Auxiliary lifting sheave	+ 130	+ 59	+ 400	+181	-270	-122	-280	-127	+ 410	+186
25' 0" (7.62 m) A-frame jib stowed	+1,128	+512	+1,440	+653	-312	-142	-402	-182	+1,530	+694

① Adjust gross vehicle weight and axle loading according to components weight.

We are constantly improving our products and therefore reserve the right to change designs and specifications.



FMC Corporation Construction Equipment Group Lexington Kentucky 40512

Link-Belt® cranes/excavators manufactured in: Cedar Rapids Iowa • Lexington & Bowling Green Kentucky • Ontario Canada • Milan Italy • Queretaro Mexico & Nagoya Japan (under license)