

# HiReach™ L60

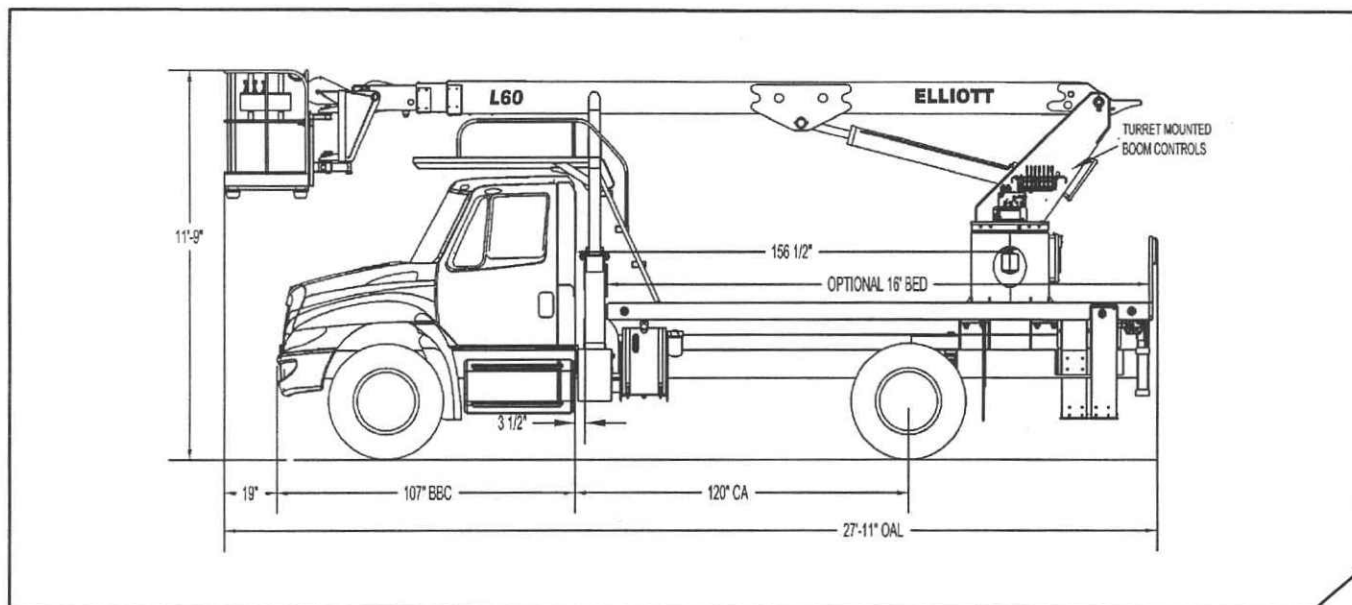

## GENERAL UNIT DESCRIPTION

**HiReach** – The machine that launched an industry, the wide-ranging Elliott HiReach telescoping aerial workplatforms and cranes allow you to do more with just a single machine. From material handling and digging to basic crane and boom, the HiReach does the work of a fleet of trucks. Available with heights ranging from 35 feet to 158 feet, the HiReach comes fully equipped with standard features that are sold as options by our competition. Only Elliott features full hydraulic extension with no cables and chains. Our extension cylinder arrangement gives you the smoothest, most precise ride in the industry. What's more, all of Elliott's products can be customized to create tailor-made machines that include special platform features, pressure washers, body and tool box packages and more,

Basic unit includes base assembly supporting rotating turret, hydraulically powered rotation mechanism, oil reservoir, oil, manual hydraulic controls mounted on turret and full pressure hydraulic single stick remote control. 48" x 24" molded bucket with 2 access steps. Telescopic articulated boom design and pump. ECA "A" type hydraulically powered, individually controlled main outriggers. Power take off and pump drive, pump. Holding valves on all cylinders, fire extinguisher, remote start /shutdown at upper and lower controls, 12 volt emergency pump with switch at upper and lower controls, back up alarm, PTO hour meter, (1) body harness. Paint Hi-Reach white. Unit certified to Ansi 92.2 for Vehicle-Mounted Elevating and Rotating Aerial Devices. Working height 46 ft. Platform capacity 350 lbs.

### Technical Specifications

**Minimum Platform Height:** 57' ground to platform floor.

**Working Range:** 62' max. height and 56' max. side reach.

**Work Platform:** 30" x 54" EZR work platform with 40" high rails. Equipped with two safety lanyard attachment loops and two safety harnesses and 72" lanyards. Platform capacity 500 Lbs.

**Platform Leveling System:** Hydraulic "closed" system consisting of twin platform cylinders interacting with a boom-actuated master cylinder mounted in boom support turret. System provided with factory-set relief valves to compensate for oil expansion or overload during platform leveling operation. Remote releveling controls provided in platform and at ground controls to give precise releveling capability.

**Platform Controls:** Three individual proportional electronic controllers meter pilot-operated, pressure-compensated modulating valves. Boom ground controls are mounted on roadside of turret. Remote controls for boom operations from platform operate from a removable remote control box. Hi/Lo range, start/stop and engine speed toggle controls are also located at platform. Electric remote control cable extends through the electrical slip ring to cable carrier on side of boom to extending boom sections.

**Lower Controls:** Mounted on roadside of turret.

**Outrigger Controls:** Parallel open-center stack valve for lever-operated control of right and left outriggers. The outrigger valves are mounted at the rear, under each corner of the bed with roadside valve controlling roadside outriggers and curbside valve controlling curbside outriggers.

**Outriggers:** "MH" out-and-down main outriggers with 18 ft. spread. "A" type secondary outriggers with 12-1/2 ft. spread.

**Frame:** One piece, all welded, box-type fabrication with integral outrigger mounts. Bolt-on torque frame distributes load to front of truck.

**Turret:** Reverse offset turret is one-piece weldment. Turret rotates on large diameter ball bearing.

**Rotation:** Continuous turret rotation with no stops. Hydraulic motor drives turret through self-locking gear box.

**Boom:** Steel rectangular tube sections with 1/4" wall thickness. Assembly includes heavy-duty cylinder fittings, pivot pins, and replaceable wear pads.

**Boom Extension:** One "Piggyback" internal cylinder extends the outer boom sections.

**Lift:** One double-acting 6" full displacement, long stroke cylinders provide smooth and stable boom elevation. Holding valve prevent boom from falling in event of hose failure.

**Cylinders:** All cylinders use microhoned cylinder tubing, chrome shafts, top grade packing and protective rod wipers. Cylinder-mounted holding valves provided on all load-holding cylinders.

**Hoses:** All high pressure hose is wire braid reinforced with a minimum safety factor of 4 to 1.

**Oil Tank Capacity:** 35 gallon mounted to truck frame on roadside.

**Hydraulic System:** Operating pressure approximately 2,500 PSI. System is parallel open center type and is equipped with liquid-filled pressure gauge. Oil is supplied to upper cylinders through hydraulic union in center of turret to cable carrier along side of the boom.

**Pump:** Gear type, direct mount to truck PTO. 14 GPM @ 2,500 PSI on high engine speed.

**PTO:** Heavy-duty, high-speed. Cable engaged from cab.

**Cab Equipment:** PTO cable with indicator lights installed in truck cab. Engine speed control and start/stop installed with control switches in platform remote control box and also located at lower controls. U/L approved 5:BC dry chemical fire extinguisher installed in truck cab.

**Operators Manual & Video:** Two copies of operation, maintenance, safety and parts manual provided with each unit. Operational and safety video provided at delivery.

**Installation:** Unit installed on customer's truck, painted, system and tank filled with oil, tested, inspected, certified and ready to operate.

**Standard Paint:** Paint Hi-Reach white, outriggers red, and bed and boxes black. Top of bed painted with black nonskid surface.

**Bumper:** Bureau of Motor Carrier Safety rear bumper.

**Weight:** Approximately 13,500 lbs. with 16' steel-floor bed less truck.

**Truck Chassis Required:** Approx. 120" C.A. RBM 900,000 in-lb. per rail, 8,500 lb. front axle and 26,000 lb. GVWR required. Trucks must have increased cooling, heavy-duty front and rear springs, 12V electrical system with high capacity alternator, cab clearance stop/tail/backup lights, and I.D. lamps. Additional equipment to consider: front tow hook, pintle hook, mud and snow tires for off highway use. Recommended GVWR is minimum for HI-REACH with flatbed only. Contact factory when additional equipment is to be added.

### Options

**Cab Guard:** Cab and windshield guard provided to allow for accessing to platform while boom is in boom rest.

**Bed:** Length 16' (other lengths available) Width 98" with 3/16" steel tread plate floor, 6" rub rail and heavy duty cross members. Stake pockets on both sides of bed. Spray suppressant splash guard installed. Chassis stop/turn/back-up lights remounted as necessary. Rear clearance and side market lights with reflectors on bed.

**Heavy-Duty Hydraulic Winch:** Mounted at the base of the boom for a long fleet angle and flat level spooling of cable. Heavy-duty winch supplied with 180 ft. of 3/8" diameter 6x37 IPS IWRC wire rope and swivel hook. Anti-2-block switch, 2-part hook, horn and certification to ANSI B 30.5 mobile cranes provided.

Platform Jib

Hydraulic, Air & 110V Lines to Platform

Welder Generators

Wood-Floor Bed

Line Bodies

Tool Storage

Full Cab Guard

Miscellaneous Options...Contact factory for details



4427 South 76th Circle

Omaha, NE 68127

Phone: 402-592-4500

Fax: 402-592-4553

Email: [info@elliottequip.com](mailto:info@elliottequip.com)

[www.elliottequip.com](http://www.elliottequip.com)

Notes:

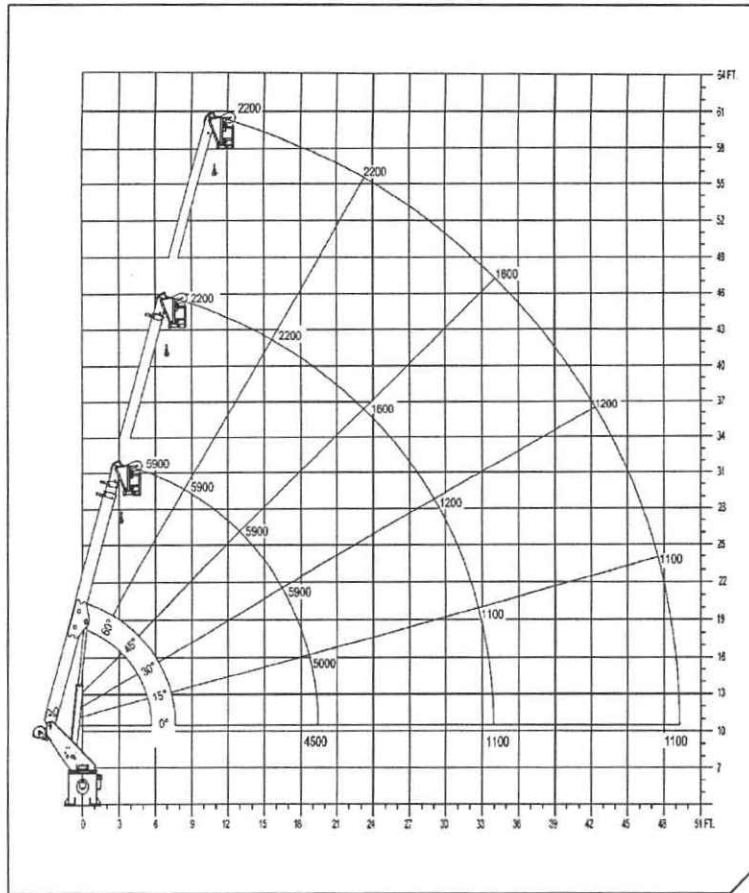

Notes:

**THIS AERIAL DEVICE IS NON-INSULATING. IT PROVIDES NO ELECTRICAL PROTECTION. CONTACT WITH OR INADEQUATE CLEARANCE TO AN ENERGIZED LINE OR APPARATUS IS AN ELECTROCUTION HAZARD.**

Elliott Equipment Company reserves the right to change the specification of any unit at any time without prior notice. This brochure is only a statement of general specifications on the date of this publication. For more detailed info on specific HiReach trucks go to [www.elliottequip.com](http://www.elliottequip.com)