

7/48

Articulating Crane



▶ 7/48 Articulating Crane

IMT® 7/48 articulating cranes can easily load and unload materials — even in tight spots and around obstacles — because they're compact and maneuverable. Featuring hexagonal booms for greater strength and stability, these cranes have a max capacity of 6120 lb (2775 kg) and a maximum horizontal reach of 34 ft 6 in (10.5 m). Plus, 7/48 articulating cranes can stow within themselves, freeing up payload space for additional materials — and they're available with innovative features and options that are designed to make your job easier and more productive.



7/48 Specifications

	1 - Hydraulic	2 - Hydraulic	3 - Hydraulic	4 - Hydraulic
Crane Rating*	48,460 ft-lb (6.7 tm)	47,015 ft-lb (6.5 tm)	45,570 ft-lb (6.3 tm)	44,120 ft-lb (6.1 tm)
Max Horizontal Reach	17' 1" (5.2 m)	23' (7 m)	28' 7" (8.7 m)	34' 5" (10.5 m)
Max Vertical Reach	23' 7" (7.2 m)	29' 6" (9 m)	35' 5" (10.8 m)	41' (12.5 m)
Max Capacity	4300 lb (1950 kg)	4080 lb (1850 kg)	3915 lb (1775 kg)	3695 lb (1675 kg)
Max Cap @ Max Reach	2920 lb (1325 kg)	2040 lb (925 kg)	1545 lb (700 kg)	1145 lb (520 kg)
Crane Weight **	1905 lb (865 kg)	2070 lb (940 kg)	2215 lb (1005 kg)	2350 lb (1065 kg)
Hook Approach				
Vertical	8' 2" (2.49 m)	7' 10" (2.39 m)	7' 6" (2.28 m)	7' 2" (2.18 m)
Horizontal	2' 9" (0.84 m)	2' 11" (0.89 m)	3' 1" (0.94 m)	3' 3" (1.0 m)
Center of Gravity - Stored				
Vertical	1' 11" (582 mm)	1' 11" (595 mm)	2' (605 mm)	2' (610 mm)
Horizontal (C/L Rotation to Bridge)	6.5" (165 mm)	6.6" (168 mm)	6.7" (170 mm)	6.8" (172 mm)

* Crane rating (ft-lb) is the rated load (lb) multiplied by the respective distance (ft) from centerline of rotation with all extensions retracted and the inner and outer booms in a horizontal position, per ANSI B30.22. ** Crane weight is for standard crane with tank & 8-bolt long mounting kit. Does not include stabilizers, tank or oil.

Standard Features

- Application-specific product offering
- Superior lift-to-weight ratio
- Long-reach capabilities
- Hexagonal booms for superior reach and maximum control
- Integrated hydraulic reservoir in crane base
- Powder coat paint

Options

- Radio remote control
- Boom tip functions for hydraulic attachments

Specifications

Stabilizer Pad Diameter	5.5" (140 mm)
Crane Storage Height	6' 3" (1895 mm)
Mounting Space	1' 11" (583 mm)
Rotational Torque	9945 ft-lb (1.4 tm)
Rotation	400°
Optimum Pump Performance	7.9 gpm (30 L/min)
System Pressure	3990 psi (275 bar)
Oil Reservoir Capacity	9.2 gal (35 L)
Stabilizer Extension Span	
Standard (manual out/hydraulic down) Weight	11' 2" (3400 mm) 275 lb (125 kg)
Option 1 (manual out/hydraulic down) Weight	15' 7" (4760 mm) 365 lb (165 kg)
Option 2 (manual out/hydraulic down swing-up stabilizer) Weight	18' 1" (5500 mm) 430 lb (195 kg)

Minimum Chassis Specifications

Front Axle Rating (GAWR)	6000 lb (2720 kg)
Rear Axle Rating (GAWR)	12,460 lb (5650 kg)
Resistance to Bending Moment Minimum	675,000 in-lb (77,770 kg-m)



Stabilizers

Operators can deploy stabilizers by manually pulling in and out while hydraulic controls move the stabilizers up and down to ensure safe lifting.



Hexagonal Boom Design

A hexagonal profile with large bearing surfaces ensures greater strength and stability for horizontal and vertical spans — even when working in extreme positions with long reaches. Plus, it's protected by powdercoat paint that never fades, flakes, or corrodes.

▶ 7/48 Capacity Charts

7/48 K1

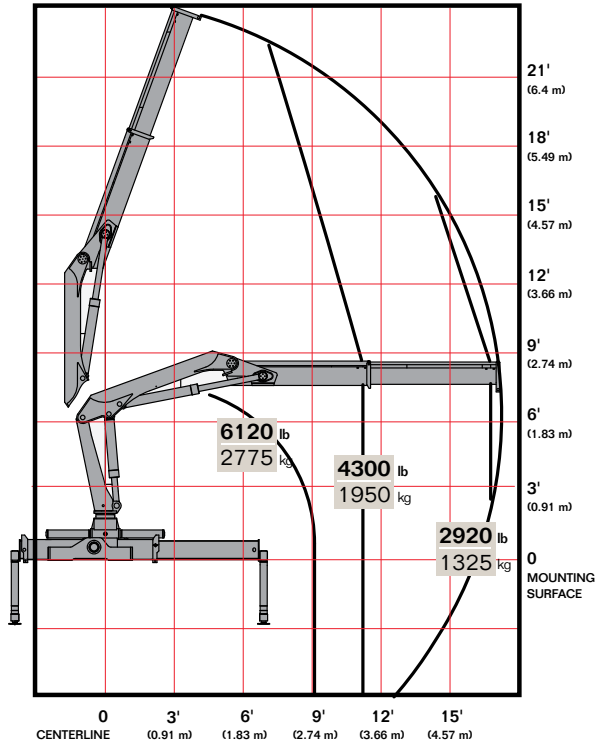

7/48 K2

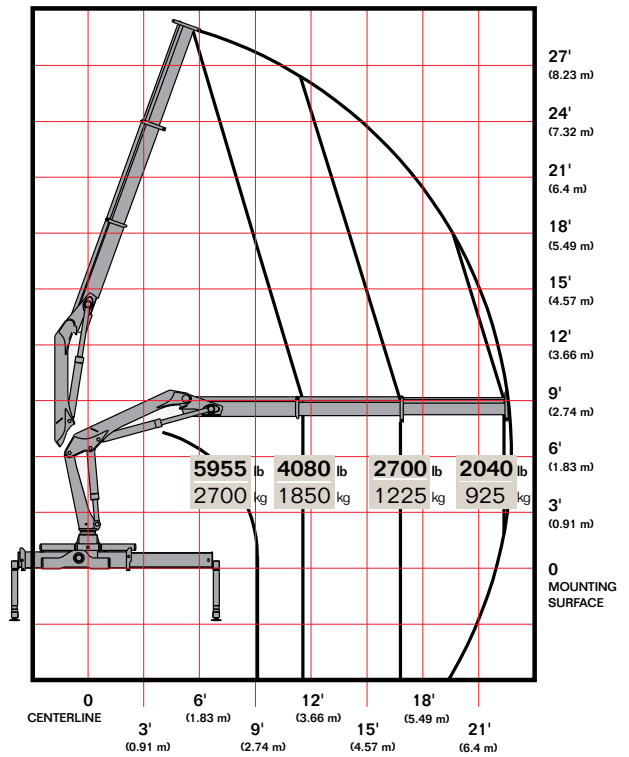

7/48 K3

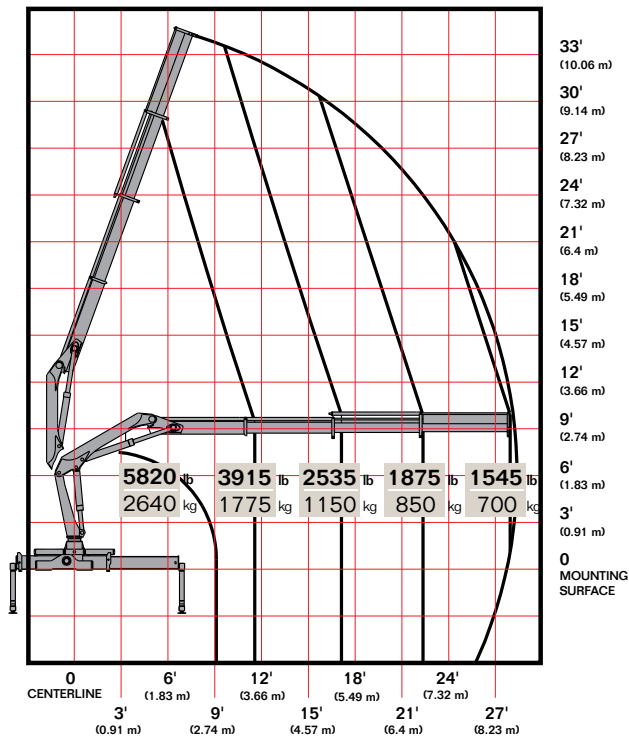

7/48 K4

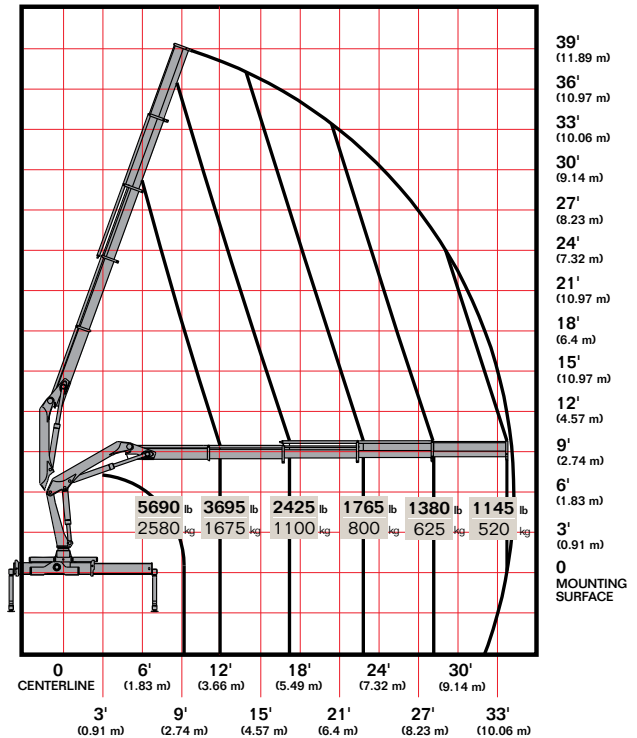

Limit working loads to those shown.
Deduct the weight of load-handling devices.

▶ 7/48 Lifting Capacity

7/48 - 1 Hydraulic

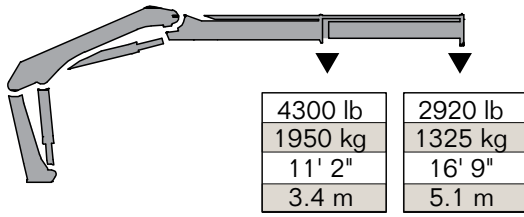

7/48 - 2 Hydraulic

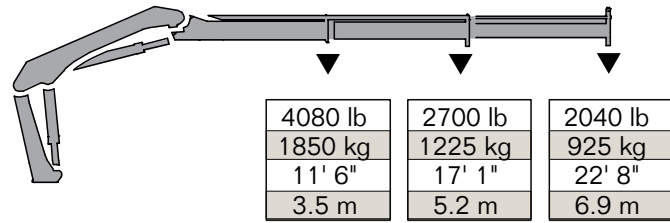

7/48 - 3 Hydraulic

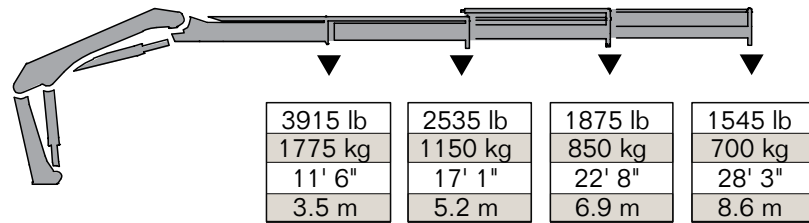

7/48 - 4 Hydraulic

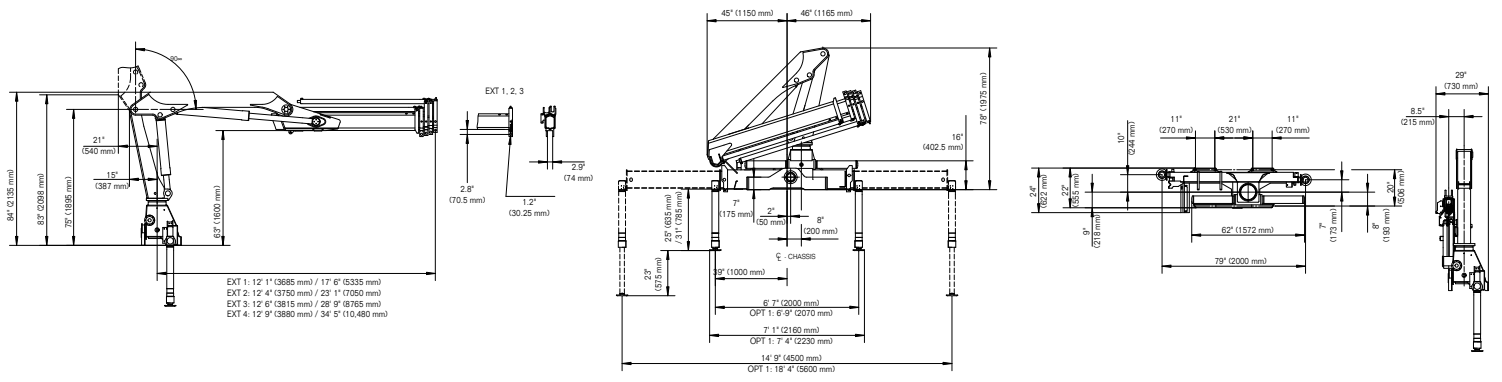
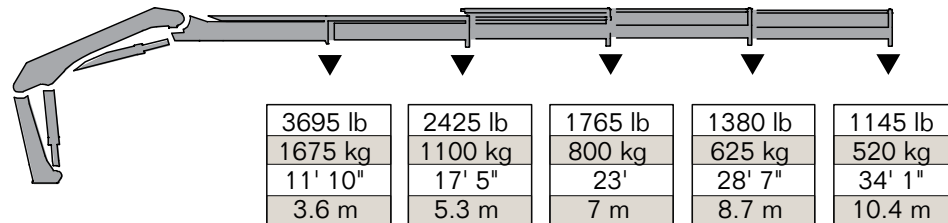

Power Source

- Standard integral-mounted piston hydraulic pump and PTO application

Cylinder Holding Valves

- Integral-mounted counterbalance valves or load-holding check valves
- Prevention of sudden cylinder collapse in case of hose failure

Rotation System

- 400 degree rack and pinion
- 9945 ft-lb (1.4 tm) rotational torque
- Counterbalance valve on each cylinder to stop motion in case of hose failure

Hydraulic System

- Open-centered system — closed optional
- Regeneration system on extension cylinder to ensure quick deployment
- Hydraulic oil reservoir, air breather, replaceable return-line filter, and control valve with levers

Overload System

- Load-limiting capability for boom functions
- Rated capacity limitation (RCL) 5300 blocks load-increasing functions when full capacity is attained



Nothing Says Commitment Like The Diamond.™

IMT has been meeting the needs of our customers for over 50 years and none of it would have been possible without a distributor network that's second to none. IMT distributors offer fast, knowledgeable service and the ability to help customers find the right product for every application. When you're looking for reliable equipment and dependable service, remember IMT.



An Oshkosh Corporation Company

Iowa Mold Tooling Co., Inc.
500 Highway 18 West
Garner, Iowa 50438
800-247-5958 • www.imt.com

IMT reserves the right to make changes in engineering, design, and specifications; add improvements; or discontinue manufacturing at any time without notice or obligation. IMT, the IMT logo and NOTHING SAYS COMMITMENT LIKE THE DIAMOND are registered trademarks or trademarks of Iowa Mold Tooling Co., Inc., Garner, IA, USA.
© 2013 Iowa Mold Tooling Co., Inc. All Rights Reserved.