

# TH460B

Telehandler

**CAT**®



**Stage II Compliant**

Cat® 3054E Electronic Engine

Gross Power	74.5 kW/99.9 hp
Operating Weight	10 500 kg
Rated Load Capacity	4000 kg
Maximum Lift Height	13 500 mm

## TH460B Telehandler

*Caterpillar Telehandlers offer performance and versatility.*

---

### Operator Station

- ✓ Operators will feel relaxed and comfortable in the spacious, ergonomically designed cab.

Considerable attention has been paid to control layout, making this cab an industry leader. **pg. 4**

---

### Ease of Operation

- ✓ Ease of operation was paramount in the design of the new TH460B. The single joystick, with its intuitive, modulated, hydraulic functions and the new Cat® electronic machine information display are designed to maximize operator efficiency. **pg. 5**

---

### Performance

- ✓ In its size class, the TH460B combines productivity, maneuverability and responsiveness to deliver smooth and stable performance on the job site. **pg. 6**

*The TH460B is a highly versatile machine, designed to deliver maximum performance with traditional Cat reliability, durability and productivity in the toughest working conditions.*



- ✓ *New features*



---

### Powertrain

- ✓ The TH460B is designed to perform in the toughest conditions. With its Caterpillar 3054E engine and purpose designed Caterpillar transmission and axles, you can depend on the TH460B to keep your job on schedule. **pg. 7**

---

### Versatility

- ✓ The TH460B is a very versatile machine. With its hydraulic quick coupler and extensive range of work tools, you can simply and efficiently get the job done. **pg. 8**

---

### Cost of Ownership

- ✓ Extended service intervals and the reduction in service parts give Cat the lowest operating costs in the industry. **pg. 9**

---

### Serviceability and Customer Support

- ✓ The lowest operating costs in the industry – setting new standards in serviceability.

Caterpillar Dealer Services enables you to operate longer with lower costs, helped by significantly extended service intervals. **pg. 10**



## Operator Station

*The operator station provides comfort and protection with excellent job site visibility and convenient, logical controls.*



**Intuitive Control Layout.** All day operator comfort and efficiency is ensured through our simple, logical control layout.

**Electronic Machine Information Display.** Communicates essential technical data to facilitate easier machine operation.

**Joystick.** The joystick is capable of three simultaneous boom functions making machine operation easy. All functions are fully modulated.

**Easy Access.** Cab entry and exit is both easy and safe due to the well placed handholds and step.

**Operator Protection.** The machine provides full operator security with ROPS/FOPS protection.

**Seat.** A variety of seats are available, tailored to meet the requirements of the operator and applications.



**Excellent Visibility.** The B Series cab has superb visibility due to the use of advanced virtual design techniques.

## Ease of Operation

*Ease of operation was paramount in the design of the new TH460B. The single joystick, with its intuitive, modulated, hydraulic functions and the new Cat electronic machine information display are designed to maximize operator efficiency.*



**Joystick Control.** The joystick allows three simultaneous boom functions and incorporates a unique slider switch. Two joystick control patterns are available to meet application requirements. The joystick also operates the auxiliary hydraulic function and allows the option of a second auxiliary service for the use of work tools that require more than one hydraulic service.

**Hydraulic System.** The Cat Electro Hydraulic system allows all three boom functions to be operated simultaneously and proportionally. This enables precise placing of loads in challenging applications. Auxiliary hydraulic functions are available on the joystick to allow operators to utilize more complex work tools. A continuous flow auxiliary hydraulic supply is also available for operating tools such as pickup brooms.

**Integrated System.** Cat's exclusive integrated management system allows the engine, transmission and hydraulic systems to operate with maximum efficiency, control and productivity.

**Flow Sharing.** Three simultaneous hydraulic functions are achieved using a flow sharing hydraulic valve. A load sensing variable displacement pump allows full hydraulic power even at low revs.



## Performance

*The TH460B delivers high performance to meet your specific job site needs.*



**Lift Height.** The TH460B can effectively and quickly place bricks, roofing materials and trusses to a maximum height of 13 500 mm.

**Reach.** Job site obstacles present challenges demanding a machine to place loads at greater distances – the TH460B delivers.

**Maneuverability.** The TH460B offers excellent maneuverability, due to its tight turning circle and its three different steering modes. The TH460B has 48 degree axle steering angle and no rear tail swing, allowing it to work productively and safely in confined areas.

**Steering Modes.** The TH460B offers three steering modes (two wheel, crab and circle steer) to allow an operator to easily position the machine. Steering modes are selected by a single 3-position rocker switch.



## Powertrain

*Caterpillar engines, axles and transmissions give you the quality powertrain that you expect.*



**High Torque Rise Engine.** The Cat 3054E electronic engine is fully compliant with the latest round of worldwide emissions regulations. While continuing to deliver maximum performance, it features improved timing, reduced smoke and exceptional service improvements. For improved sound characteristics, a venturi tailpipe has been packaged inside the engine enclosure. Electronic engines deliver:

- Improved low idle performance
- Product Link capabilities
- Improved fuel consumption
- Improved cold start
- Increased diagnostic and security capability

**Cooling System.** The cooling system has been designed to work in the most challenging conditions.

**Transmission.** The B-Series has a purpose designed Cat transmission. The TH460B has four speed forward/three speed reverse powersyncro transmission as standard.

**Axles.** The TH460B is fitted with Caterpillar planetary reduction axles, with four wheel braking. For improved machine performance in difficult conditions, a differential lock is included (front axle).



## Versatility

*Re-define the traditional role of a Telehandler with the Cat TH460B.*



**Hydraulic Services.** Machines are equipped with Auxiliary Hydraulic services, allowing the use of hydraulically operated work tools. 3 options are available:

- One auxiliary hydraulic service at the boom head
- Two auxiliary hydraulic services at the boom head
- Continuous Hydraulic Flow

**Quick Coupler.** An IT interface is standard on the B Series. Machines are equipped with the hydraulic quick coupler, allowing the operator to quickly and easily change work tools without leaving the cab.

**Tow Hitches.** A range of Tow Hitches are available to meet local market regulations. All Cat Telehandler models come with an ISO10532 rated retrieval point as standard.

**Work Tools.** A wide range of work tools are available to meet most job site applications.

Caterpillar Telehandler Work Tools extend the versatility of the machine. Built for performance and durability, these work tools deliver high productivity, long life and excellent value.

- General Purpose Bucket (1.0 m<sup>3</sup>)
- Material Handling Bucket (1.5 m<sup>3</sup>)
- Multi Purpose Bucket (1.0 m<sup>3</sup>)
- Grapple Bucket (0.85 m<sup>3</sup>)
- Fixed Carriage
- Rotate Carriage
- Sideshift Carriage
- Wide Carriage
- Wide Rotate Carriage
- Pallet Forks
- Block Forks
- Lift Hook
- Truss Boom
- Self-tipping Hopper
- Material Handling Arm
- Pickup Broom

**Access Platforms.** Caterpillar offers 2 Access Platforms, designed to fully utilize the integrated electro-hydraulic control system on the B Series.

All models of Cat Access Platforms will have fully proportional joystick control of boom functions from the platform. Interlocks on the machine isolate all cab controls when the access platform is operational. The following access platforms are available:

- 1000 mm wide (fixed)
- 2400 mm wide, 180 degree swivel platform



## Cost of Ownership

*Specifically designed to lower your owning and operating costs.*

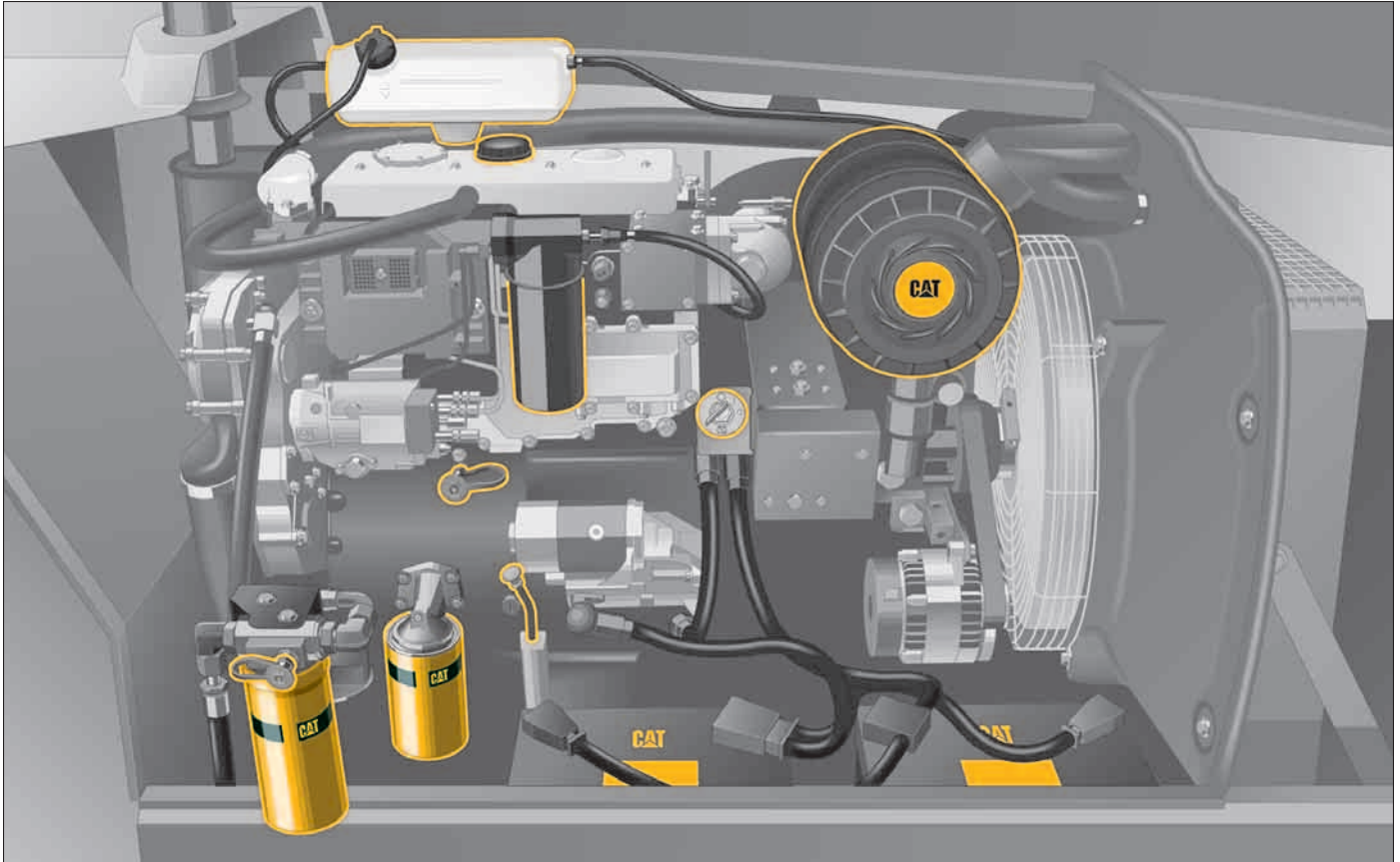

**Ease of Access.** Cost of ownership starts with ease of service. All Cat Telehandler service points are readily accessible and major components are easy to reach at ground level due to overall machine design.

**Daily Maintenance.** Routine daily maintenance is now reduced to checking fluid levels and a walkaround inspection.

**Service Intervals.** Engine oil, filter changes and routine lubrication are now only required every 500 hours.

**Reduced Componentry.** The combined hydraulic/transmission oil filter requires changing at 1000 hours. With the reduction in the number of filters and extended service intervals, owning and operating costs are the lowest in the industry.

**Machine Security System.** Secure your investment with Caterpillar's Machine Security System (MSS), a programmable key system that provides maximum machine security for Cat Telehandler owners.

- MSS disables machine by interacting with the machine's Electronic Control Modules (ECM)
- Keys fit all existing Cat machines (including machines without MSS)
- Each machine can store up to 50 key identifications
- Each key can be configured to operate a certain range of machines or enable operation for a certain period of time

## Serviceability and Customer Support

*Caterpillar Dealer Services enables you to operate longer with lower costs, helped by significantly extended service intervals.*



**Access.** All Cat Telehandler service points, including the combined transmission/hydraulic oil filter, are readily accessible and major components are easy to reach at ground level due to the overall machine design. A cab mounted service point allows access to the fuel fill, hydraulic oil fill, washer bottle, fuse box and cab air filter for daily checks.

**Selection.** Make detailed comparisons before you buy. Your Cat Dealer can give you precise answers to these questions.

**Purchase.** Look at the value that the TH460B Telehandler will offer you. Consider all the flexible financing options your Cat Dealer offers as well as day to day operating costs.

**Operation.** Improving operating techniques can boost your profits. Your Cat Dealer has training literature and other ideas to help increase your productivity.

**Maintenance.** Repair options guarantee the cost of repairs up front. Diagnostic programs such as Scheduled Oil Sampling and Technical Analysis help you avoid unscheduled repairs.

**Replacement.** Repair, rebuild or replace? Your Cat Dealer can help you evaluate the cost involved so you can make the right choice.

**Product Support.** You will find high availability of parts at our Dealer parts counter. Cat Dealers utilize a worldwide computer network to find in-stock parts to minimize machine downtime.

**Easy Financing.** Your Cat Dealer can provide a financing package to meet your needs.

**Product Link.** This established Caterpillar technology uses a Global Positioning System (GPS) to provide additional machine data to both Cat dealers and end users. Data can be received by either a web based application system or notifications by email or pager. Product Link can provide:

- Machine hours
- Location four times a day
- Notifications via email or pager
- Total fuel consumption
- Events and diagnostics from data link



## Cat Engine 3054E

Ratings	2200 rpm
Gross Power	74.5 kW/99.9 hp
Maximum Net Power	
ISO 9249	73.1 kW/97.9 hp
EEC 80/1269	73.1 kW/97.9 hp
Maximum Torque at 1400 rpm	410 Nm
Bore	105 mm
Stroke	127 mm
Displacement	4.4 liters

- Maximum net power shown is the power available at the flywheel when the engine is equipped with fan, air cleaner, muffler and alternator.
- Engine meets EU directive 97/68/EC Stage II emissions regulations.

## Boom Performance

	seconds
Boom Up	17
Boom Down	13
Tele In	14
Tele Out	14
Crowd Forward (dump)	3
Crowd Backward	3
Combined	
Up and Out	36
Down and In	20

## Hydraulic System

Maximum System Pressure	250 bar
Maximum Pump Flow	113 L/min
Auxiliary Hydraulic Supply	60 L/min
Pump Type	
Variable Displacement Load Sensing	
Axial Piston Pump	

## Brakes

Service Brake	Servo assisted on front axle
Parking Brake	Dry disc on front axle

## Tires

Standard	14.00-24 Cat
----------	--------------

## Operating Specifications

Rated Load Capacity	4000 kg
Maximum Lift Height	13 500 mm
Load at Maximum Height	
Stabilizers Down	4000 kg
Stabilizers Up	1500 kg
Maximum Forward Reach	9200 mm
Load at Maximum Reach	
Stabilizers Down	1500 kg
Stabilizers Up	450 kg
Top Travel Speed	32 km/h

## Transmission Speeds

	km/h
Forward	
1	6
2	12
3	20
4	32
Reverse	
1	6
2	12
3	20

## Sound

**Operator Sound.** The operator sound level measured according to the procedures specified in ISO 6396 is 80 dB(A).

**Exterior Sound.** The labeled spectator sound power level measured according to the test procedures and conditions specified in 2000/14/EC is 105 dB(A).

## Service Refill Capacities

Fuel Tank	100 liters
Hydraulic Tank	65 liters

## Weights

Operating Weight	10500 kg
------------------	----------

# Load Charts and Dimensions

## Stabilizers Up (Frame Level)

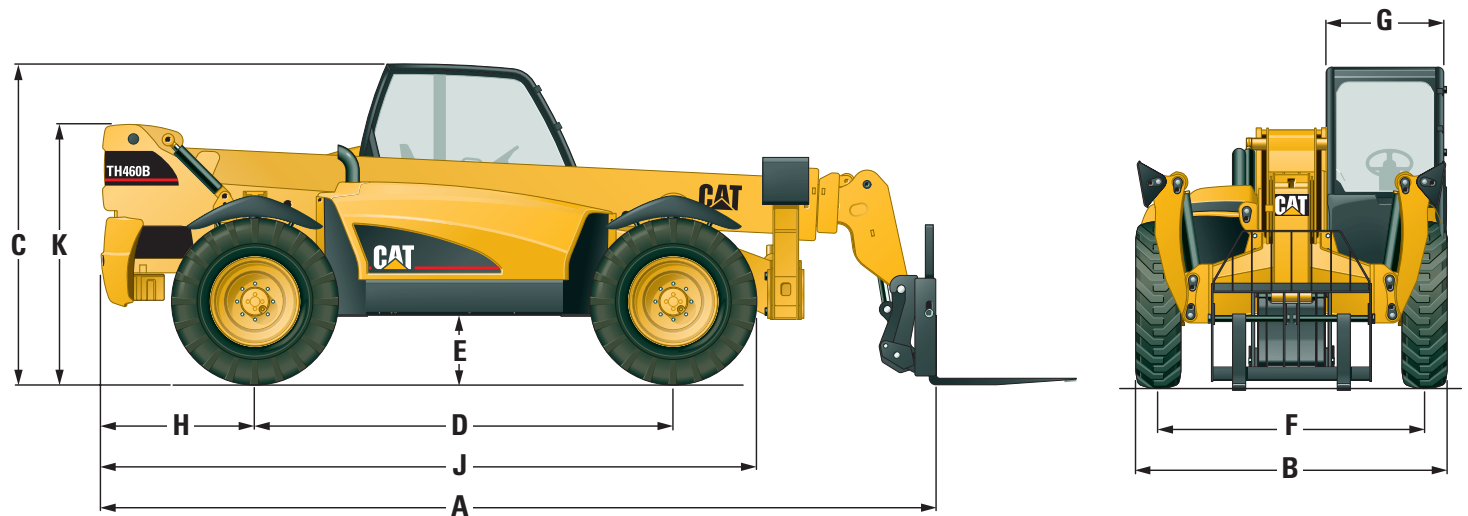
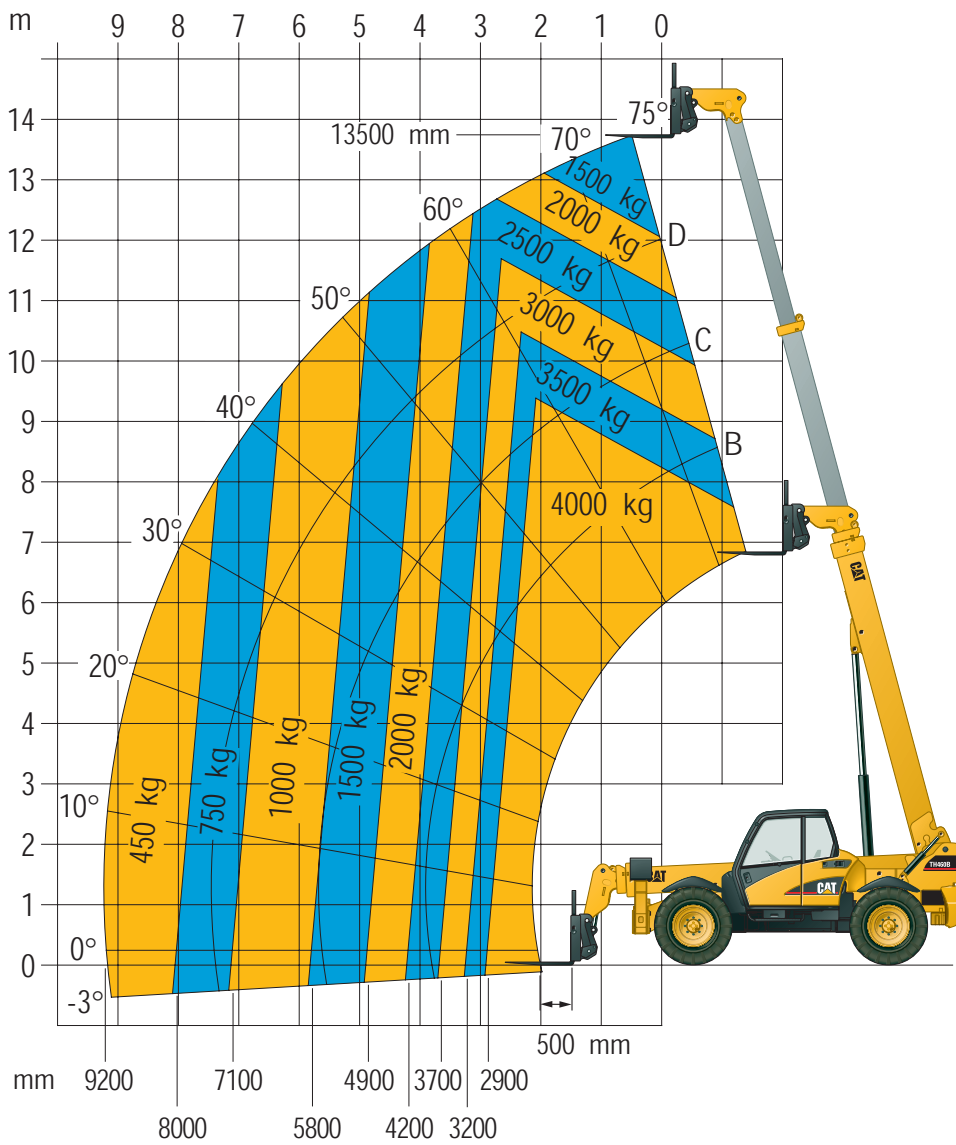



## Stabilizers Down

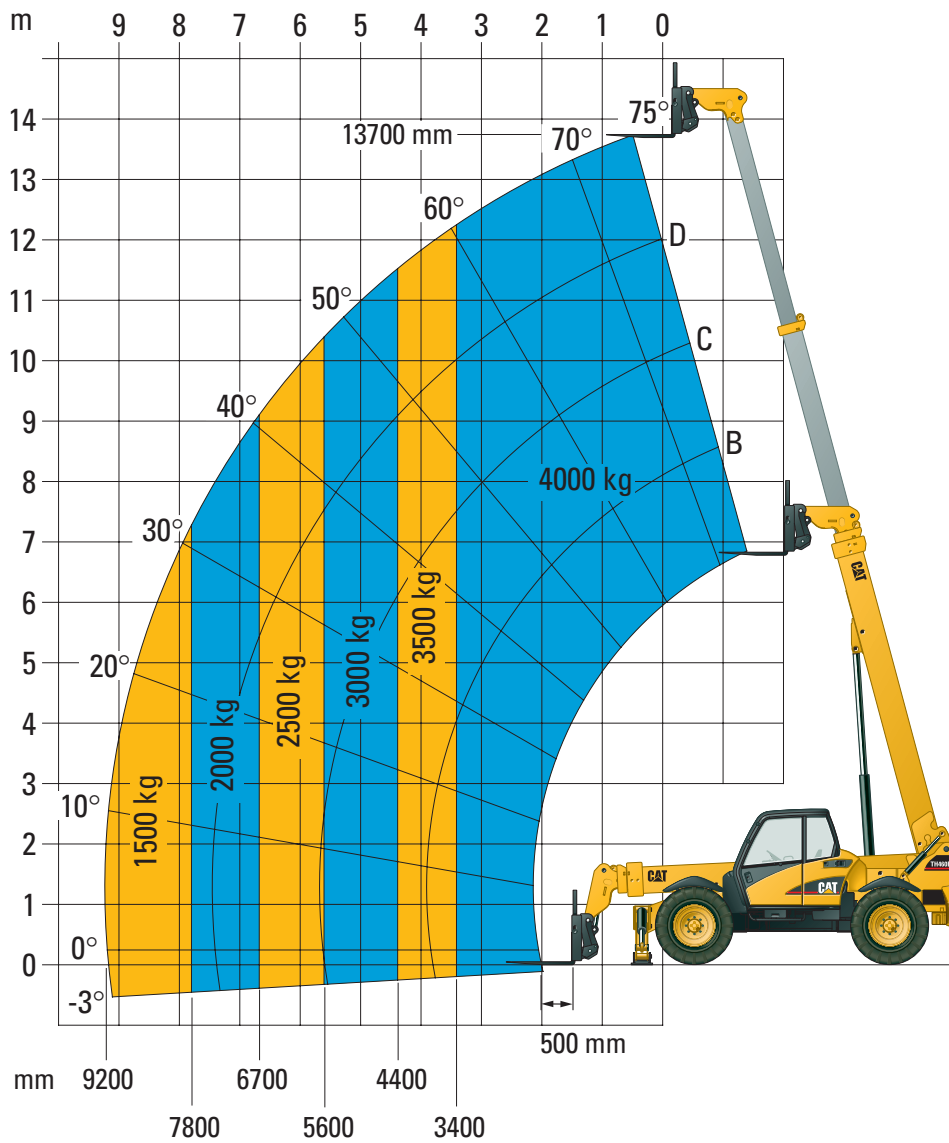

	mm
<b>A</b> Length to Carriage	6550
<b>B</b> Width	2515
<b>C</b> Height	2530
<b>D</b> Wheelbase	3250
<b>E</b> Ground Clearance	505
<b>F</b> Track	2150
<b>G</b> Cab Width	900
<b>H</b> Rear Overhang	1200
<b>J</b> Length to Front of Tire	5135
<b>K</b> Rear Boom Height	2070
Outside Turning Radius over Tires	3800
Outside Turning Radius over Forks	5450

## Standard Equipment

Standard equipment may vary. Consult your Caterpillar dealer for specifics.

### Telescopic Boom

Wear pads, non-metallic  
Lock valve on hydraulic cylinders  
Boom angle indicator  
Single auxiliary to the boom head

### Electrical

Alternator, 90-amp  
Anti-restart key switch  
Battery, Maintenance-free, 12 volt,  
750 CCA  
Battery disconnect  
Horn  
Alarm, Back up  
Electronic Control Module  
Power Sockets, 12 volt internal  
and external  
'Electronic Technician'  
diagnostic connection

### Operator Station

Enclosed cab, ROPS/FOPS  
Joystick, Electronic  
Adjustable joystick wrist rest  
Low step, grab bars for easy entry  
2 way adjustable seat, seat belt  
Steering wheel spinner knob  
Floor mat  
Right side rear view mirror  
Service Door, Cab air intake filter,  
fuel fill, hydraulic fill, level indicator,  
fuse panel and washer fill  
Instrument Cluster with:  
powertrain and system monitor,  
longitudinal stability indicator,  
steering alignment indicator,  
fuel gauge,  
engine oil temperature gauge,  
engine water temperature gauge,  
hydraulic transmission temperature,  
SMU and air filter blockage light  
2 piece entry door  
Cup holder  
Fixed Steering Column  
Headliner  
Door pocket  
Radio ready

### Powertrain

Engine, Caterpillar 3054E  
Air cleaner; Dual element and filter  
condition indicator  
Thermal starting aid  
Water separator  
Transmission, Caterpillar 4 forward/  
3 reverse powersyncro  
Direction change, single lever,  
column mounted  
Spin-on filters; engine oil filter,  
hydraulic/transmission filter  
Axles, Caterpillar; planetary drive,  
full time mechanical 4-wheel drive,  
Integrated steer cylinders protected  
above axles  
Steering, power assisted, enclosed oil  
disc brakes, front axle  
Parking brake, dry disc with  
transmission disconnect  
Differential lock  
Auto steering align

### Structure

Chassis, frame level  
Stabilizers  
Hydraulic Quick Coupler

### Antifreeze

Antifreeze, extended life -36°C

### Tires

Cat Brand 14.00-24

### Other Equipment

Integrated lift and tie down points  
Padlock on power module  
Retrieval Point  
Standard Cat color paint  
Fenders  
Lockable storage drawer



## Optional Equipment

Optional Equipment may vary. Consult your Caterpillar dealer for details.

### Electrical

Light packages; boom lights,  
  roading lights, cab lights  
Alternator, 105 amps  
Product Link  
Dual battery  
Stabilizer interlock  
7 pin trailer services socket  
Engine heater block,  
  240V/750 Watts

### Operator Station

Canopy, ROPS/FOPS  
Air conditioning  
Seats; cloth suspension,  
  cloth air-suspension  
Sun visor  
Screen guard  
Additional left hand mirror  
Rear wash/wipe  
Machine Security System (MSS)  
Beacon, magnetic mount  
Adjustable steering column  
Auxiliary hydraulic continuous  
  flow switch  
Adjustable joystick armrest

### Transmission

Caterpillar 5 speed forward/  
  3 speed reverse powersyncro

### Structure

Stabilizers complete with  
  access platform sensors

### Anti-Freeze

Anti-freeze, extended life -50°C

### Tires

AR 14.00-24 CAT Trak'N'Seal  
14.00-24 SGG-2ATL Goodyear  
400/70 R24 Goodyear

### Other Equipment

Custom color

### Work Tools

Carriage; standard, rotate, wide frame,  
  wide frame (rotate), side-shift

Forks:

Pallet forks 50 x 100 x 1220 mm  
Block forks 50 x 50 x 1220 mm  
Pallet forks 50 x 100 x 1520 mm

Buckets:

General Purpose 1.0 m<sup>3</sup>  
Multi Purpose 1.0 m<sup>3</sup>, width 2450 mm  
Material Handling 1.5 m<sup>3</sup>, width 2450 mm  
Multi-grapple 0.85 m<sup>3</sup>, width 2350 mm

Material Handling Arm

Self-tipping Hopper, 1.2 m<sup>3</sup>

Lifting Hook

Truss Boom

Pick-up Broom

Access Platforms:

- Small, 1000 mm wide platform
- Swivel, 2400 mm wide platform

### Other Attachments

Tow hitches; hitch, manual rear-tow

Hitches complete width adjustable  
frame height:

Hitch, tow, category "C" clevis  
Hitch, towing, manual  
Hitch, towing, auto

# TH460B Telehandler

HEHB2807-1 (04/2005) hr

Materials and specifications are subject to change without notice.  
Featured machines may include additional equipment.  
See your Caterpillar dealer for available options.

[www.CAT.com](http://www.CAT.com)  
© 2003 Caterpillar

**CATERPILLAR**<sup>®</sup>