

General Specifications

Link-Belt® 35-ton (31.77 metric ton)

Wire rope truck crane

GENERAL INFORMATION ONLY

HC-78B

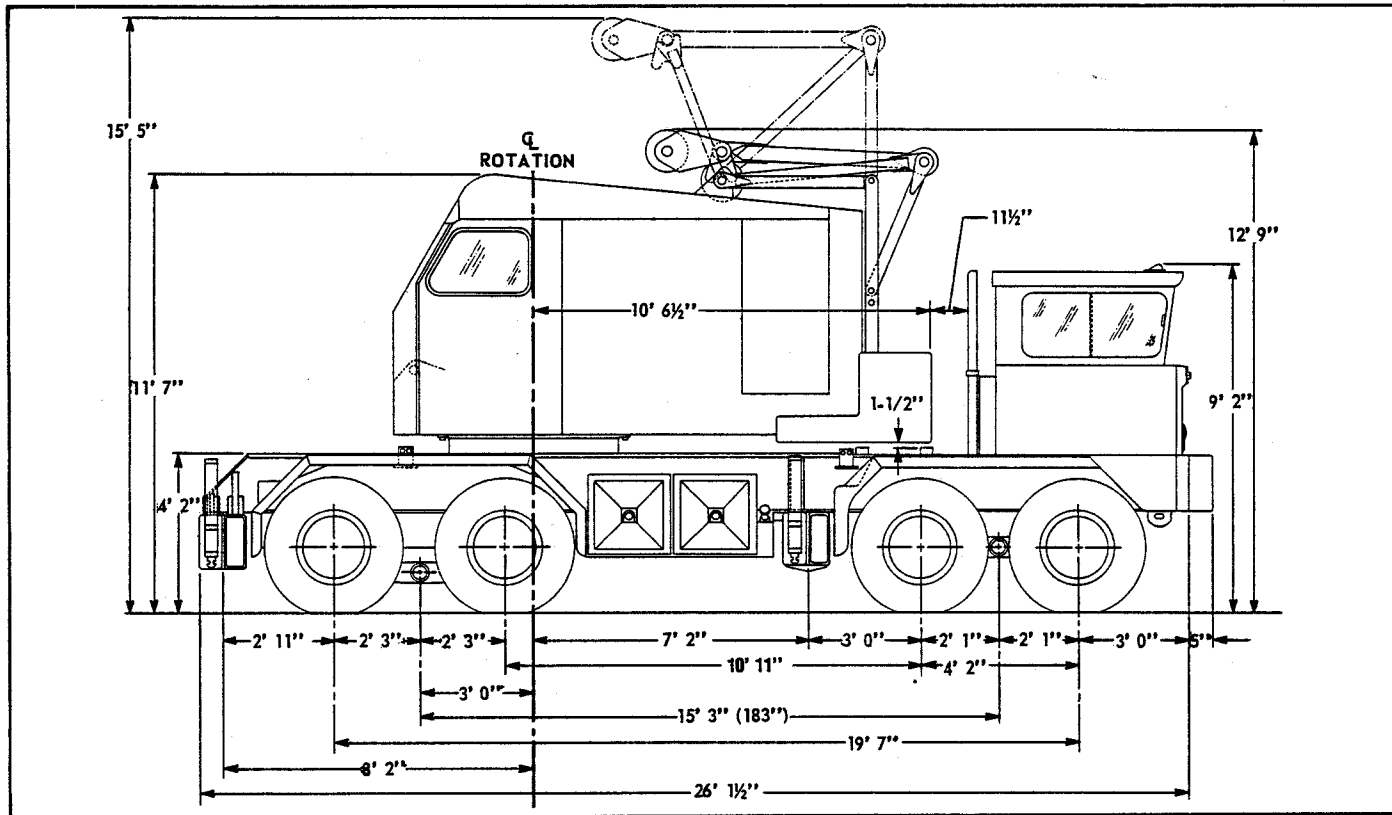

General Dimensions	Feet	Meters
Overall width; outriggers extended (over floats)	19' 2"	5.84
Overall width; outriggers extended (centerline of jacks)	17' 0"	5.18
Overall width; outriggers retracted (floats removed)	9' 0"	2.74
Vehicle clearance circle; over outside of front bumper	90' 0"	27.43
Vehicle clearance circle; over outside of front bumper counterweight	89' 4"	27.23
Minimum ground clearance	10"	0.25
Counterweight tailswing; across corners	10' 7"	3.23
Overall cab width	7' 10"	2.38
Basic boom length — angle	35' 0"	10.67
— tubular	40' 0"	12.19
Radius of boom hinge pin — angle	3' 1"	0.93
— tubular	4' 2"	1.27
Height of boom hinge pin — angle	6' 5"	1.96
— tubular	5' 6"	1.67
Overall length; with boom in travel position over rear of carrier with —		
35' angle boom	56' 7"	17.25
40' tubular boom	62' 8"	19.10
Overall length; with boom in travel position over front of carrier with —		
35' angle boom	47' 9"	14.56
40' tubular boom	53' 10"	16.40
Height; over extended boom live mast with basic 40' tubular boom in travel position		
over rear of carrier	14' 0"	4.27
Ground clearance under counterweight	4' 6"	1.37

Axle loadings — approximate

Based on standard HC-78B revolving upperstructure equipped with GM 3-71N diesel engine with friction counterweight "A", mounted on FMC 183" (4.65 m) wheelbase, 8 x 4 drive, 9' 0" (2.74 m) wide carrier equipped with 12:00 x 20G (14-ply rating) military type, non-directional tread tires, hydraulic outrigger assemblies with 4 floats, GM 8.3T diesel engine and 2,000 lb. (907 kg) front bumper counterweight.

	Basic machine Gross weight		Upper facing front				Upper facing rear				
			Front		Rear		Front		Rear		
	**	Lbs.	kg	Lbs.	kg	Lbs.	kg	Lbs.	kg	Lbs.	kg
A	35,595	16 146	- 5,660	- 2 567	41,225	18 713	19,665	8 920	15,930	7 226	
B	33,180	15 050	15,080	6 840	18,100	8 210	15,080	6 840	18,100	8 210	
C	68,775	31 196	9,420	4 273	59,355	26 923	34,745	15 760	34,030	15 436	
Adjust axle loadings accordingly for the following components:											
	Component weights		Front		Rear		Front		Rear		
	Lbs.	kg	Lbs.	kg	Lbs.	kg	Lbs.	kg	Lbs.	kg	
Revolving upperstructure —											
Counterweight "A" (standard)	- 15,200	- 6 895	+ 4,920	+ 1 946	- 19,490	- 8 841	- 12,040	- 5 461	- 3,160	- 1 433	
Boomhoist rope — 240' (73 m), 5/8" (16 mm) diameter, Type "N" for angle boom	+ 173	+ 78	+ 9	+ 4	+ 164	+ 74	+ 82	+ 37	+ 91	+ 41	
Boomhoist rope — 430' (131 m), 1/2" (13 mm) diameter, Type "N" for tubular boom	+ 200	+ 91	+ 10	+ 5	+ 190	+ 86	+ 95	+ 43	+ 105	+ 48	
Rear drum planetary drive unit	+ 450	+ 204	+ 40	+ 18	+ 410	+ 186	+ 140	+ 64	+ 310	+ 141	
Rear drum rope — 530' (162 m), 5/8" (16 mm) diameter, Type "N"	+ 380	+ 172	+ 15	+ 7	+ 365	+ 166	+ 180	+ 82	+ 200	+ 91	
Front drum planetary drive unit	+ 450	+ 204	+ 120	+ 54	+ 330	+ 150	+ 60	+ 27	+ 390	+ 177	
Front drum rope — 530' (162 m), 5/8" (16 mm) diameter, Type "F"	+ 380	+ 172	+ 80	+ 36	+ 300	+ 136	+ 115	+ 52	+ 265	+ 120	
Third operating drum	+ 710	+ 322	+ 200	+ 91	+ 510	+ 231	+ 80	+ 36	+ 630	+ 286	
Third drum rope — 278' (85 m), 5/8" (16 mm) diameter, Type "N"	+ 200	+ 91	+ 70	+ 32	+ 130	+ 59	+ 30	+ 14	+ 170	+ 77	
Optional GM 3-71N diesel engine with single stage torque converter	+ 700	+ 318	+ 113	+ 51	+ 587	+ 266	+ 164	+ 74	+ 536	+ 243	
Attachment —											
35' (10.67 m) angle boom (open throat top section) with accessories	+ 3,370	+ 1 529	+ 5,780	+ 2 622	- 2,410	- 1 093	- 4,460	- 2 023	+ 7,830	+ 3 552	
20' (6.10 m) angle boom base section with accessories	+ 1,730	+ 785	+ 2,000	+ 907	- 270	- 122	- 1,320	- 599	+ 3,050	+ 1 383	
40' (12.19 m) tubular boom (open throat top section), boom foot adaptor and accessories	+ 5,070	+ 2 300	+ 8,580	+ 3 892	- 3,510	- 1 592	- 6,580	- 2 985	+ 11,650	+ 5 284	
20' (6.10 m) tubular boom base section, boom foot adaptor and accessories	+ 3,210	+ 1 456	+ 3,280	+ 1 488	- 70	- 32	- 2,020	- 916	+ 5,230	+ 2 372	
Boom live mast (tubular boom only), bridle and spreader bar	+ 2,570	+ 1 166	+ 3,030	+ 1 374	- 460	- 209	- 2,020	- 916	+ 4,590	+ 2 082	
Boom stops and live mast stops	+ 510	+ 231	+ 570	+ 259	- 60	- 27	- 370	- 168	+ 880	+ 399	
Mounting —											
Front outrigger beams and jacks	- 1,930	- 875	- 1,290	- 585	- 640	- 290	- 1,280	- 585	- 640	- 290	
Rear outrigger box, beams and jacks	- 3,080	- 1 397	- 1,040	- 472	- 4,120	- 1 869	+ 1,040	+ 472	- 4,120	- 1 869	
Rear outrigger beams and jacks	- 1,930	- 875	+ 656	+ 298	- 2,856	- 1 295	+ 656	+ 298	- 2,856	- 1 295	
Four floats	- 260	- 118	+ 104	+ 47	+ 156	+ 71	+ 104	+ 47	+ 156	+ 71	
Front bumper counterweight	- 2,000	- 907	- 2,700	- 1 225	+ 700	+ 318	- 2,700	- 1 225	+ 700	+ 318	

** "A" is upper; "B" is mounting, "C" is total gross weight.

General specifications

Mounting —



Type



Bumper counterweight

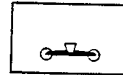

Bogie

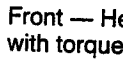

Rear axles



Front axles



Bogie

Frame — Reinforced, wide flange beam main members; machined surface provided for mounting inner race of turntable bearing on carrier.



Turntable bearing

Easily removed, mounts on front bumper hooks; 2,000 lb (907 kg).

Front — Hendrickson equalized beams with torque rods; rubber bushed.

Tandem bogie beam mounted. Clark planetary BD45-60; 80" (2.03 m) track.

Tandem bogie beam mounted. Rockwell Standard FF-931; 78 3/8" (2.00 m) track.

Rear — Hendrickson equalized beams with torque rods; bronze bushed.

Outer race, with integral swing (ring) gear bolted to carrier.

Wheels and rims — Cast spoke type on front; integral with planetary hub on rear.
Rims — 8:00V 20" (0.51 m) on front; 20 x 8.0, 5 degree on rear.



Tires

Single tires front; dual tires rear.

Standard — 12:00 x 20G (14-ply rating).

Optional — 12:00 x 20G Goodyear SRL-1; 12:00 x 20G General HCT Nygen highway type; all 14-ply rating.

Brakes — 8-wheel air brakes.

Service — Dual diaphragm air chambers on two front rear wheels. Single diaphragm air chambers on two rear rear wheels and on all four of the front wheels.

Size and area — Rear wheels; 16½" x 7" (0.42 m x 0.18 m); total effective lining area 910 sq. in. (5 872 cm²). Front wheels; 15.5" x 5" (0.39 m x 0.13 m); total effective lining area 1,256 sq. in. (8 105 cm²).

Digging — Service brakes applied by hand controlled air valve on carrier dash.

Parking — Two rear wheel brakes applied with air control valve on carrier dash.

Emergency — Brakes on two front rear wheels apply when air pressure drops below 40 p.s.i. (275.8 kPa) in system. Emergency brake may be manually applied anytime by hand control of dash-mounted air control valve.



Steering

Power hydraulic assist. Ross HPS 70 steering gear; 18" (0.46 m) diameter steering wheel.

Turning radius — 39' 11" (12.17 m).

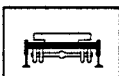

Outriggers

Full width, double box, front and rear. Non-removable front outrigger box; rear outrigger box pin-connected to carrier frame. Hydraulically operated beam and jack cylinders are individually controlled from either side of carrier. Hydraulic power supplied by upper engine driven hydraulic pump. Check valve at each jack cylinder.

Floats — Low profile, alloy steel lightweight; 26" (0.66 m) square base.



Electrical system

12-volt; including dual sealed beam headlights, directional signals with 4-way flashing system, stop and tail lights, clearance and back-up lights, back-up alarm, horn, cab dome light, headlight dimmer switch, lighted instrument panel, windshield wiper and washer, and two 12-volt, 90 ampere hour (20 hour rate) batteries.

Cab — One-man, fully enclosed. Rubber suspension mounted bucket seat with seat belt. Instrument panel and dash includes speedometer, odometer, ammeter, gauges for fuel, engine temperature, air and oil pressures. Low air pressure warning buzzer, key switch and pushbutton start, throttle control, fire extinguisher, heater and defroster fan and cigar lighter.

Standard Auxiliary Equipment — Bus-type rear view mirrors, boom guide, lug wrench, 2-way reading bubble levels at four positions on carrier. High pressure lube fittings at all bearing points, removable rear fenders, storage type running boards, hand grab rails, and skid-resistant finish on carrier deck.

Fuel tanks

Two 39 gallon (147 L) fuel tanks.

Approximate carrier weight, less turntable bearing:
...31,180 lbs. (14 143 kg) without bumper counterweight,
...33,180 lbs. (15 050 kg) with bumper counterweight.

Engine specifications	General Motors 8.2T
Number of cylinders	8
Bore	4.25" (1.29 m)
Stroke	4.41" (1.34 m)
Piston displacement (cu. in.)	500 (8.19 cm ³)
Max. brake h.p. @ full load speed r.p.m.	—
Governed load speed (r.p.m.)	205 (156.28 kW) @ 3,000 (1)
Peak torque/r.p.m.	3,000
Electrical system	430 @ 1,700
Batteries	12-volt
Compression ratio	2 12-volt
Clutch or power take-off	16.9:1
	Single plate, dry disc

(1) Stripped engine

GENERAL INFORMATION ONLY

Clutch — 14" (0.36 m) spring loaded, single plate, dry disc. Foot actuated; equipped with FMC spring loaded "power a" mechanism.

Transmission — Eaton RT6613; 13 speeds forward, 3 reverse.

Universals — Mechanics needle bearing.

Carrier speeds —

Based on GM 8.2T diesel engine running at 3,000 r.p.m. governed load speed.				
Gear		Main — Eaton RT6613		
		Ratio	M.p.h.	km/h
High	13th	1.00	40.44	65.07
	12th	1.25	32.35	52.05
	11th	1.60	25.27	40.66
	10th	2.05	19.73	31.75
	9th	2.61	15.49	24.92
	Reverse	2.78	14.55	23.41
Intermediate	8th	3.29	12.29	19.77
	7th	4.11	9.84	15.83
	6th	5.26	7.69	12.37
	5th	6.74	6.00	9.65
	4th	8.61	4.69	7.55
	Reverse	9.15	4.42	7.11
Low	3rd	10.96	3.69	5.94
	2nd	14.04	2.88	4.63
	1st	17.93	2.25	3.62
	Reverse	19.06	2.12	3.41

Revolving upperstructure



Frame

All welded, stress relieved, precision machined; machinery side housings bolted to upper frame.



Turntable bearing

Inner race of bearing bolted to machined surface on under side of frame.

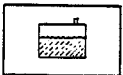

Fuel tank

43 gallon (163 L) capacity tank equipped with flame arrester fill unit, self-closing cap with locking eye for padlock, and fuel level gauge.

Power train

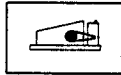

Transmission

Triple roller chain enclosed in oil tight chain case with integral lubrication system.



Engines

Diesel; full pressure lubrication, oil filter, air cleaner, hour meter, foot and optional hand throttles. Manual control shutdown for engines.

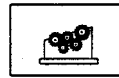

Machinery gear train

"Full Function" design, two-directional power available to all operating shafts; shafts mounted on anti-friction bearings in precision bored machinery side housings. All load hoist, swing, and boomhoist functions independent of one another. Components such as gears, pinions, chain wheels, brake drums and clutch spiders involute splined to shafts. Drum gear/clutch drum assemblies bolted together and mounted on shafts on anti-friction bearings. Machine-cut teeth on drum gears, pinions, spur gears, and chain wheel. Chain wheel and pinion fully enclosed and running in oil.

Principal operating functions



Control system

Speed-o-Matic® power hydraulic control system; a variable pressure system requiring no bleeding. Operating pressure transmitted to all 2-shoe clutch cylinders, and other hydraulic cylinders as required. System includes constant displacement, engine driven, vane type hydraulic pump to provide flow of oil; accumulator to maintain system operating pressure, unloader valve to control pressure in accumulator, relief valve to limit maximum pressure buildup in system, full-flow filter with 40 micron disposable filter element, and variable pressure control valves to control drum clutches and other operating cylinders.

Engines —	GM 3-71N	GM 3-71N (1)	GM 4-71N	Cat. 3304-NA
Number cylinders	3	3	4	4
Bore and stroke (inches)	4 1/4 x 5	4 1/4 x 5	4 1/4 x 5	4.77 x 6.0
Piston displacement (cu. in.)	212.7	212.7	283.7	425
High idle speed — r.p.m.	1,990	1,610	1,408	1,990
Engine full load speed — r.p.m.	1,815	1,905	1,268	1,870
Net engine h.p. @ F.L.S.	84	85	80	80
Peak torque — ft. lbs.	271	645	351	284
Peak torque — r.p.m.	1,200	Output shaft stall	1,200	1,150
Electrical system	12-volt	12-volt	12-volt	12-volt
Batteries (one 12 volt is used for export)	2/6-volt	2/6-volt	2/6-volt	
Clutch — Type	Friction	Clutch between engine & converter	Friction	Friction
— Make	Rockford		Rockford	Twin Disc
— Model	PTA-11111		PTA-1111	SP-111-HP-1
Transmission —				
No. chain wheel teeth	161	161	161	161
No. engine pinion teeth	17	21	24	17

(1) Allison single-stage torque converter.

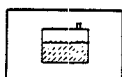

Hydraulic oil reservoir

FMC; 12.9 gallon (48.82 liter) capacity with filter and strainer assembly.

Load hoisting and lowering —

Wire rope drum gear train (front and rear main, and optional third, operating drums) powered by chain transmission from engine.



Load hoist drums

Front and rear main operating drums — Two-piece, removable; bolted to brake drum and clamped to shaft. 12" (0.30 m) root diameter smooth drum for crane service; 14" (0.36 m) root diameter grooved drum for clamshell/dragline. Ratchet wheel for drum locking pawl is integral with each drum flange.

Third operating drum — Optional; mounts forward of front main operating drum. Functions as third operating drum with control and design similar to front and rear main operating drums. One-piece, 9" (0.23 m) or 11" (0.28 m) root diameter smooth drums, involute splined to shaft. Ratchet wheel for drum locking pawl is integral with drum flange. **Note:** On machine equipped with third drum, the following must be noted:

Dragline Operation — To avoid interference with inhaul (front drum) wire rope, third drum wire rope and lagging must be removed.

Lifting Crane Operation — When using front drum, amount of wire rope on third drum will have to be limited in some cases — particularly when operating at maximum radii — to avoid interference between wire ropes on front and third drums.



Drum clutches

Speed-o-Matic® power hydraulic 2-shoe clutches. Internal expanding, lined aluminum alloy shoes; clutch spiders splined to shafts, clutch drums bolted to drum spur gears and mounted on shafts on anti-friction bearings. Clutches for front and rear main operating drums, swing, boom hoist and lowering, and power load lowering on front and rear main operating drums — 18" (0.46 m) diameter, 4½" (0.11 m) face width. Hoist clutch for optional third operating drum — 17¼" (0.43 m) diameter, 4" (0.10 m) face width.

Planetary Drive Units — for load hoist and/or lowering on front and rear main operating drums. Planetary unit mounts between spur gear and 2-shoe clutch drum on extended shaft; permits increase or decrease of standard hoist and load lowering wire rope speeds. **Note:** Not available for load lowering on front drum and not available for hoisting or load lowering on either drum on machine equipped.

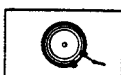

Drum brakes

Two-piece, external contracting band; mechanically foot pedal operated. Foot pedals equipped with latch to permit locking brakes in applied position.

Front and rear main drums — 23" (0.58 m) diameter x 3¾" (0.09 m) face width.

Optional third drum — 18" (0.46 m) diameter x 3" (0.07 m) face width.

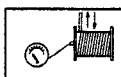

Drum rotation indicators

Standard for front and rear main operating drums. Dials, mounted on front of control stand, actuated by flexible shaft drives attached to drum shafts.

Swing system —

Horizontal Swing Shaft — Mounted in line bore on anti-friction bearings.

Spur Gears — Machine-cut teeth; mounted on shaft on anti-friction bearings.

Bevel Gear — Machine-cut teeth; involute splined to shaft, enclosed and running in oil.

Vertical Swing Shaft — Mounted in line bore on anti-friction bearings.

Bevel Gear — Machine-cut teeth; involute splined to shaft, enclosed and running in oil.

Swing Pinion — Involute splined to shaft; teeth mesh with internal teeth of swing gear which is integral with inner race of turntable bearing.

Swing Brake — Two-directional, external contracting band, spring applied, power hydraulically released; 11" diameter 2" face width.

Swing Brake Drum — Involute splined to shaft.

Swing Lock — Mechanically controlled pawl engages internal teeth of turntable bearing swing gear.

Swing Speed — 4.2 r.p.m.

Boom hoist/lowering system —

Independent boomhoist. Spur gear driven; precision boom hoisting or lowering controlled through 2-shoe power hydraulic clutches. Boomhoist rope drum locking pawl, manually controlled from operator's position, is standard.

Shaft — Mounted in line bore on anti-friction bearings.

Spur Gear — Machine-cut teeth; mounted on shaft on anti-friction bearings.

Wire Rope Drum — Involute splined to shaft; ratchet wheel for locking pawl cast integral with drum.

Brake — External contracting band, spring applied, hydraulically released; 19" diameter, 3" face width.

Brake Drum — Involute splined to shaft.

Boomhoist Limiting Device — When boom is raised above pre-determined minimum radius, boom contacts mechanical device which causes hydraulic pressure to by-pass boomhoist clutch and automatically sets brake. Boom must first be lowered before it can be raised again.



Electrical system

Battery. Two 6-volt batteries (one 12-volt battery used for export machines).

Optional — Battery lighting system, including two sealed beam automotive type adjustable headlights located on cab front roof, one interior cab light and automotive type wiring.

Optional — Additional 50 watt sealed beam automotive type headlight mounted on boom. (Three maximum quantity recommended.)

Optional — Onan 3000 watt independent light plant. Includes four cycle, one cylinder, air cooled diesel engine and remote electric starting — 120 volt, three wire, single phase, 60 cycle A.C. Also includes wiring in conduit, interior cab lights, trouble lamp with cord, two 300 watt adjustable floodlights on cab front roof and cab extension when required. **Note:** The independent light plant cannot be furnished in conjunction with magnet generator due to lack of installation space, and it cannot be furnished in conjunction with third drum.

Optional — Additional 300 watt floodlight, cab mounted. Additional 300 watt floodlight, boom mounted.

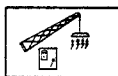

Magnet generator/control package

Optional — 10 kW belt driven magnet generator complete with magnet controller with 275/200 volt DC over excitation feature, wiring, voltmeter, magnet cable, Rud-O-Matic Model 636 combination tagline winder and magnet cable take-up reel, but no hook block or magnet. To be used with 230 volt magnets rated at 31 to 40 cold amperes.

Optional — 15 kW belt driven generator complete with magnet controller with 275/200 volt DC over excitation feature, wiring, voltmeter, magnet cable, Rud-O-Matic Model 636 combination tagline winder and magnet cable take-up reel, but no hook block or magnet. To be used with 230 volt magnets rated at 31 to 60 cold amperes.

Note: Magnet generators cannot be furnished in conjunction with optional independent light plant, and they are available only on machines equipped with either Caterpillar or General Motors engines equipped with friction clutches.



Operator's cab

Operator's door rolls to rear on ball bearing rollers, front window rolls up to overhead storage position on ball bearing rollers, side window slides to rear. Door and windows equipped with safety glass panels. Dry chemical fire extinguisher and hand grab rails — standard equipment. Optional — sound reduction material in cab, electric windshield wiper, cab heater and defroster fan.

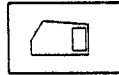

Machinery cab

Machinery access provided by hinged doors on sides and right front corner; rear doors roll on ball bearing rollers. Cab equipped with roof-top access ladder, electric warning horn, machinery guards, hand grab rails, and skid-resistant finish on roof.



Gantry

Retractable type, standard. Mounted to upper to support boom suspension system, bail, and two boomhoist wire rope guide sheaves. Required for use with either angle boom or tubular boom. Also used for power lowering of counterweight in conjunction with boom lowering clutch. **Note:** for tubular booms, boom live mast with midpoint boom suspension pendants is required in addition to retractable high gantry.

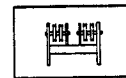

Gantry bail

Pinned to retractable gantry, supports boom suspension system. Angle boom — bail contains 3, 4, or 5 sheaves for 8, 10, or 12-part boomhoist reeving. Tubular boom — bail contains 5 sheaves for 12-part boomhoist reeving. Sheaves mounted on bronze bushings.

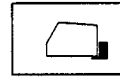

Counterweight

15,200 lbs. (6 895 kg); removable and held in position by "T" bolts. Power raising and lowering with retractable high gantry, in conjunction with boomhoist clutches, is standard. Optional — power hydraulic cylinder mounted between gantry backstays to raise or lower counterweight.

Booms and jibs



Angle boom

Boom — Angle. Two-piece, basic boom — 35' (10.67 m) long; 34" x 34" (0.85 x 0.85 m) wide at connections. Alloy steel main chord angles; 3" x 3" x 3/8" (76 x 76 x 15 mm) in base section; 3" x 3" x 1/8" (76 x 76 x 7 mm) in top section.

Base section — 20' (6.10 m) long.

Boomfeet — 1 1/8" (41 mm) thick on 34" (0.89 m) centers; 2 3/4" (69 mm) diameter boom foot pins.

Boom extensions — Available in 5' (1.52 m), 10' (3.05 m) and 20' (6.10 m) lengths; 34" x 34" (0.85 m x 0.85 m) wide. Appropriate length pairs of pendants with each extension.

Boom connections — Pin connections, standard; bolted connections, optional.

Boom top section — Open throat; 15' (4.57 m) long.

Boompoint machinery — 18" (0.46 m) root diameter sheaves; mounted on anti-friction bearings. Three sheaves, standard; one, two or four, optional.

Boompoint sheave guards — Standard: rigid, round steel rod bolted over top of sheaves and round steel rods between sheaves.

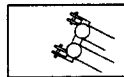

Boomhoist bridle

Serves as connection between boom pendants and boomhoist wire rope reeving. Contains four 11" (0.28 m) root diameter sheaves — mounted on anti-friction bearings — for standard 8-part or optional 10-part boomhoist reeving; six sheaves for optional 12-part boomhoist reeving.



Boom stops

Dual, fixed, tubular type with spring load bumpers; mounted on top of cab.

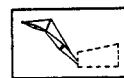

Angle jib

Two-piece, basic jib — 20' (6.10 m) long; 22 3/4" (0.57 m) wide, 18" (0.46 m) deep at connections.

Base section — 10' (3.05 m) long; mounted to bracket welded on end of boom top section.

Jib extensions — Available in 10' (3.05 m) lengths for 30' or 40' (9.14 or 12.19 m) jibs.

Jib connections — Bolted.

Jib tip section — 10' (3.05 m) long; single peak sheave 15 7/8" (0.40 m) root diameter; mounted on anti-friction bearings.



Tubular boom

Two-piece, basic boom 40' (12.19 m) long; 48" (1.22 m) wide, 39" (11.88 m) deep at connections. Alloy steel round tubular main chords, 2 1/2" (63 mm) outside diameter with round tubular steel lattice bracing.

Base section — 20' (6.10 m) long.

Boomfeet — 2" (50 mm) thick on 48" (1.22 m) centers; 2 3/4" (69 mm) diameter boom foot pins.

Boomfoot adaptor — Required to adapt 48" (1.22 m) tubular boomfoot centers to 35" (0.89 m) centers on upper revolving frame.

Boom extensions — Available in 10' (3.05 m), 20' (6.10 m) and 30' (9.14 m) lengths; 48" x 48" (1.22 m x 1.22 m) wide. Appropriate length pairs of pendants with each extension.

Boom connections — In-line pin connections.

Boom top section — Open throat; 20' (6.10 m) long.

Boompoint machinery — 18" (0.46 m) root diameter sheaves; mounted on anti-friction bearings. Three sheaves, standard; two or four, optional.

Boompoint sheave guards — Standard: rigid, round steel rod bolted over top of sheaves and rigid, round steel rods between sheaves.

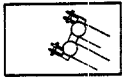

Boomhoist bridle and spreader bar

Serves as connection between boom pendants and boomhoist wire rope reeving. Bridle contains six 12" (0.30 m) root diameter sheaves — mounted on anti-friction bearings — for 12-part boomhoist reeving and two auxiliary hoist sheaves — mounted on bronze bushings — to facilitate using boom live mast as short boom.

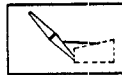

Boom stops

Dual, tubular lever type, with spring loaded bumpers.

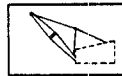

Boom live mast

Standard with tubular boom. Mounts on front of upper revolving frame; supports boomhoist bridle, spreader bar and boom midpoint suspension pendants. Mast hydraulically extended to 24' (7.32 m) minimum length; can be used as short boom for machine assembly/disassembly.

Maximum lifting capacity of mast at 20' (6.10 m) length is 15,200 lbs. (6 895 kg) from 9' 1 3/4" (2.78 m) minimum to 20' (6.10 m) maximum radius — with machine on outriggers.

Boom live mast stops — Spring cushioned bumpers are pinned to each main mast stop member for the boom live mast when used as short boom.

Boom midpoint suspension pendants — Standard equipment with boom live mast for tubular boom — must be used for boom lengths 110' (33.53 m) through 170' (51.82 m). Use is optional for shorter boom lengths.

Boom folding equipment — Optional; facilitates folding of pin-connected tubular boom. Two folding links, plus a shorter set of pendants, are inserted in boomhoist reeving to eliminate need for "breaking" boomhoist reeving to fold boom. Brackets for boom folding wheel strut mounting are welded to boom tip and wheel struts are attached with pins. Special 10' (3.05 m) pin-connected boom extension with lifting lugs and spoked wheel with 6:00 x 16, 14-ply rating, tire with tube are included.

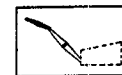

Tubular jib

Two-piece, basic jib — 20' (6.10 m) long; 24" (0.61 m) wide, 18" (0.46 m) deep at connections.

Base section — 10' (3.05 m) long; mounted to bracket welded on end of boom top section.

Jib extensions — Available in 10' (3.05 m) lengths for 30' or 40' (9.14 or 12.19 m) lengths.

Jib connections — Pin connections.

Jib tip section — 10' (3.05 m) long; single peak sheave 15 7/8" (0.40 m) root diameter, mounted on anti-friction bearings.

Item applicable to both booms and jibs

Load Hoist Rope Deflector Rollers — Furnished to minimize hoist rope chafing against top side of boom; rollers mounted on anti-friction bearings. Rollers required when third drum rope passes over crane boom. One roller furnished as standard equipment on boom top section with angle or tubular boom. Following are additional rollers recommended:

Angle boom — One for booms 50' (15.24 m) through 60' (18.29 m); two for 65' (19.81 m) through 80' (24.38 m) and three for 85' (25.91 m) through 100' (30.48 m) boom lengths.

Tubular boom — Two for booms 100' (30.48 m) through 120' (36.58 m) and three for 130' (39.62 m) through 170' (51.82 m) boom lengths.



Jib mast

10' (3.05 m) high, mounted on jib base section of either angle or tubular jib. Two deflector sheaves within the mast, mounted on anti-friction bearings, to guide jib load hoist rope (whipline). Equalizer sheaves provided for jib frontstay and backstay ropes.

Jib mast stops — Telescoping type, spring-loaded; pinned from jib mast to boom top section and from jib mast to jib base section.

Jib staylines — Front staylines are attached between top of jib mast and peak of jib. Appropriate length pendants are added to front staylines as jib length increases. Rear staylines are attached between top of jib mast and base of boom top section. Adjustment of rear stayline length determines jib angle to boom.

Auxiliary equipment

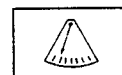

Boom angle indicator

Standard with either crane boom. Pendulum type mounted on left side of boom base section.

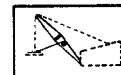

Fairlead

Optional: Full-revolving type with lock; barrel, sheaves, and guide rollers mounted on anti-friction bearings.

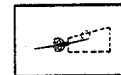

Tagline

Optional: Rud-O-Matic® model 648; spring wound drum type mounted on crane boom.

Load hoist wire ropes — Main load hoist wire rope standard. Jib load hoist wire rope (whipline) furnished with machine only if jib is ordered.

Hook blocks — Blocks, or weighted ball with swivel hook, optional — refer to price list.

Anti-two block warning device — **Optional:** available for main load hoist line, or main load hoist line and jib line.

Load moment device — **Optional:** audio/visual warning device for main load hoist line, or main load hoist line and jib line.

Maximum boom/jib lengths machine can lift off ground unassisted — without load

Standard Machine ① 15,200# Upper Cwt. "A" 2,000# Bumper Cwt.	On outriggers				On tires			
	Over rear		Over side		Over rear		Over side	
	Boom	Boom + Jib	Boom	Boom + Jib	Boom	Boom + Jib	Boom	Boom + Jib
Angle boom	100'	100' + 40'	100'	100' + 40'	—	—	—	—
Hi-Lite tubular boom w/boom live mast ②	170'	150' + 20'	160'	140' + 30'	110'	100' + 20'	100'	80' + 40'

Limited to 95% of backward stability.

Maximum boom/jib lengths machine can travel with at 5 m.p.h. speed — without load

Standard Machine ① 15,200# Upper Cwt. "A" 2,000# Bumper Cwt.	Over rear		Over side	
	Boom	Boom + Jib	Boom	Boom + Jib
Angle boom	90'	80' + 20'	—	—
Hi-Lite tubular boom w/boom live mast ②	110'	90' + 30'	90'	80' + 20'

Limited to 85% of backward stability.

① Lifting crane.

② Boom live mast fully extended in operating position.

Link-Belt® is a registered trademark.

We constantly improve our products and therefore reserve the right to change designs and specifications.

Link-Belt Construction Equipment Company Lexington, Kentucky

Link-Belt® HC-78B Performance Specifications

Wire rope and rope drum data

Main load hoist wire rope length — for booms using 5/8" (16 mm) diameter wire rope.

Parts of line	Boom length															
	30' (9.14 m)		40' (12.19 m)		50' (15.24 m)		60' (18.29 m)		70' (21.34 m)		80' (24.38 m)		90' (27.43 m)		100' (30.48 m)	
	Feet	meters	Feet	meters	Feet	meters	Feet	meters	Feet	meters	Feet	meters	Feet	meters	Feet	meters
1	85	25.91	95	28.96	115	35.05	135	41.14	155	47.24	175	53.34	195	59.43	215	65.53
2	125	38.10	140	42.67	170	51.81	200	60.96	230	70.10	260	79.24	290	88.39	320	97.53
3	165	50.29	185	56.38	225	68.58	265	80.77	305	92.96	345	105.15	385	117.34	425	129.54
4	205	62.48	230	70.10	280	85.34	330	100.58	380	115.82	430	131.06	480	146.30	530	161.54
5	245	74.67	275	83.82	335	102.10	395	120.39	455	138.68	515	156.97	575	175.26	635	193.54
6	285	86.86	320	97.53	390	118.87	460	140.20	530	161.54	600	182.88	670	204.21	740	225.55
7	325	99.06	365	111.25	445	135.63	525	160.02	605	184.40	685	208.78				
8	365	111.25	410	124.96	500	152.40	590	179.83	680	207.26						

Parts of line	Boom length													
	110' (33.53 m)		120' (36.58 m)		130' (39.62 m)		140' (42.67 m)		150' (45.72 m)		160' (48.77 m)		170' (51.82 m)	
	Feet	meters	Feet	meters	Feet	meters	Feet	meters	Feet	meters	Feet	meters	Feet	meters
1	235	71.62	255	77.72	275	83.82	295	89.91	315	96.01	335	102.10	355	108.20
2	350	106.68	380	115.82	410	125.96	440	134.11	470	143.25	500	152.40	530	161.54
3	465	141.73	505	153.92	545	166.11	585	178.30						
4	580	176.78	630	192.02	680	207.26								
5	695	211.83	755	320.12										

Note: Boom lengths beyond 100' (30.48 m) applicable to tubular boom only.

Jib load hoist wire rope lengths (whipline) — using 5/8" (16 mm) diameter wire rope.

Jib length	Parts of line	Boom length													
		35' (10.66 m)		40' (12.19 m)		50' (15.24 m)		60' (18.28 m)		70' (21.33 m)		80' (24.38 m)		90' (27.43 m)	
		Feet	meters	Feet	meters	Feet	meters	Feet	meters	Feet	meters	Feet	meters	Feet	meters
20' (6.10 m)	1	125	38.10	135	41.14	155	47.24	175	53.34	195	59.43	215	65.53	235	71.62
	2	185	56.38	200	60.96	230	70.10	260	79.24	290	88.39	320	97.53	350	106.68
30' (9.14 m)	1	145	44.19	155	47.24	175	53.34	195	59.43	215	65.53	235	71.62	255	77.72
	2	215	65.53	230	70.10	260	79.24	290	88.39	320	97.53	350	106.68	380	115.82
40' (12.19 m)	1	165	50.29	175	53.34	195	59.43	215	65.53	235	71.62	255	77.72	275	83.82
	2	245	76.67	280	85.34	290	88.39	320	97.53	350	106.68	380	115.82	410	124.96

Jib length	Parts of line	Boom length											
		100' (30.48 m)		110' (33.52 m)		120' (36.57 m)		130' (39.62 m)		140' (42.67 m)		150' (45.72 m)	
		Feet	meters	Feet	meters	Feet	meters	Feet	meters	Feet	meters	Feet	meters
20' (6.10 m)	1	255	77.72	275	83.82	295	89.91	315	96.01	335	102.10	355	108.20
	2	380	115.82	410	124.96	440	134.11	470	143.25	500	152.40	530	161.54
30' (9.14 m)	1	275	83.82	295	89.91	315	96.01	335	102.10	355	108.20		
	2	410	124.96	440	134.11	470	143.25	500	152.40	530	161.54		
40' (12.19 m)	1	295	89.91	315	96.01	335	102.10	355	108.20				
	2	440	134.11	470	143.25	500	152.40	530	161.54				

Note: Boom lengths beyond 100' (30.48 m) applicable to tubular boom only.

HC-78B performance specifications

Wire rope and rope drum data — (continued)

Boomhoist wire rope lengths

Parts of line	Angle boom		Tubular boom with boom live mast	
	Feet	meters	Feet	meters
8	240	73.15	—	—
10	315	96.01	—	—
12	355	108.20	430	131.06

Dragline wire rope lengths

	Parts of line	Boom length							
		35' (10.66 m)		40' (12.19 m)		45' (13.71 m)		50' (15.24 m)	
		Feet	meters	Feet	meters	Feet	meters	Feet	meters
Inhaul Hoist	1	46	14.02	52	15.85	58	17.68	64	19.51
	1	85	25.91	95	28.96	105	32.00	115	35.05

Clamshell wire rope lengths

	Parts of line	Boom length							
		35' (10.66 m)		40' (12.19 m)		45' (13.71 m)		50' (15.24 m)	
		Feet	meters	Feet	meters	Feet	meters	Feet	meters
Holding Closing	1	95	28.96	105	32.00	115	35.05	125	38.10
	1	130	39.62	140	42.67	150	45.72	160	48.77

Drum wire rope capacities; line speed and pull — (Available line pull, not based on wire rope strength).

Attachment	Wire rope diameter		Front drum														
			Lagging			Line speed and pull								Drum capacity			
			Root diameter		Type	First layer rope				Full drum rope				First layer		Full drum	
			In.	m		F.p.m.	m/min.	Lbs.	kg	F.p.m.	m/min.	Lbs.	kg	Ft.	m	Ft.	m
Crane	5/8	16	12	3.66	Smooth	147 250	44.81 76.20	17,220 9,560	7 801 4 336	235 400	71.63 121.92	10,800 6,000	4 898 1 814	57	17.37	543	165.51
Clamshell	3/4	19	14	4.27	Grooved	173 294	52.73 89.61	14,720 8,170	6 676 3 705	243 413	74.07 125.88	10,480 5,820	4 917 2 639	49	14.94	319	97.23
Dragline	3/4	19	12	3.66	Grooved	150 255	45.72 77.72	17,080 9,480	7 747 4 300	237 403	72.24 122.83	10,740 5,960	4 871 2 703	43	13.11	354	107.90

Attachment categories: First line — Standard drum
 Second line — High speed, planetary driven drum

HC-78B performance specifications

Wire rope and rope drum data — (continued)

Drum wire rope capacities; line speed and pull — (Available line pull, not based on wire rope strength).

Attachment	Wire rope diameter		Rear drum															
			Lagging			Line speed and pull										Drum capacity		
	Root diameter		Type	First layer rope				Full drum rope				First layer		Full drum				
	In.	mm		In.	m	F.p.m.	m/min.	Lbs.	kg	F.p.m.	m/min.	Lbs.	kg	Ft.	m	Ft.	m	
Crane	5/8	16	12	3.66	Smooth	147	44.81	16,700	7 575	235	71.63	10,480	4 917	57	25.86	543	246.30	
						250	76.20	9,270	4 204	400	121.92	5,820	2 639					
Clamshell	3/4	19	14	4.27	Grooved	173	52.73	14,320	6 495	241	73.46	10,180	4 617	49	14.94	319	97.23	
						294	89.61	7,950	3 606	410	124.97	5,650	2 562					
Dragline	3/4	19	14	4.27	Grooved	173	52.73	14,320	6 495	241	73.46	10,180	4 617	49	14.94	319	97.23	
						294	89.61	7,950	3 606	310	124.97	5,650	2 562					

Attachment categories: First line — Standard drum
Second line — High speed, planetary driven drum

Drum wire rope capacities; line speed and pull — (Available line pull, not based on wire rope strength).

Wire rope diameter	Third drum															
	Lagging			Line speed and pull										Drum capacity		
	Root diameter		Type	First layer rope				Full drum rope				First layer		Full drum		
	In.	mm		In.	m	F.p.m.	m/min.	Lbs.	kg	F.p.m.	m/min.	Lbs.	kg	Ft.	m	Ft.
5/8	15.88	9	2.74	Grooved	113	34.44	10,000	4 536	185	56.99	6,000	2 721	33	10.06	278	84.73
		11	3.35	Grooved	136	41.45	8,200	3 719	180	54.86	6,200	2 812	40	12.19	195	59.44

Drum wire rope capacities; line speed and pull

Wire rope diameter	Boomhoist drum															
	Lagging			Line speed and pull										Drum capacity		
	Root diameter		Type	First layer rope				Full drum rope				First layer		Full drum		
	In.	mm		In.	m	F.p.m.	m/min.	Lbs.	kg	F.p.m.	m/min.	Lbs.	kg	Ft.	m	Ft.
5/8 [ⓐ]	15.88	9	2.74	Grooved	127	38.71	20,000	9 072	242	73.76	10,470	4 749	16	4.88	215	65.53
1/2 [ⓑ]	12.70	9	2.74	Grooved	125	38.10	20,250	9 185	244	74.37	10,400	4 717	21	6.40	346	105.46

ⓐ Angle boom ⓑ Tubular boom

HC-78B performance specifications

Rope size and type

Wire rope application	Type and size used
Boomhoist	5/8" (16 mm) diameter, Type "N"
Main load hoist	5/8" (16 mm) diameter, Type "N"
Jib load hoist (1 part)	5/8" (16 mm) diameter, Type "P"
Jib load hoist (2 part)	5/8" (16 mm) diameter, Type "F"
Third drum	5/8" (16 mm) diameter, Type "N"
Boom pendants	1 1/8" (29 mm) diameter, Type "N"
Boom midpoint suspension pendants	3/4" (19 mm) diameter, Type "F"
Jib frontstay line	5/8" (16 mm) diameter, Type "F"
Jib backstay line	5/8" (16 mm) diameter, Type "F"
Dragline inhaul	3/4" (19 mm) diameter, Type "D"
Dragline hoist	3/4" (19 mm) diameter, Type "F"
Clamshell holding	5/8" (16 mm) diameter, Type "F"
Clamshell closing	5/8" (16 mm) diameter, Type "F"

Wire rope types

Type "D" — 6 x 25 (6 x 19 class), filler wire, improved plow steel, preformed, fiber center, right lay, regular lay.
Type "F" — 6 x 25 (6 x 19 class), filler wire, improved plow steel, preformed, independent wire rope center, right lay, regular lay.
Type "N" — 6 x 25 (6 x 19 class), filler wire, extra improved plow steel, preformed, independent wire rope center, right lay, regular lay.
Type "P" — 19 x 7 non-rotating, extra improved plow steel, preformed, wire center core.

Link-Belt® is a registered trademark.

We are constantly improving our products and therefore reserve the right to change designs and specifications.

Link-Belt Construction Equipment Company Lexington, Kentucky