



series SX

BOOM TRUCKS

features

- Max 30 ton (27,2 mton) Capacity
- 5-Section 124' (37,8 m) Proportional Boom
- 1-Piece 31' (9,5m) Jib
- 4-Section 102' (31,1 m) Proportional Boom
- 2-Section 26' (7,9 m) to 46' (14,0 m) Jib
- 164' (50 m) Maximum Tip Height
- 20' 5" (6,2 m) X-Style symmetrical Outrigger Spread
Optional ROCSolid handheld outrigger radio remote controller
- Pilot operated Controls with Optional Free Swing with ACCUSwing control
- 2-Speed Planetary Hoist with Grooved Drum, Negative Draft Flange and Cable Roller.
- Dual Load Chart for use with and without Counterweight.
- Load Moment Indicator with Digital Display, CAN Bus, Overload Shutdown and Internal Boom Length Cable
- Radio ATB
- Rugged, Weatherproof Electrical System with Circuit Status LEDs
- Removable Boom Rest
- System Pressure Gauge
- Continuous Rotation
- Clamp-On Mounting
- Optional Cab and Heater
- Self-Lubricating Boom Slider pads
- ManItex UPTIME Comprehensive Support



product guide

series SX

GENERAL SPECIFICATIONS

BOOM

Inverted T-cross section, 4 or 5-section telescoping type, extended and retracted proportionally by a double-acting hydraulic cylinder and cable-crowd system. Equipped with easily replaceable teflon-plugged nylatron wear pads for smooth operation.

102SX - 4-Section 29' 9" (9,1 m) to 102' (31,1 m). 2-Section, 26' (7,9 m) to 46' (14,0 m) jib.

124SX - 5-section 30'10" (9,4 m) to 123'6" (37,6m). 1-Section, 31' (9,5 m) jib.

Quick Reeve Boom Point – Five high-density nylon load sheaves mounted on heavy-duty roller bearings. Two removable pin-type rope guards.

Boom Elevation – Double-acting hydraulic cylinder. Working range from 6° below horizontal to 80° above.

Load Hook – 5-ton (4,5 mton) capacity hook with heavy-duty swivel and weight is provided for single-line operation.

HOIST

102SX - Maximum theoretical line speed 300 fpm (91 mpm). Maximum theoretical bottom-layer line pull 11,500 lb (5 216 kg). Two-speed planetary reducer with wet multi-disc spring applied, pressure-released internal brake and grooved drum.

Wire Rope - 335' (102,1 m) of 9/16" (14,3 mm) diameter rotation resistant type.

124SX - Maximum theoretical line speed 453 fpm (138 mpm). Maximum theoretical bottom-layer line pull 13050 lb (5 919 kg). Two-speed planetary reducer with wet multi-disc spring applied, pressure-released internal brake and grooved drum.

Wire Rope – 380' (115,8 m) of 5/8" (16 mm) diameter rotation resistant type.

SWING SYSTEM

Ball-bearing swing circle with external gear. Continuous rotation is standard. Manitex ACCUSwing control allows operator to adjust crane swing speed up to a maximum of 2.0 rpm (nominal).

Free Swing - equipped with externally mounted, double-reduction planetary gearbox driven by hydraulic motor. Dual brake system features a spring-applied hydraulically-released Parking Brake and a foot actuated Dynamic Service Brake.

No-Free Swing - equipped with externally mounted, double-reduction planetary gearbox driven by hydraulic motor. Features a wet multi-disc, spring-applied, hydraulically-released brake.

OUTRIGGERS

Patented X-style outrigger provides all around stability to create a true 360° work zone without need of a front mounted stabilizer. Design incorporates double-acting hydraulic cylinders; operated independently for precise leveling. Bubble level located near outrigger controls. Optional ROCSolid handheld radio remote control for outriggers is available for ease of crane set-up.

MOUNTING

Lower frame is mounted to chassis by threaded rods and clamp plates. No welding to truck chassis is required.

Rear Underride Protection – Supplied on factory mounted cranes. Fabricated structure mounted at rear of carrier. Complies with Bureau of Motor Carrier Safety Standard 393.86.

Lower Frame – Torsion resistant, rigid welded plate design with integrated pedestal.

Boom Rest – Heavy-duty fabrication. Easily removed to simplify loading and unloading truck deck.

CONTROL SYSTEM

Single operator platform and seat mounted to turret. Four "pilot operated" single-axis crane controls provide precise metering and multifunction capability. Controls are arranged in accordance with ANSI B30.5 standards. The operator station also includes engine start/stop, air foot throttle, signal horn, load moment indicator display, boom angle indicator, load chart and range diagram. Enclosed cab and heater are optional.

HYDRAULICS

Hydraulic System – A 3-section pump direct-mounted to power take-off on truck transmission provides 41.7 gpm (158 lpm) to the hoist, 28 gpm (106 lpm) to the boom hoist, telescope and outrigger circuit, and 12 gpm (45 lpm) to the swing circuit. 100-gallon (379 liter) hydraulic reservoir with strainer and a 10-micron filter in the return line. Ball-type shutoff valve and strainer are provided in suction line. Use of SAE O-ring and face seal O-ring hydraulic fittings throughout system.

Hydraulic Cylinders – All load-holding cylinders are equipped with integral holding valves.

WARNING SYSTEMS

Load Moment Indicator (LMI) – CAN bus system maximize expansion capabilities. Senses boom hoist cylinder pressure, boom length and boom angle. Audio-visual warning indicates overload conditions and overload shutoff feature prevents continuing overload. Operator can access all load conditions via display at the operator station. Internal boom length cable.

Radio Anti-Two-Block System – Audible warning and shutoff functions prevent hook from contacting boom point.

Back-Up Alarm – Electronic audible motion alarm activated when truck transmission is in reverse gear.

GENERAL

Electrical – State-of-the-art, weather-resistant components throughout. Hermetically sealed power in relays. Enclosure includes power in relays and circuit status LEDs. Designed to withstand high pressure washing and varying climates.

Design/Welding – Design conforms to ANSI B30.5. Welding conforms to AWS D1.1. Tested to SAE 1063 and SAE 765.

Manuals – Operator, service and parts manuals depict correct crane operation, maintenance procedures and parts listing.

Warranty – 12-month warranty covers parts and labor resulting from defects in material and workmanship.

* In order to ensure continuous improvement, specifications may change without notice.

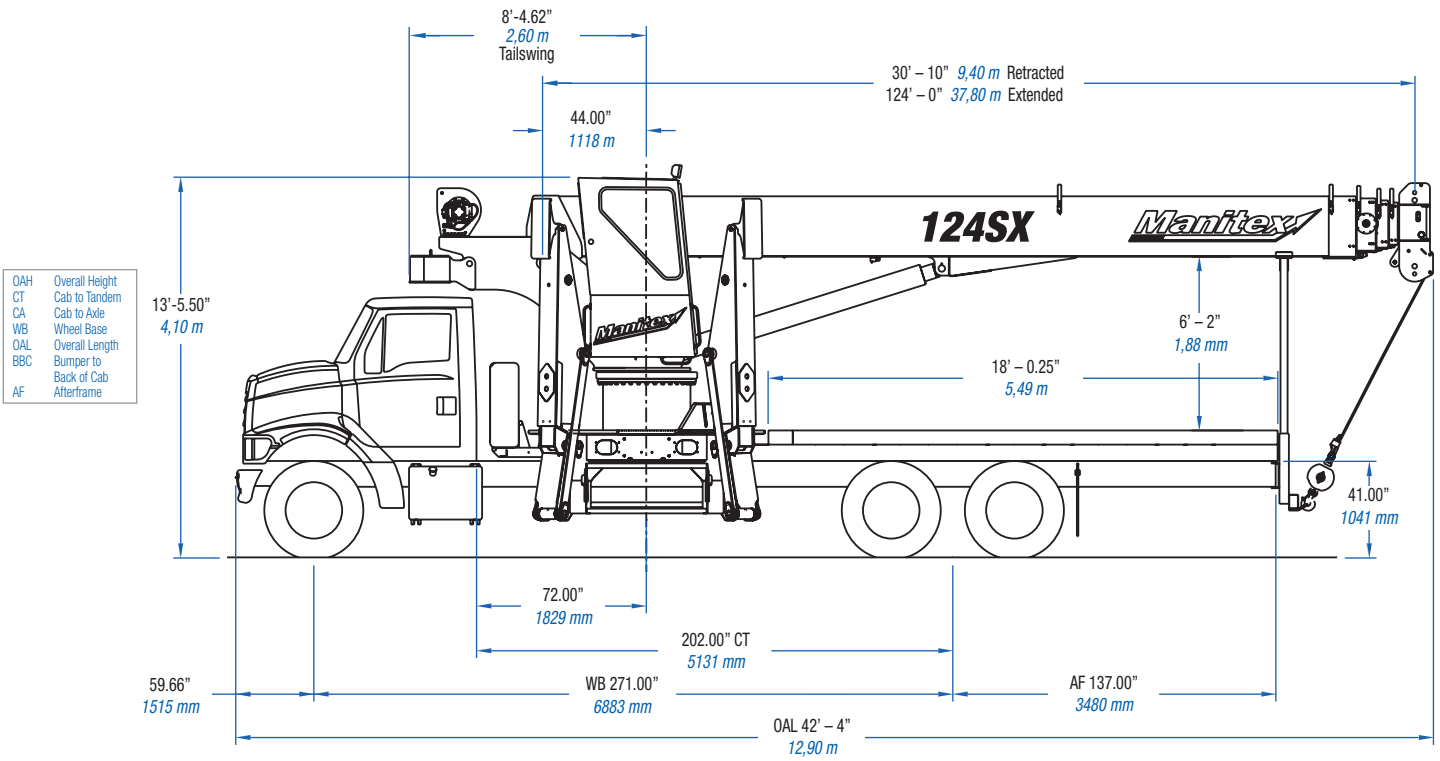

OAH Overall Height
 CT Cab to Tandem
 CA Cab to Axle
 WB Wheel Base
 OAL Overall Length
 BBC Bumper to Back of Cab
 AF Afterframe

CHASSIS DATA	SX Series
Wheelbase (WB)	271" 6 883 mm
Cab to Tandem (CT)	202" 5 131 mm
Cab to End of Frame (EOF)	339" 8 610 mm
Frame Section Modulus	30.0 in³ 110,000 psi 758 422 kPa
Front Axle Gross Weight Rating	20,000 lb 9 072 kg
Rear Axle Gross Weight Rating	40,000 lb 18 144 kg
Minimum Truck Axle Weight - Front**	8,500 lb 3 856 kg
Minimum Truck Axle Weight - Back**	8,545 lb 3 876 kg
Nominal Frame Width	34" 864 mm

**Minimum chassis weight is required to meet 85% stability requirements. Chassis data is general – not for engineering. Some dimensions depend on truck selection.

MAXIMUM TIP HEIGHT	102SX	124SX
Configuration	Boom 102' 31,1 m	Boom 124' 37,8 m
Extended Boom	110' 6" 33,7 m	132' 8" 40,4 m
Fixed or Retracted Jib	136' 10" 41,7 m	164' 0" 50 m
Extended Jib	156' 6" 47,7 m	—

WEIGHTS	102SX	124SX
Cab Alone	575 lb 261 kg	575 lb 261 kg
Crane (Without Cab)	28,325 lb 12 848 kg	33,623 lb 15 251 kg
17' (5,18 m) Flat Bed	1,700 lb 771 kg	1,700 lb 771 kg
26' (7,92 m) Fixed Length Jib	832 lb 378 kg	—
26' (7,92 m) to 46' (14,02 m) Telescopic Jib	1,226 lb 557 kg	—
31' (9,45 m) Fixed Length Jib	—	850 lb 386 kg

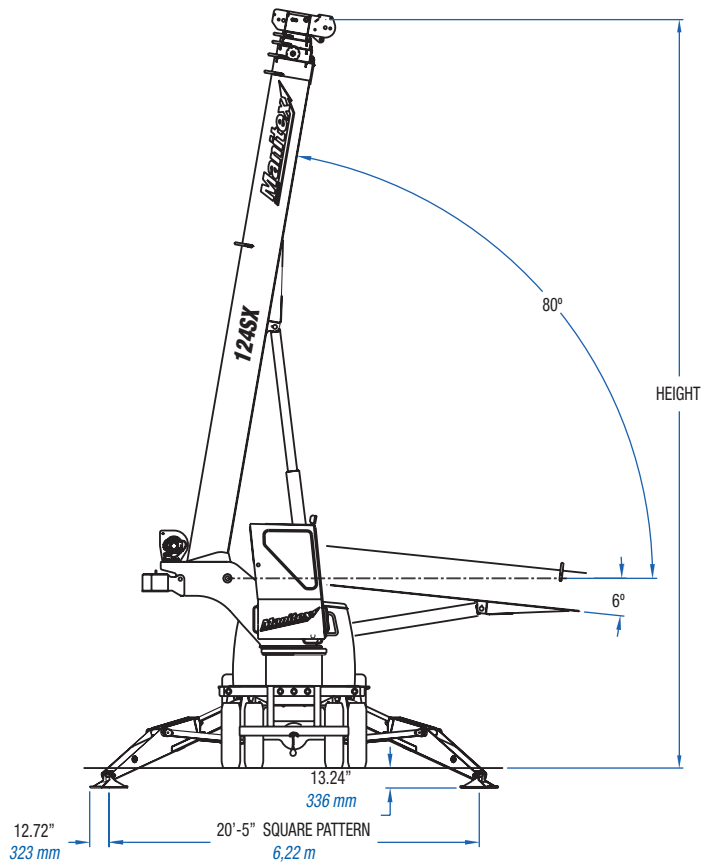

USE THIS CHART ONLY WHEN COUNTER WEIGHT IS INSTALLED.

Counterweight must be installed for this load chart

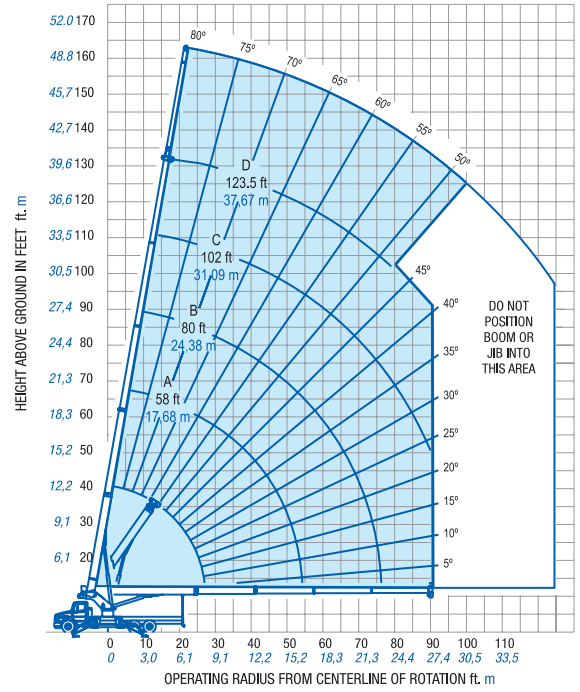
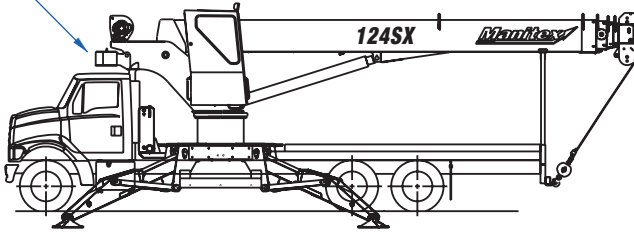

FULLY EXTENDED OUTRIGGER SPREAD: MODEL 124SX

MAIN BOOM LOAD RATINGS

JIB

Operating Radius	Boom Length		A		B		C		D		Fixed Jib						
	30.8 Feet 9,39 Meters	58 Feet 17,68 Meters	80 Feet 24,38 Meters	102 Feet 31,09 Meters	123.5 Feet 37,64 Meters	31 Feet 9,45 Meters											
Feet	Meters	∠	lb.	kg.	∠	lb.	kg.	∠	lb.	kg.	∠	lb.	kg.	∠	lb.	kg.	
5	1,52	75	60,000	27 216													
8	2,44	69	46,500	21 092													
10	3,05	64	40,000	18 144													
12	3,66	60	35,000	15 876	75	25,000	11 340										
15	4,57	53	29,000	13 154	73	25,000	11 340	79	21,500	9 752							
20	6,10	40	22,130	10 038	67	22,740	10 315	75	19,700	8 936	80	14,500	6 577				
25	7,62	22	16,330	7 407	62	17,250	7 824	71	17,460	7 920	77	13,500	6 123	80	8,450	3 833	
30	9,14				56	13,430	6 092	67	13,650	6 192	74	12,820	5 815	78	8,150	3 697	
35	10,67				49	10,700	4 853	63	10,920	4 953	71	11,020	4 999	75	7,800	3 538	
40	12,19				42	8,640	3 919	59	8,870	4 023	68	8,980	4 073	72	7,280	3 302	
45	13,71				34	7,030	3 189	54	7,280	3 302	65	7,390	3 352	70	6,780	3 075	
50	15,24				23	5,730	2 599	50	6,000	2 722	61	6,110	2 771	67	6,160	2 794	
55	16,76							44	4,880	2 214	58	5,020	2 277	65	5,090	2 309	
60	18,28							39	3,920	1 778	54	4,050	1 837	62	4,120	1 869	
65	19,81							32	3,120	1 415	50	3,260	1 479	59	3,330	1 510	
70	21,34							24	2,450	1 111	46	2,600	1 179	56	2,680	1 216	
75	22,86							12	1,870	848	42	2,050	930	53	2,120	962	
80	24,38										37	1,560	708	50	1,640	744	
85	25,91										32	1,150	522	47	1,230	558	
90	27,43										25	780	354	43	860	390	
95	28,96																
100	30,48																
			450 lbs 204 kg			240 lbs 109 kg			180 lbs 82 kg			140 lbs 64 kg			120 lbs 54 kg		DEDUCTIONS FOR STOWED JIB

Meets ANSI B30.5 Requirements - Do not operate crane or accessories within 10' (3,05m) of live power lines.
 NOTICE: This chart is for reference only and must not be used for lifting purposes. Consult factory for other boom options.

AREA OF OPERATION

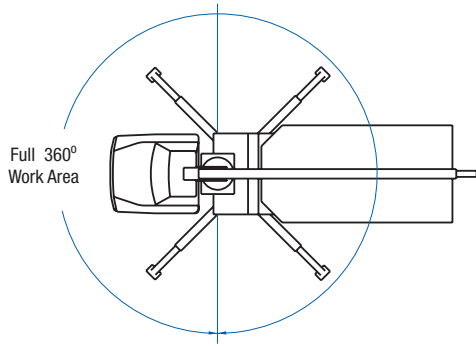

DEDUCTIONS

Auxiliary Block	50 lb 22,72 kg
Load Block	See block manufacturer nameplate
Overhaul Ball	See overhaul ball manufacturer nameplate
Swing Around Jib (Stowed)	See load rating chart

ALLOWABLE LINE PULL

1 Part Line	2 Part Line	3 Part Line	4 Part Line	5 Part Line	6 Part Line	7 Part Line	WARNING
							<p>Anti-two-block system must be in good operating condition before operating crane.</p> <p>Refer to the owner's manual.</p> <p>Keep at least three wraps of load line on the drum at all times.</p>
9,080 lb 4 119 kg	18,160 lb 8 237 kg	27,240 lb 12 356 kg	36,320 lb 16 474 kg	45,400 lb 20 593 kg	54,480 lb 24 712 kg	60,000 lb 27 216 kg	
9,500 lb 4 309 kg	19,000 lb 8 618 kg	28,500 lb 12 927 kg	38,000 lb 17 237 kg	47,500 lb 21 546 kg	57,000 lb 25 855 kg	60,000 lb 27 216 kg	
<small>NOTE: Table does not apply to model 102SX, for 102SX line pull information consult factory.</small>							

BOOM AND JIB COMBINATIONS

102SX	102'	4 Section Boom	26' – 46' 2 - Section Jib
124SX	124'	5 Section Boom	31' 1 - Section Jib

UPTime is the Manitex commitment to complete support of thousands of units working every day.

UPTime

- Includes 24-7-365 parts assistance.
- Utilizes the efficiency of the Manitex Online Parts Search and Order System..
- Relies on Manitex's UPTrak support tracking system for performance analysis and resource allocation.
- Features REMan, Manitex's cost effective rebuild/exchange program.
- Provides expert service technicians for troubleshooting and site visits.
- Mandates training; at our facility and yours. It includes coordinated support from all component suppliers.
- Involves every Manitex team member in the support of every Manitex customer.

What does UPTime mean to Manitex customers?

UPTime means reliability.

UPTime means utilization.

UPTime means profitability.



Manitex
3000 South Austin Avenue
Georgetown, TX, USA 78626
Telephone 512-942-3000
Facsimile 512-863-3776
www.manitex.com