

Specifications

Hydraulic Rough Terrain Crane

GENERAL INFORMATION ONLY

HSP-8050

50 Ton (45.36 metric ton)

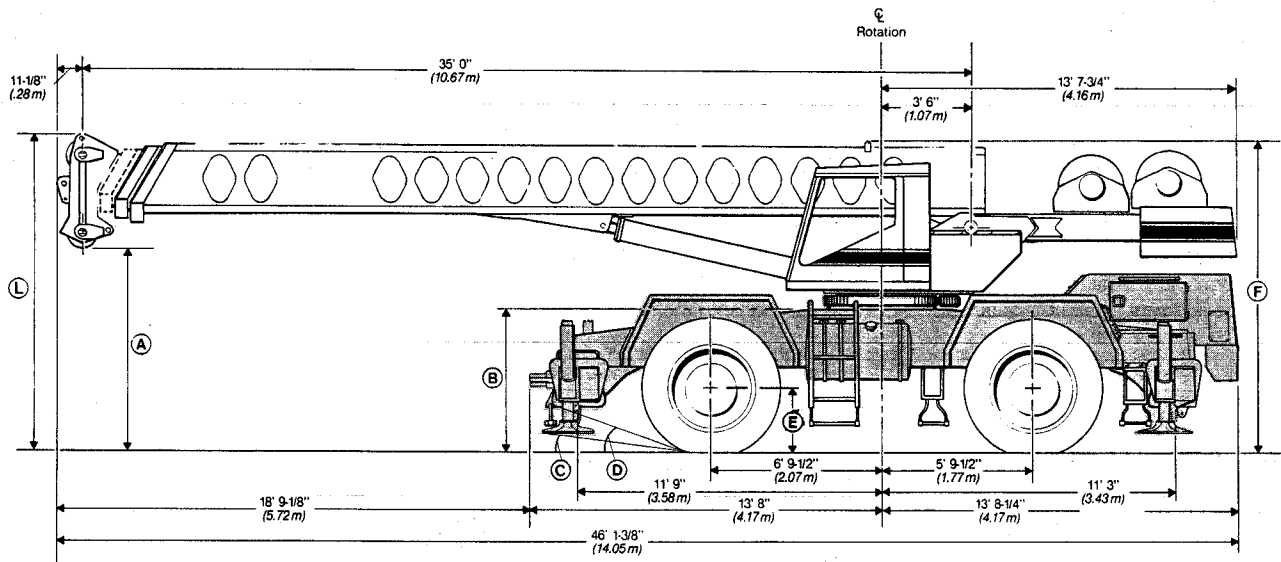

Not to Scale

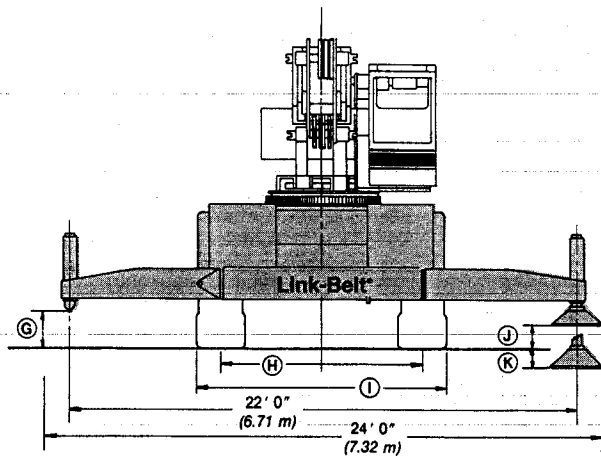

Not to Scale

General dimensions	feet	meters
Turning radius (4-wheel steer)	25'	7.62
Tailswing of counterweight	13' 8-5/8"	4.18

Dimensions affected by tires

Tires	26.5 x 25(24-PR)		29.5 x 25 (22-PR)	
	feet	meters	feet	meters
A	7' 9-1/4"	2.37	7' 10-3/4"	2.41
B	5' 9-1/2"	1.77	5' 11"	1.80
C	9"	—	10 97"	—
D	22°	—	24 5"	—
E	2' 6-3/8"	.77	2' 8"	.81
F	12' 2-1/2"	3.72	12' 4"	3.70
G	1' 7-3/4"	.50	1' 9-5/16"	0.54
H	8' 6-1/2"	2.60	8' 2-1/2"	2.50
I	10' 10"	3.30	10' 9-1/2"	3.28
J	9-3/4"	.25	11-5/16"	.29
K	10"	.25	7-9/32"	.18
L	12' 6-3/4"	3.83	12' 8-1/4"	3.80

Upperstructure

■ Boom

Patented design. Boom side plates have diamond shaped impressions for superior strength to weight ratio and 100,000 psi (689.5 MPa) steel angle chord for lateral stiffness. Boom sections are supported by wear shoes both vertically and horizontally. Anti two block, electronic boom length / angle indicator and function kickout.

Load Moment Indicator — Audio-visual warning system with anti-two block and function kickouts. Constant display of boom length and angle, tip height, radius of load, machine configuration, allowed load, actual load and % of allowed load. Presettable alarms for maximum and minimum boom angles, maximum tip height and maximum boom length.

Standard boom — 35' 0" - 85' 0" (10.67 m - 25.91 m) 3-section full power boom.

Optional boom — 35' 0" - 110' 0" (10.67 m - 33.53 m) 4-section boom includes base section, two power sections, and manual fourth section. Fourth section is power pinned by manually activating a cylinder locking system.

Boom head — **Standard;** Four 16-3/8" (0.42 m) root diameter head sheaves with five 16-3/8" (0.42 m) available to handle up to 10 parts of wire rope. Two easily removable wire rope guards; rope dead end lugs provided on each side of boom head.

Auxiliary lifting sheave — *Optional;* Single 16-3/8" (0.42 m) root diameter head sheave with removable wire rope guard, mounted to boom, for use with one or two parts of line off the optional auxiliary winch. Does not affect erection of fly or jib, or use of main head sheave for multiple reeving.

Boom elevation — Two hydraulic cylinders with holding valves. Self aligning steel bushings. Hand and optional foot controls for controlling the boom elevation from -3° to 78°.

■ Fly

Optional — 33' 0" (10.06 m) stowable one-piece lattice type.

■ Jib

Optional — 25' 0" (7.62 m) stowable A-frame which can be offset 5°, 17.5°, and 30°. Attaches to fly only.

■ Cab and Controls

Environmental cab; isolated from sound and vibration by a neoprene seal. All windows are tinted and tempered safety glass. Sliding rear and right side windows and swing up roof window for maximum visibility and ventilation. Slide-by-door opens to 3' 0" (0.91 m) width. 6-way adjustable operator's seat. 4-way adjustable tilt/telescoping steering wheel. Control levers for swing, boom telescope, winch and boom hoist with foot control swing brake. Outrigger controls, sight level bubble. Optional foot control for boom hoist.

■ Cab instrumentation

Dash mounted gauges for hydraulic oil temperature, converter temperature, oil pressure, water temperature, fuel and voltmeter.

■ Swing

Bi-directional hydraulic swing motor mounted to a planetary reducer for 360° continuous smooth swing at 2.45 r.p.m.

Swing brake — **Standard;** foot operated, spring released disc brake mounted on the speed reducer.

Swing lock — **Standard;** 360° position pin type and a two position travel lock operated from the operator's cab.

■ Counterweight

Pinned to upperstructure frame.

■ Hydraulic System

Main pump — Triple gear-type pump. Combined pump capacity 161 gpm (609.4 lpm). Powered by torque converter through a pump disconnect. Pump disconnect is a jaw-type clutch engaged/disengaged from carrier. Maximum system pressure at 2900 p.s.i. (199.94 Bars).

Steering/outrigger pump — Single gear-type pump, 28 gpm (106 lpm) maximum. Powered by torque converter through a straight mechanical drive. Pump operates at 2,700 p.s.i. (186.25 bars).

■ Reservoir

140 gallon (530.0 L) capacity. Diffusers for deaeration.

Filtration — One six-micron filter located inside the hydraulic reservoir. Accessible for easy replacement.

Control valves — Six separate control valves allow simultaneous operation of all crane functions.

■ Load Hoist System

Standard — Model 2M main winch with two-speed motor and automatic brake; power up/power down mode of operation. Bi-directional gear type hydraulic motor.

Optional — Model 2M auxiliary winch with two-speed motor and automatic brake, power up/power down mode of operation. Bi-directional, gear-type hydraulic motor.

Optional — Model 3M winch with power up/power down, two-speed motor and exclusive controlled true gravity free fall. Available on main winch only.

Line pulls and speeds — Maximum line pull 15,870 lbs. (7 199 kg) and maximum line speed 548 f.p.m. (167.03 m/min.) on 17" (0.43 m) root diameter smooth drum.

■ Additional Equipment - Standard

Rear view mirrors, seat belt, fire extinguisher, backup alarm, travel lights and sound suppressed cab.

■ Additional Upperstructure Equipment - Optional

Propane heater, diesel heater, air conditioning, drum rotation indicators, 60-ton (54.43 metric ton) hook block, 8-1/2 ton (7.71 metric ton) hook ball and swivel, rear steer indicator, boom mounted working light, engine monitoring system, top hatch wiper, windshield washer, hand throttle, lifting lugs, tachometer, amber rotating beacon, cab spotlight and boomhoist foot control.

GENERAL INFORMATION ONLY

Carrier

Type

10' 10" (3.30 m) wide, 151" (3.84 m) wheelbase.

4 x 4 x 4 — (4-wheel steer, 4-wheel drive)
Standard; for rough terrain with limited turning area.

4 x 4 x 4 — (4-wheel steer, 4-wheel drive)
Optional; no spin differential on front axle; for rough terrain with limited turning area.

Frame - 100,000 p.s.i. (689.5 MPa) steel, double walled construction with integral 100,000 p.s.i. (689.5 MPa) steel outrigger boxes.

Axles

Front, Standard — heavy duty planetary drive/steer type.

Rear, Standard — heavy duty planetary drive/steer type.

Front, Optional — heavy duty no-spin high traction differential, planetary drive/steer type.

Suspension

Front axle - Rigid mounted to frame.

Rear axle - Pin-mounted on bronze bushings. automatic hydraulic rear axle oscillation lock-out cylinders engage when upperstructure rotates past 2-1/2° of centerline.

Tires

Front and rear
Standard — 26.5 x 25 (24-PR)
Earthmover type

Optional — 29.5 x 25 (22-PR)
Earthmover type

Brakes

Service — Air over hydraulic, drum-type brakes at each wheel end. Drum diameter 20-1/4" (0.51 m). Shoe width 4" (101.6 mm).

Parking/emergency — Disc caliper type spring applied, air released, fade resistant; cab controlled, mounted on front axle.

Steering

Hydraulic two wheel, four wheel and "crab" steering.

Transmission

3-speed, 2-range power shift transmission. Six speeds available forward and 2 reverse. Front axle disconnect for two or four-wheel drive.

Outriggers

Four hydraulic, beam and jack outriggers. Vertical jack cylinders equipped with integral holding valve. Beams extend to 22' 0" (6.71 m) centerline-to-centerline and retract to within 10' 10" (3.30 m) overall width with floats stored. Equipped with stowable, lightweight 24" (0.61 m) diameter floats. Controls and sight level bubble located in upperstructure cab.

Additional Equipment - Standard

Cab steps, 2 front carrier steps, skid resistant finish on carrier deck, storage compartment and fenders.

Additional Equipment - Optional

Towing shackles, ether injection, no-spin differential on front axle, spare tires and rims, pintle hook, jack cylinder hose covers, propane fired engine block heater, air dryer and emergency steering system.

Travel Speeds and Gradeability

Engine	Tires	Maximum Speed		Gradeability at stall	Maximum tractive effort at stall		Gradeability at 1.0 mph (1.61 km/h)	Maximum tractive effort at 1.0 mph (1.61 km/h)	
		mph	km/h		pounds	kg		pounds	kg
GM 6V-53N	26.5 x 25	21	33.79	168%	79,145	35 900	55%	45,499	20 638
	*29.5 x 25	21	33.79	147%	76,177	34 554	52%	43,793	19 865
Cummins 6CT 8.3*	26.5 x 25	21	33.79	254%	85,551	38 806	62%	49,304	22 364
	*29.5 x 25	21	33.79	200%	82,343	37 351	59%	47,455	21 526

* Optional Equipment

Engine	GM 6V-53N	Cummins 6CT 8.3*
Cylinders - cycle	6 - 2	6 - 4
Bore	3-7/18" (98.43 mm)	4.49" (114.05 mm)
Stroke	4-1/2" (114.30 mm)	5.32" (135.13 mm)
Displacement	318 cu. in. (5 211 cm ³)	504 cu. in. (8 259 cm ³)
Compression ratio	21:1	17.3 : 1
Maximum brake h.p.	205 at 2700 r.p.m.	215 at 2700 rpm
Idle speed	500 r.p.m.	600 r.p.m.
Peak torque	445 lbs.	567 ft. lbs. at 1500 rpm
Electrical system	12 volt negative ground	12 volt negative ground
Fuel capacity	100 gallons (378.5 L)	100 gallons (378.5 L)
Alternator	80 amp Delco	80 amp Delco
Crankcase capacity	18.4 quarts (17.41 L)	18.9 quarts (17.89 L)
Air compressor	12 c.f.m. (0.34 m ³ /min)	13.2 c.f.m. (0.37 m ³ /min)

* Optional Equipment

GENERAL INFORMATION ONLY

Axle Loads

Base machine with standard 35'-85' (10.67 m-25.91 m) 3-section boom, main winch with 2-speed hoisting and power up/down, 600' (182.88 m) 3/4" (19 mm) wire rope, 4 x 4 x 4 carrier with GM 6V-53N engine, 26.5 x 25 tires, full fuel, rear counterweight, 4-sheave head machinery.	GVW [Ⓞ]		Upper facing front				Upper facing rear			
			Front axle		Rear axle		Front axle		Rear axle	
		lbs.	kg	lbs.	kg	lbs.	kg	lbs.	kg	lbs.
	77,988	34 044	34,690	15 732	40,378	18 312	28,292	12 831	46,776	21 214
35'-110' (10.67 m-33.52 m) 4-section boom	1,952	885	1,808	820	-1,057	-479	-1,212	-550	3,164	1 435
33' (10.06 m) lattice fly stowed	1,040	472	1,660	753	-620	-281	-703	-319	1,743	790
25' (7.62 m) A-frame jib stowed	1,128	512	1,438	652	-310	-141	-402	-182	1,530	694
Hook block at bumper	1,070	485	1,730	785	-660	-293	—	—	—	—
Headache ball at bumper	325	147	525	238	-200	-91	—	—	—	—
Auxiliary lifting sheave	150	68	468	212	-318	-144	-330	-150	480	218
Fly and jib stowage brackets	230	104	343	156	-113	-51	-132	-60	362	164
29.5 x 25 tires	160	72	80	36	80	36	—	—	—	—

[Ⓞ] Adjust gross vehicle weight and axle loading according to components weight.
Note: All weights are $\pm 3\%$.

Tire	Max. Axle Load @ 20 mph (32.7 km/hr)
26.50 x 25 (24-PR)	44,200 lbs. (20 047 kg)
29.50 x 25 (22-PR)	49,500 lbs. (22 451 kg)

GENERAL INFORMATION ONLY

• Link-Belt is a registered trademark.

We are constantly improving our products and therefore reserve the right to change designs and specifications.

Link-Belt Construction Equipment Company Lexington, Kentucky

A unit of Sumitomo Construction Machinery Co., Ltd.