

LIFTMOORE 208EL CRANE

8,100 FT.-LB. MOMENT RATING
2,000 LB. MAXIMUM CAPACITY.

- With its longer boom the 208EL is ideal for your light duty lifting where greater reach is required.
- A power elevation cylinder provides control of the load radius. An electric-hydraulic pump raises the boom angle from -5 to + 75 degrees. The boom is lowered by gravity with a velocity fuse for overrunning protection in case of hose failure.
- 360 degree Manual rotation is standard on the 208EL.
- A two section boom manually extends from 6 ft. to 14 ft, with an Intermediate position in both sections.
- The 208EL complies with OSHA standard 1910.180 including drum/wire ratios and SAE J1063 strain gage testing required by the OSHA standard.
- A load sensor is included as standard equipment to limit winch up and boom down.

Extension from 6-10-14 ft.

Sheave meets ANSI Standard

1/4" GAC wire rope

Downhaul Pickle Weight

Hook with safety latch

2000 Lb single line capacity Planetary Gear Winch

Power Boom Elevation

Model 208EL-14 Shown

Remote Pendant Control

Rotates on Tapered Roller Bearings

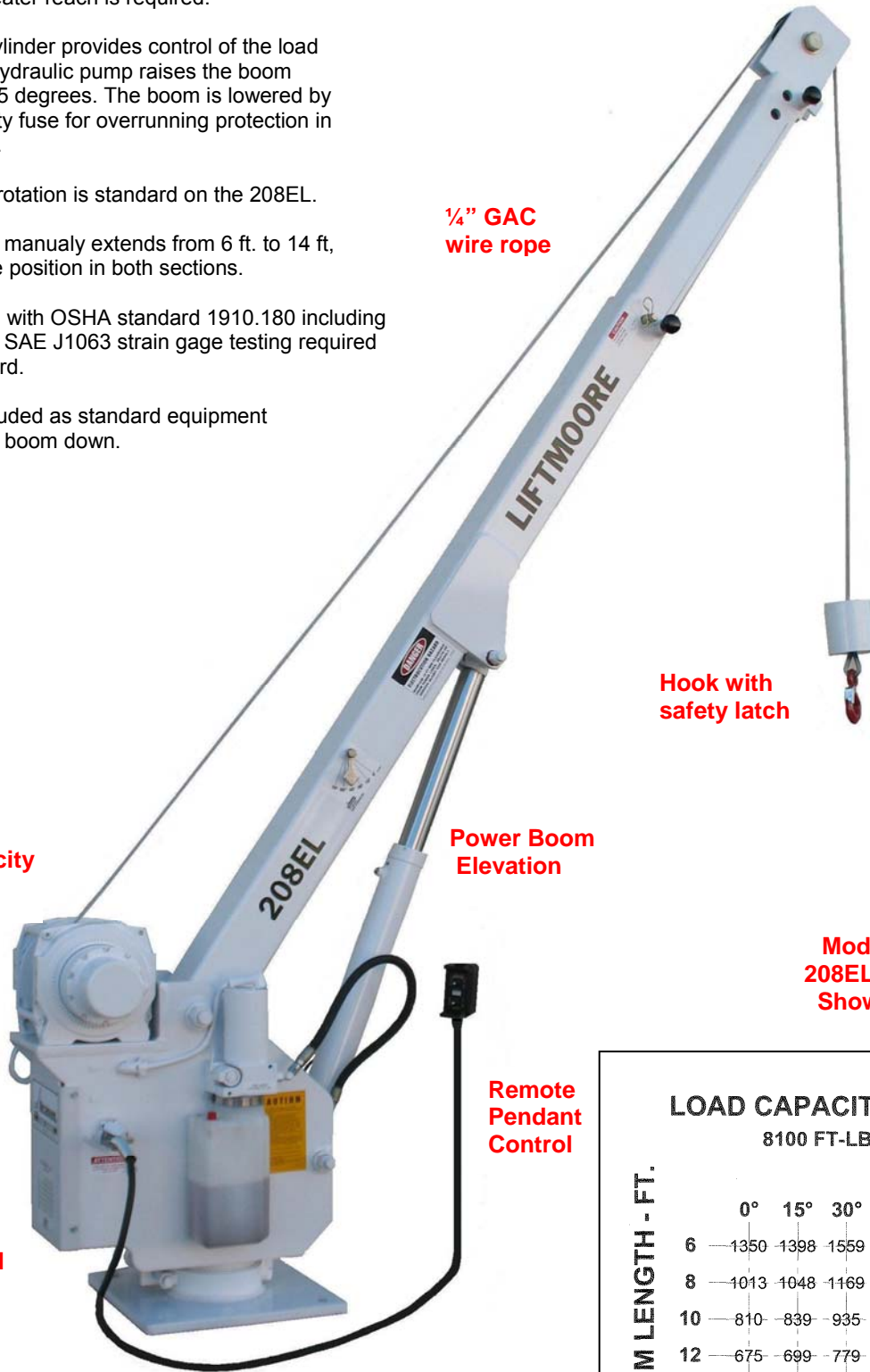

LOAD CAPACITY - LBS.

8100 FT.-LBS

BOOM LENGTH - FT.

	0°	15°	30°	45°	60°	75°
6	1350	1398	1559	1909	2000	2000
8	1013	1048	1169	1432	2000	2000
10	810	839	935	1146	1620	2000
12	675	699	779	955	1350	2000
14	579	599	668	818	1157	2000



HOUSTON, TEXAS
FAX: (800) 824-5559 (USA & Canada)
FAX: (713) 688-6324
PHONE: (713) 688-5533
www.liftmoore.com

713-688-5533
WWW.LIFTMOORE.COM

P/N 24609

208EL SPECIFICATIONS

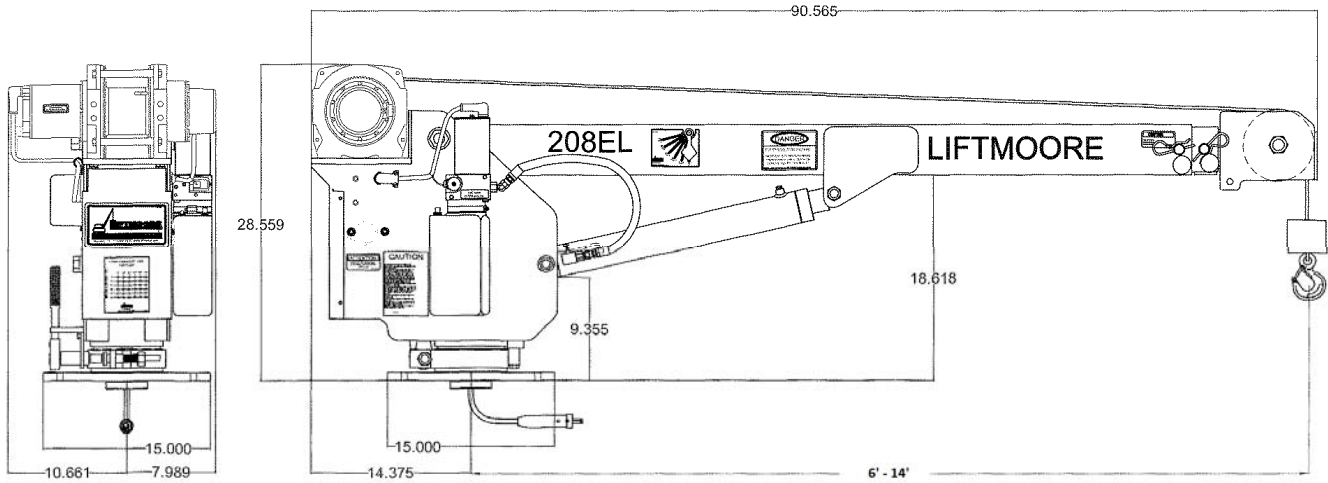

MOMENT RATING:
8,100 Ft.-Lbs.

LIFT CAPACITIES:
2000 Lbs. @ 4 Ft.
1350 Lbs. @ 6 Ft.
810 Lbs. @ 10 Ft.
579 Lbs. @ 14 Ft.

BOOM:
Two section manually extend boom from 6 ft. to 14 Ft.,
An intermediate position is provided in each section

Boom is elevated by a single acting hydraulic cylinder. Boom is lowered by gravity. Cylinder includes a velocity fuse for safety in the event of hose failure.

HOIST WINCH:
The hoist winch uses a planetary gear drive for best possible efficiency. A 2.7 HP permanent magnet electric motor powers the winch. Load is controlled by a load apportioned mechanical brake located in the winch drum. Ratio between winch drum and wire rope meets ANSI B30.5 requirements.

First layer performance of the winch is as follows:

Load-Lbs	Hook Speed-Ft/ Min.	Electrical-Amps @ 12VDC
1000	13.1	64
2000	11.9	115

WIRE ROPE and SHEAVES:
The crane is supplied with 62 Ft. of ¼ in. galvanized aircraft cable. Minimum breaking strength of the rope is 7000 lbs. The wire rope is outside of the boom and visible for operators continual inspection. All sheaves meet ANSI requirements.

HYDRAULIC SYSTEM:
A 12 volt D.C. electric hydraulic pump powers the crane's elevation on the 208EL.

ROTATION SYSTEM:
Rotation is 360 degrees continuous and unlimited. The Crane rotates on two 3.75" ID tapered roller bearings for smooth, long lasting operation. A band brake to help control swing is standard.

REMOTE PENDANT CONTROL:
An 18-Ft. long remote pendant is provided for control of each powered function. The Pendant control is removable from the crane to prevent unauthorized use of the crane.

LOAD SENSOR
A load-limiting sensor is supplied as standard. This sensor will shut down hoist up & boom down when an overload is detected. The sensor will reset after the load is lowered. Boom Up is limited by the Pressure relief setting in the pump.

POWER SOURCE:
Crane is powered by the truck's 12 volt DC system. A second battery is recommended to keep the voltage as high as possible and should be installed in parallel with the vehicle's battery. A Group 31"DEEP CYCLE" battery is recommended. 25 Ft of 1/0 battery cable with quick disconnect is included along with a 3-ft. battery ground wire (for grounding factory battery to truck frame), 150 amp circuit breaker and master cut off switch.

MOUNTING: A minimum 9,000 Lb. GVWR recommended.
An 8,600-Lb or larger GVWR chassis is recommended. Four 0.5" X 2.5" long Grade 8 hex head cap screws and lock nuts are provided. Mounting plate is 15" square with a 12" square bolt pattern.

OPTIONAL: Anti-Two Block for 208EL-14

OUTRIGGERS or JACKSTAND
An optional Jackstand or Outrigger is needed for stability and to reduce the load on the crane's rotation mechanism and the truck's suspension.



HOUSTON, TEXAS
FAX: (800) 824-5559 (USA & Canada)
FAX: (713) 688-6324
PHONE: (713) 688-5533
www.liftmoore.com

Bulletin 469-A 12/30/13