



SCX300

HYDRAULIC CRAWLER CRANE

Specifications

HITACHI SUMITOMO

SCX300

HYDRAULIC CRAWLER CRANE



CRAWLER CRANE	■Dimensions ■Specifications	3
	■Technical Description	4
	■Working Ranges	8
	■Rated Loads for Main Boom	9
	■Crane Boom Construction	
	■Component Weights and Dimensions for Transport	10
CLAMSHELL	■Dimensions ■Specifications	
	■Working Ranges ■Clamshell Bucket	12
DRAGLINE	■Dimensions ■Specifications	
	■Working Ranges ■Dragline Bucket	13
TECHNICAL DATA	■Standard Equipment ■Front Attachments	14
	■Standard and Optional Equipment	15

Note: • All "ton" described in this catalog represent metric tons.
• Specifications conform to the Safety Regulations for Cranes and Mobile Cranes in Japan.

■Dimensions

Unit: mm

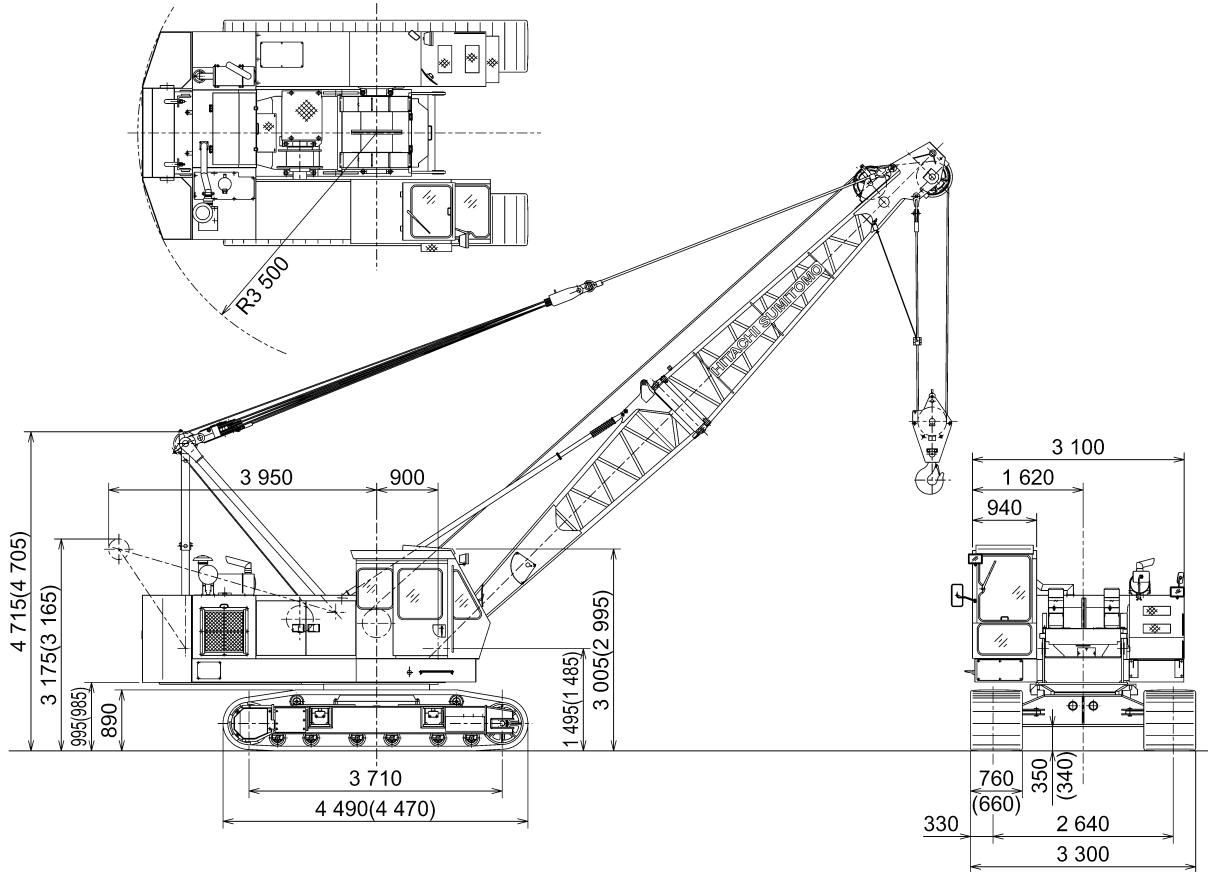

Notes: Dimensions shown in () are with optional 660 mm width shoe.

■Specifications

Maximum Lifting load × Load radius	ton × m	30 × 3.0		
Basic boom length	m	10		
Maximum boom length	m	34		
Wire rope speed	Main/Aux. hoisting	m/min	*70/35	Wire Rope Diameter 22 m
	Main/Aux. lowering	m/min	*70/35	
	Boom hoisting	m/min	*60	Wire Rope Diameter 14 m
	Boom lowering	m/min	60	
Swing speed	min ⁻¹ (rpm)	4.0 (4.0)		
Travel speed	km/h	*1.8		
Gradeability	deg. (%) °	21.8 (40)		
Ground pressure	kPa (kgf/cm ²)	53.9 (0.55)		
Engine model		Hino H06C-T		
Engine rated power	kw/min ⁻¹	110/2 000		
Operating weight (with 760 mm shoe)	ton	33.1 (with 10 m Boom + 30 t Hook)		

Notes : 1. Data is expressed in SI units, followed by conventional units in ().

2. *Line speeds will vary with the load.



Superstructure



Engine

Model	Hino H06C-T
Type	Water-cooled, 4-cycle, 6-cylinder, direct fuel injection type diesel engine
Rated power	110 kW (150 PS) at 2 000 min ⁻¹ (2 000 rpm)
Maximum torque	530 N·m (54 kgf·m) at 1 800 min ⁻¹ (1 800 rpm)
Piston displacement	6.845 L
Fuel tank capacity	250 L
Electric system	DC 24 V



Main and Auxiliary Hoist Mechanism

- The SCX300 is equipped with main and auxiliary drums installed on an axis.
- Hoisting and lowering the load is activated by forward/reverse rotation of the hydraulic motor.
- Power lowering is carried out with a hydraulic brake.
- Hoisting and lowering can be carried out at two speeds fast and slow to suit job requirements.
- Each drum is fitted with a friction band-type brake. This allows free fall (rapid lowering) of the bucket.
- Main and auxiliary hoist drums are each fitted with a pawl-type drum lock to positively hold the load in the air.
- The drum brake is an external contracting friction band-type using durable non-asbestos lining.
- The clutch is an internal expanding friction band-type using durable non-asbestos lining.



Boom Hoist Mechanism

- Boom hoisting/lowering is done by forward/reverse rotation of a hydraulic motor. Boom lowering is made by power lowering through a hydraulic brake.
- Both hydraulic brake and spring-set/hydraulic-released multi-plate disc type brake offer positive stopping of the boom. When the boom is hoisted or lowered, brakes are automatically released.
- Boom hoist drum is fitted with a pawl-type drum lock.



Swing Mechanism

- Independent operation separated from other functions.
- Driven by a hydraulic motor through reduction gear. Swing speeds are freely controllable from zero to maximum speed with a single lever.

Swing Brake

The disc-type swing brake can be hydraulically applied by the brake switch on the swing lever.

Swing Lock

Manual mechanical-lock with a rod tip engaged in the holder of the track frame for transportation.

Swing Circle

Single-row shear-type ball bearing with heat-treated internal gear.



Revolving Frame

All welded steel construction, stress-relieved, precision-machined for rigidity and strength.

Gantry

Lowerable for transportation.

Counterweight

Total weight: 8 800 kg



Boom

Angle Chord Crane Boom

935 mm wide by 935 mm deep at connection, lattice construction using high-tensile steel angle chords.

Basic boomTotal length 10.0 m, 2-piece construction; upper section 5.0 m and lower section 5.0 m.

Boom pointOffset boom point, 3 sheaves (462 mm PCD) mounted on anti-friction bearings on boom top.

Boom inserts3.0 m and 6.0 m long available.

Connection typePin-connected.

Boom backstopDual-rail, telescopic tubular construction with spring damper.

Boom hoist bridleServes as connection between pendants and boom hoist wire rope reeving, equipped with 6 sheaves (300 mm PCD) for 12-part boom hoist wire rope reeving.



Operator's Cab

All-weather, well-ventilated, roomy operator's cab with good visibility. The independent cab is insulated against noise and vibration. Sliding, fold-in front window swings up and stores in roof.



HYDRAULIC SYSTEM

- 2 variable displacement piston pumps allow both independent and combined operations of all functions.
- Variable displacement piston pumps control working speeds, and make effective use of engine horsepower.

	Pump-1	Pump-2
Type of pump	Variable displacement	
Pressure setting	27.4 MPa (280 kgf/cm ²)	27.4 MPa (280 kgf/cm ²)
Max. oil flow*	200 L/min	200 L/min

	Pump-3	Pump-4
Type of pump	Gear	Gear
Pressure setting	20.6 MPa (210 kgf/cm ²)	4.4 MPa (45 kgf/cm ²)
Max. oil flow*	134 L/min	32 L/min

*with non-loaded condition

Main and Auxiliary Hoist Motors (Common Motor)

Axial piston motors with counterbalance valves.

Boom Hoist Motor

Axial piston motor with counterbalance valve.

Swing Motor

Axial piston motor.

Travel Motors

Axial piston motors with brake valve and spring-set/hydraulic-released multiplate disc brake

Relief and Brake Valves

- Each hydraulic circuit incorporates large-capacity relief valves to protect circuit from overload and shock load.
- Counterbalance valves, provided for hoist motor, compensate load lowering and prevent accidental load drop if hydraulic power is suddenly reduced.
- Brake valves (consisting of relief valve and counterbalance valve) are provided for travel circuit.

Pressure Settings

Main Circuit

- Main relief valves

Hoist (main and aux.) 27.4 MPa (280 kgf/cm²)
 Swing 20.6 MPa (210 kgf/cm²)

- Overload relief valves

Hoist (main and aux.) circuits 28.1 MPa (287 kgf/cm²)
 Boom hoist circuit 25.9 MPa (265 kgf/cm²)
 Travel circuit 31.8 MPa (325 kgf/cm²)

Pilot Circuit

- Main relief valve

..... 4.4 MPa (45 kgf/cm²)

Line Filters

High-filtration 10 μm full-flow filter element is incorporated in the return line. Pilot filter and suction filter are provided in each circuit.



Undercarriage

Traction mechanism

- Each track is driven by an axial piston motor through reduction gear. This mechanism allows counter-rotation of tracks for maneuverability in close quarters.
- When the lever is in neutral position, both hydraulic brake and spring-set/hydraulic-released multiplate disc brake are automatically applied for stopping.

Track Frame

All-welded, stress-relieved, box-section construction

Side Frames

Side frames of all-welded robust rolled steel, stress relieved, box section construction.

Track Shoes

Heat-treated alloy steel castings with induction-hardened roller path and driving lugs.

No. of upper rollers (each side).....	2
No. of lower rollers (each side).....	6
No. of track shoes (each side)	53
Shoe width.....	760 mm
Optional shoe width.....	660 mm



Controls

Boom, Main and Auxiliary Hoist, Swing and Travel

Remote controlled hydraulic servo. Working speed can be precisely controlled according to lever stroke.

● Monitor Telling Machine Conditions

With the monitor, the operator can check, at a glance, engine oil pressure, water temperature and fuel level, as well as levels of hydraulic oil, engine oil and coolant. The red light turns on and/or the buzzer sounds in the event of an abnormality.



Safety Device

Boom Angle Indicator

Mechanical-type boom angle indicator is provided at boom foot.

Counterbalance Valves (Brake Valves)

Counterbalance valves are each incorporated in travel motors, boom hoist motor, and main and auxiliary hoist motor. If the hydraulic line is broken, this valve is automatically actuated to prevent motor rotation.

Spring-Set/Hydraulic-Released Multiplate Disc Type Travel Brakes

Swing Lock and Swing Parking Brake

Drum Locks

A pawl-type drum lock is adopted for main drum, auxiliary drum and boom drum.

Lever Locks

Main and auxiliary clutch levers are each fitted with lock mechanisms to prevent mishandling.

Devices for Crane Operation

● Moment Limiter

The "Hi-Limiter" electrically detects the lifting load, and working radius from the boom angle. The detected data is calculated by a built-in microcomputer. When the lifting load reaches its alarm limit the "Hi-Limiter" buzzers, and when reaching the load limit, the control becomes inoperative.

● Hook Overhoist Prevention Device

When the hook reaches its hoist limit, the bell sounds and the auto-stop automatically actuates at the same time.

● Boom Overhoist Prevention Device

When the boom reaches its angle limit, the buzzer alarm sounds and boom hoisting automatically stops at the same time. The telescopic-type boom backstop is also provided.

● Secondary Boom Overhoist Prevention Device

In addition to the hook overhoist prevention device and boom overhoist prevention device, the secondary boom overhoist prevention device is provided.

● Reliable mechanism

The related movements stop automatically if an electric wire is broken.



Service Refill Capacities

	Liter
Fuel tank	250
Engine coolant	26.0
Engine oil	20.0
Pump transmission	2.7
Boom hoist reduction device	5.6
Winch hoist reduction device	11.5
Swing reduction device	8.7
Travel final device	8.5×2
Hydraulic system, including tank capacity	285
Hydraulic tank	200

■ Working Ranges

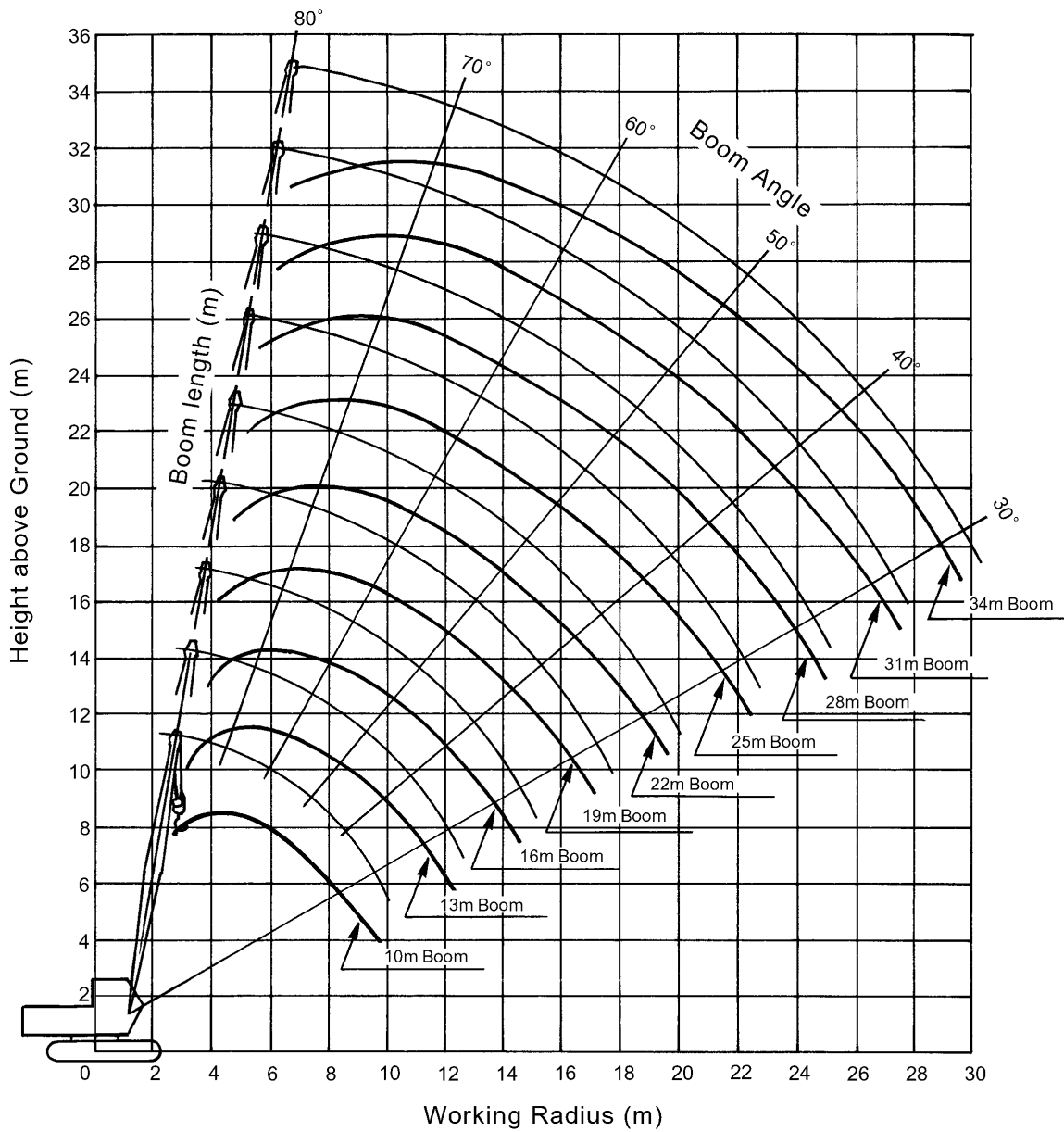

■ Correlation between the number of rope falls, maximum rated loads, hook weight are shown in the table below.

Hook capacity (ton)	Hook weight (ton)	Maximum rated loads (t)				
		5 Rope reevings	4 Rope reevings	3 Rope reevings	2 Rope reevings	1 Rope reeving
30.0	0.36	30.0	26.0	19.5	13.0	—
15.0	0.32	—	—	15.0	13.0	—
5.0	0.13	—	—	—	—	5.0

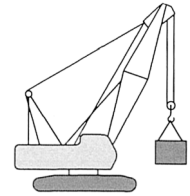

Unit: t

Rated Loads for Main Boom

Working radius (m)	Boom length (m)								
	10	13	16	19	22	25	28	31	34
3.0	30.00								
3.5	23.85	3.6×22.70							
4.0	19.40	19.35	4.1×18.45						
4.5	16.30	16.25	16.20	4.6×15.45					
5.0	14.05	13.95	13.90	13.85	5.1×13.40				
6.0	10.95	10.85	10.75	10.70	10.60	10.55	6.5×9.45		
7.0	8.90	8.80	8.70	8.65	8.55	8.50	8.40	8.30	
8.0	7.45	7.35	7.25	7.20	7.10	7.05	6.95	6.85	6.75
9.0	6.40	6.30	6.20	6.15	6.00	6.00	5.85	5.75	5.65
10.0	9.6×5.90	5.45	5.35	5.30	5.20	5.15	5.00	4.95	4.80
12.0		4.30	4.20	4.10	4.00	3.95	3.80	3.75	3.60
14.0		12.2×4.25	3.35	3.30	3.15	3.10	3.00	2.90	2.80
16.0			14.8×2.90	2.70	2.55	2.50	2.40	2.30	2.20
18.0				17.4×2.45	2.10	2.05	1.95	1.85	1.75
20.0					1.80	1.70	1.60	1.50	1.35
22.0						1.40	1.30	1.20	1.10
24.0						22.6×1.35	1.05	0.96	0.85
26.0							25.2×0.90	0.80	0.65

- Notes:
1. The rated loads shown do not exceed 78% of tipping load with the machine on firm level ground, and are not less than 1.15 times over-front stability stipulated by the mobile crane construction standards.
 2. To calculate the maximum load that can actually be lifted, deduct weight of all lifting accessories, such as main and aux. hooks, from figures shown above.
 3. Working radius is the horizontal distance from the swing center to the center of gravity of a lifted load.
 4. The counterweight is 8.8 ton.
 5. Figures described as ○○×○○ in the tables indicate working radius (m) × rated load (ton).

■Crane Boom Construction

Elements		Boom length (m)								
		10	13	16	19	22	25	28	31	34
Lower boom	5.0 m	1	1	1	1	1	1	1	1	1
Upper boom	5.0 m	1	1	1	1	1	1	1	1	1
3 m boom insert		—	1	2	1	2	1	2	1	2
6 m boom insert		—	—	—	1	1	2	2	3	3
Available aux. jib		←—————→								

Boom inserts combination:

6 m boom insert can be replaced with two 3 m boom inserts.

■Component Weights and Dimensions for Transport

Components		Weight (ton)	Length × Width × Height (m)			Remarks
Basic machine	Basic machine	23.30	9.90	3.30	3.18	Including lower boom, ropes
	Counterweight	8.80	0.72	3.04	1.28	
Crane front	Lower boom	0.84	5.14	1.30	1.18	
	Upper boom	0.80	5.39	1.07	1.16	
	Bridle	0.20	1.20	0.59	0.22	
	3 m boom insert	0.32	3.10	1.03	1.07	
	6 m boom insert	0.53	6.10	1.03	1.07	
	30 t hook	0.36	1.51	0.62	0.30	
	15 t hook	0.32	1.36	0.62	0.29	
5 t hook	0.13	0.77	0.30	0.30		

■Dimensions

Unit: mm

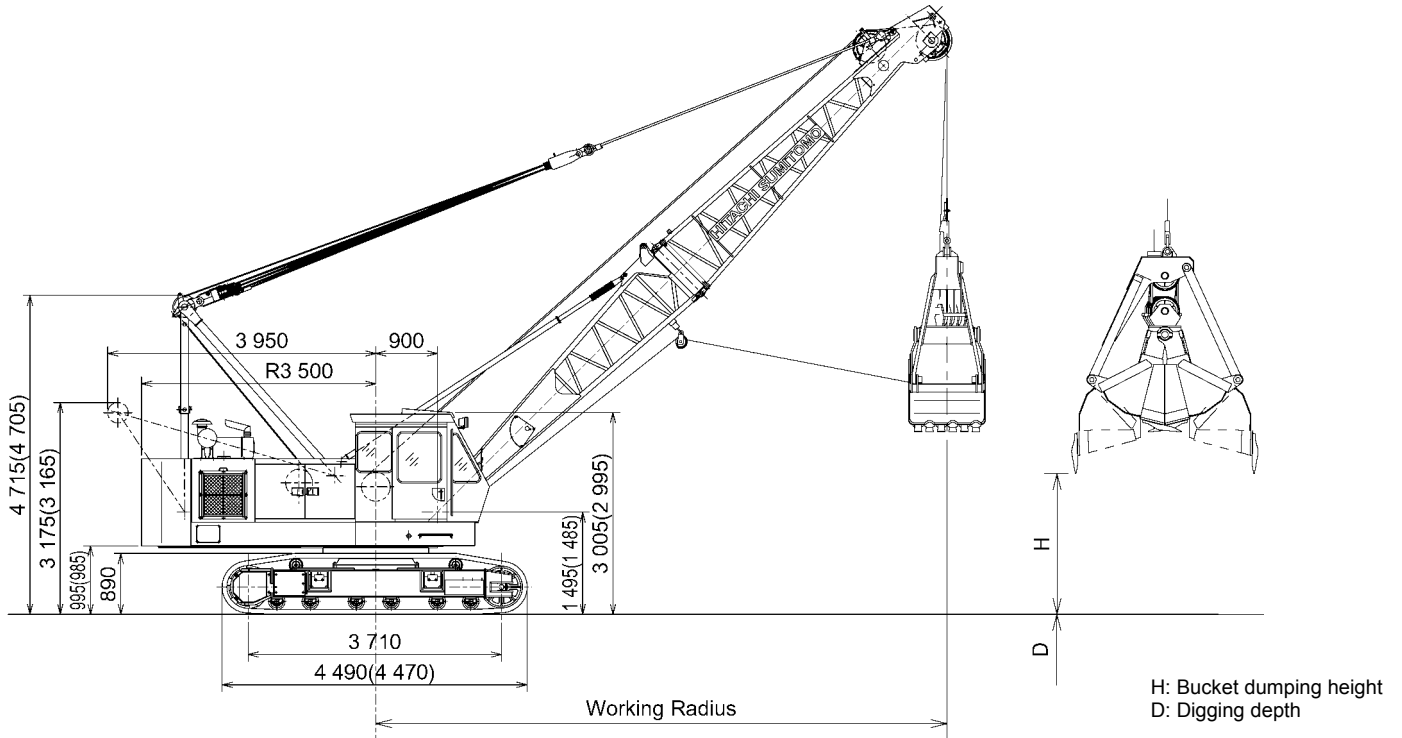

Notes: Dimensions shown in () are with optional 660 mm width shoe.

■Specifications

Bucket capacity	m ³	0.8/1.0/1.2
Allowable clamshell gross weight	ton	5.5
Max. bare line pull (1st drum layer)	ton	14.6
Boom length	m	10 to 19
Max. digging depth	m	36
Suspend line speeds	m/min	*70/35 Rope 22 mm dia.
Open/close line speeds	m/min	*70/35 Rope 22 mm dia.
Boom hoist/ lower line speed	m/min	*60 Rope 14 mm dia.
Travel speeds	km/h	1.8
Ground pressure	kPa (kgf/cm ²)	56.9 (0.58)
Operating weight (with 760 mm shoe)	ton	35.0 (10 m boom + 1.0 m ³ bucket)
Engine	kW/min ⁻¹ (PS/rpm)	H06C-T/Hino 110/2 000 (150/2 000)

■Clamshell Bucket

Capacity (m ³)	Weight (ton)	Use
0.8	2.00	Excavation
1.0	2.45	Excavation
1.2	2.40	Excavation (Light service)

Notes: 1. Data is expressed in SI units, followed by conventional units in ().

2. Other specifications, not shown, are similar to those for the crawler crane.

*Line speeds will vary with the load.

■Working Ranges

Boom length	m	10				13				16				19			
Boom angle	degree	35	45	55	65	35	45	55	65	35	45	55	65	35	45	55	65
Working radius	m	9.4	8.3	7.0	5.5	11.8	10.4	8.7	6.7	14.3	12.6	10.4	8.0	16.8	14.7	12.2	9.3
Rated load	ton	5.50	5.50	5.50	5.50	5.50	5.50	5.50	5.50	2.80	5.50	5.50	5.50	2.30	5.23	5.50	5.50
Bucket dumping height 0.8 m ³ bucket	m	2.0	3.3	4.5	5.4	3.7	5.5	7.0	8.1	5.4	7.6	9.4	10.8	7.1	9.7	11.9	13.6
1.0 m ³ bucket	m	1.8	3.1	4.3	5.2	3.5	5.3	6.8	7.9	5.2	7.4	9.2	10.6	6.6	9.5	11.7	13.4
1.2 m ³ bucket	m	1.6	2.9	4.1	5.0	3.3	5.1	6.6	7.7	5.0	7.2	9.0	10.4	6.7	9.3	11.5	13.2

Notes: 1. Rated loads for clamshell do not exceed 90% those for crane.

2. The rated loads shown are upper limits determined by the following equation. Please select a bucket in such a manner that its rated load does not exceed the rated load shown above, according to kinds of the loads handled.

$$\text{Rated load} = \text{Bucket capacity (m}^3\text{)} \times \text{Specific gravity of load (ton/m}^3\text{)} + \text{Bucket weight (ton)}$$

Be careful that brake will be overheated if the bucket is too heavy even within the rated loads.

3. Working radius is the horizontal distance from the swing center to the center of gravity of lifted load.

4. The bucket weight is 2.45 ton max.

5. The counterweight is 8.8 ton.

6. Free fall using brake will vary with operating conditions such as bucket weight and work cycle, but its height should be within 10 m.

■Dimensions

Unit: mm

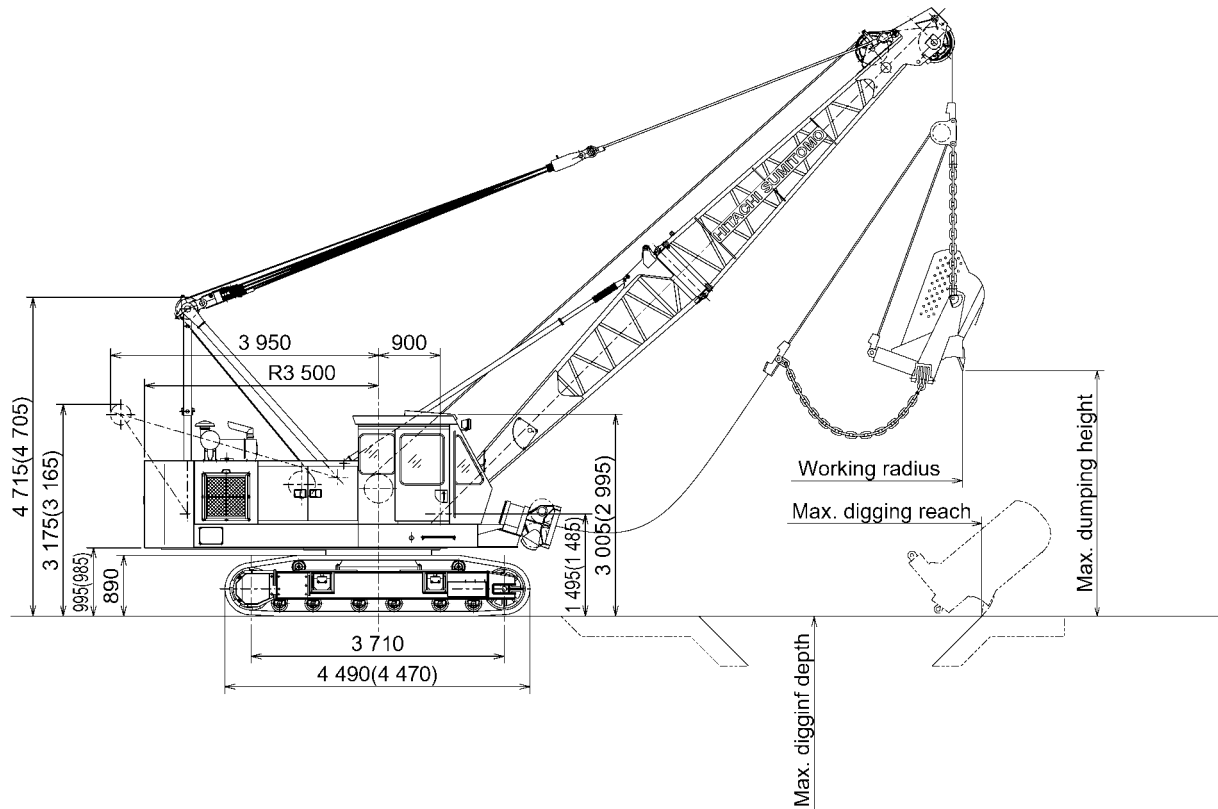

Notes: Dimensions shown in () are with optional 660 mm width shoe.

■Specifications

Bucket capacity	m ³	0.8, 1.0	
Boom length	m	10 to 19	
Suspend line speeds	m/min	*70/35	Rope 22 mm dia.
Drag line speeds	m/min	*70/35	Rope 22 mm dia.
Boom hoist/lower line speed	m/min	*60	Rope 14 mm dia.
Travel speeds	km/h	1.8	
Swing seeds	min ⁻¹ (rpm)	4.0 (4.0)	
Ground pressure	kPa (kgf/cm ²)	56.9 (0.58)	
Operating weight (with 760 mm shoe)	ton	44.9 (10 m boom + 1.0 m ³ bucket)	
Engine	kW/min ⁻¹ (PS/rpm)	H06C-T/Hino 110/2 000 (150/2 000)	

■Dragline Bucket (Reference data)

Capacity (m ³)	Weight (ton)	Use
0.8	1.20	Excavation
1.0	1.60	Excavation

Notes: 1. Data is expressed in SI units, followed by conventional units in ().
 2. Other specifications, not shown, are similar to those for the crane.
 3. *Line speeds will vary with the load.

■Working Ranges

Boom length	m	10			13			16			19		
Boom angle	degree	30	40	50	30	40	50	30	40	50	30	40	50
Working radius	m	9.9	8.9	7.7	12.5	11.3	9.6	15.1	13.5	11.6	17.7	15.8	13.5
Rated load	ton	5.4	5.4	5.4	5.4	5.4	5.4	4.1	4.7	5.4	3.2	3.7	4.6
Max. digging reach	m	12.8	12.5	11.8	16.1	15.7	14.7	19.3	18.8	17.8	22.6	21.2	20.7
Max. digging depth	m	6.6	6.4	5.9	9.1	8.8	8.1	11.5	11.2	10.4	14.0	13.0	12.6
Boom dumping height (0.8 m ³ bucket)	m	2.6	4.1	5.3	4.1	6.0	7.6	5.6	7.9	9.9	7.1	9.9	12.2

Notes: 1. The size of the bucket has to be determined according to local conditions.
 2. The rated loads shown are upper limits determined by the following equation. Please select a bucket in such a manner that its rated load does not exceed the rated load shown above, according to kinds of the loads handled.
 Rated load = Bucket capacity (m³) × Specific gravity of load (ton/m³) + Bucket weight (ton)
 Be careful that brake will be overheated if the bucket is too heavy even within the rated loads.
 3. Working radius is the horizontal distance from the swing center to the center of gravity of lifted load.
 4. Maximum digging reach/depth may vary considerable depending on digging condition and the skill of the operator.
 5. The counterweight is 8.8 ton.

■ STANDARD EQUIPMENT

BASIC MACHINE

Undercarriage

- Crawler-type undercarriage (with 760 mm shoes)

Superstructure

- Front lights (2 pcs)
- Rearview mirrors (left and right)
- Centralized lubrication system (for gantry and swing circle)
- Electric refuel device
- Under-cover (at cab and superstructure bottom)
- Cab entrance steps
- 8.8 ton counterweight
- Standard tool kit

Cab

- Sunvisor
- Floor mat
- Room light
- Cigarette lighter
- Ashtray
- AM radio

Safety Devices

- Swing lock
- Drum pawl lock (main and auxiliary hoist, and boom hoist)
- Swing alarm
- Before-work check monitor

FRONT ATTACHMENTS

Crane

- 10 m basic boom (lower 5.0 m, upper 5.0 m)
- Boom back stop
- Boom angle indicator
- 30 ton hook
- Main hoist rope ($\phi 22$ mm \times 130 m)
- Boom hoist rope ($\phi 14$ mm \times 130 m)
- Moment limiter
- Overhoist prevention devices (main hook, boom hoist, secondary)

Clamshell

- 10 m basic boom (lower 5.0 m, upper 5.0 m)
 - Boom back stop
 - Boom angle indicator
 - Open/close and suspend rope disengagement prevention device
 - Open/close rope ($\phi 22$ mm \times 67 m)*
 - Suspend rope ($\phi 22$ mm \times 60 m)*
 - Hydraulic tagline with $\phi 10$ mm \times 45 m rope
 - Boom hoist rope ($\phi 14$ mm \times 130 m)
- * Open/close and suspend ropes are determined based on 19 m boom length and 12 m digging depth.

Dragline

- 10 m basic boom [Lower 5.0 m, upper 5.0 m and wide-angle sheaves (with 1 boom-point sheave)]
- Boom back stop
- Boom angle indicator
- Hoist rope ($\phi 22$ mm \times 50 m)
- Drag rope ($\phi 22$ mm \times 34 m)
- Boom hoist rope ($\phi 14$ mm \times 130 m)
- Fair-lead
- Overhoist prevention device (for boom hoist and secondary hoist)

Standard and Optional Equipment

○: Standard ●: Option —: Not recommended

	CRAWLWER CRANE	CLAMSHELL	DRAGLINE
Undercarriage			
660 mm width shoe	●	●	●
Superstructure			
Drum cooler (for aux. drum)	—	●	—
Side walk (folded type)	●	●	●
Side walk (fixed type with handrails)	●	●	●
Fuel double element	●	●	●
Engine air cleaner double element	●	●	●
Under-cover (Extra)	●	●	●
Cab			
AM/FM radio	●	●	●
Fan	●	●	●
Loudspeaker	●	●	●
Heater	●	●	●
Air conditioner	●	●	●
Safety devices			
Foam type level (in cab)	●	●	●
Bucket overhoist prevention device	—	●	—
Front attachments for crane and tower crane			
30 ton hook (5-rope reevings)	○	—	—
15 ton hook (3-rope reevings)	●	—	—
5 ton hook	●	—	—
3 m boom insert	●	●	—
6 m boom insert	●	●	—
Aux. Jib assembly [aux. Jib, aux. Jib hook overhoist prevention device, aux. Jib rope (φ22 mm × 120 m), 5.0 ton hook]	●	—	—
Aux. Jib (aux. jib, aux. jib hook over hoist prevention device)	●	—	—
Front attachment for other			
0.8 m ³ clamshell bucket	—	●	—
1.0 m ³ clamshell bucket	—	●	—
1.2 m ³ clamshell bucket (light-service)	—	●	—
Hydraulic tagline	●	○	—
Open/close and suspend rope	—	○	—
0.8 m ³ Dragline bucket	—	—	●
1.0 m ³ Dragline bucket	—	—	●
Fair-lead	—	—	○

*This catalog is not applicable to European and North America areas.
The machine shown may vary according to territory Specifications.*

Hitachi Sumitomo Heavy Industries Construction Cranes Co.,Ltd

Head Office : 12-14 Ueno 7-chome, Taito-ku,
Tokyo 110-005, Japan

Telephone : (03)3845-1386

Facsimile : (03)3845-1394

<http://www.hands-crane.com>

KC-E156

Printed in Japan. 02.10 (KA/KA, FT₃)