

**30,000 lbs (13,600 kg)
at 10 ft (3.05m) Radius**

- Rated Capacity Limiter ... Standard
- Capacity on Outriggers ... 30,000 lbs (13,600 kg)
- Pick and Carry Capacity ... 18,300 lbs (8,300 kg)
- Height ... 11' 2" (3.4 m)
- Width ... 8' 2" (2.49 m)
- Boom Rotation ... 360 Degree Continuous
- Sheave Height ... up to 87' 11" (26.8 m)
- Horizontal Reach ... up to 80' (24.38 m)
- 4-Wheel Steer ... Standard
- 4-Wheel Drive ... Standard
- Powershift Transmission ... Standard
- Fully Hydraulic Controls for Smooth Precise Operations
- Independent Outrigger Controls
- Diesel Engine ... Standard

BRODERSON
Manufacturing Corp.

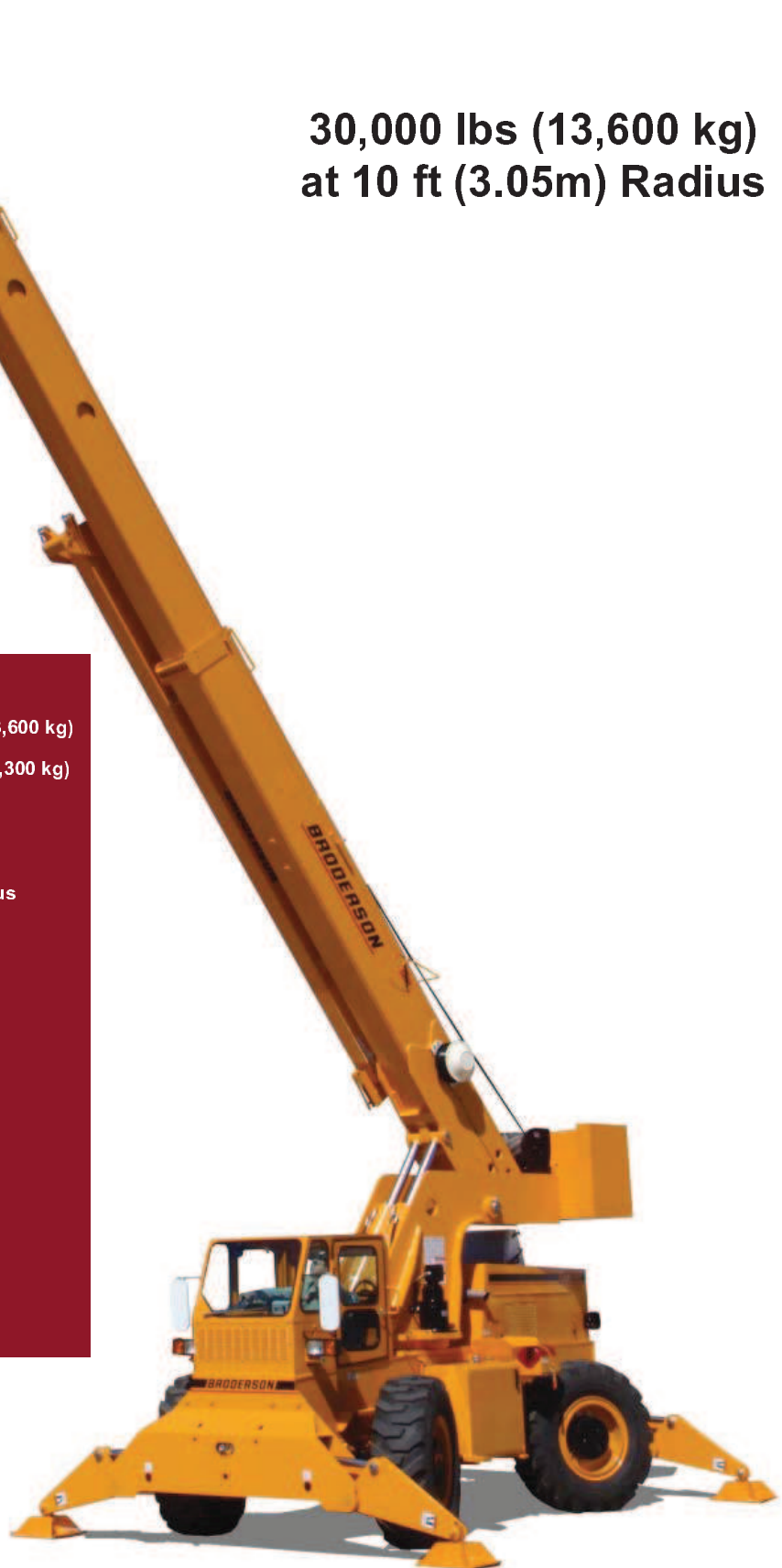

RT-300-2F

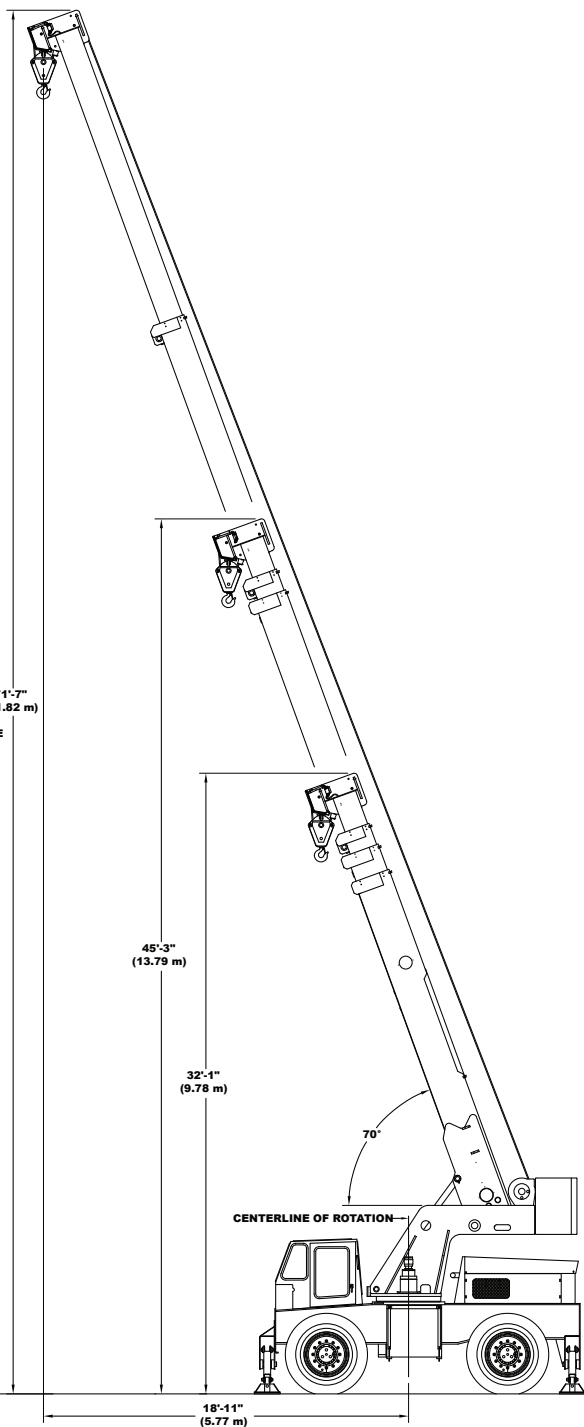
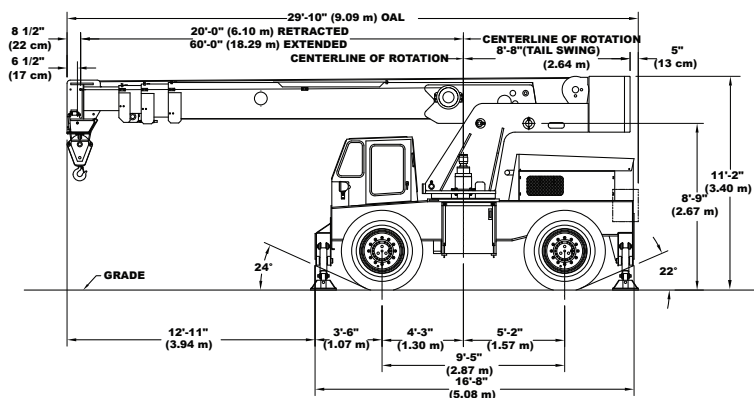
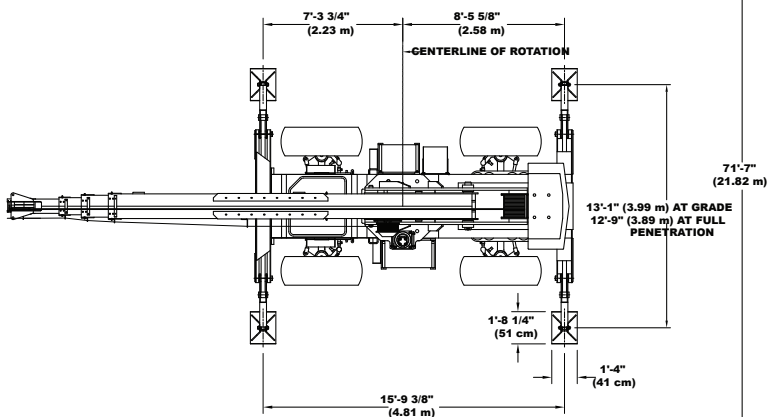
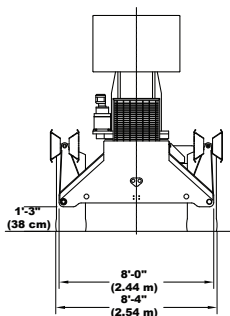
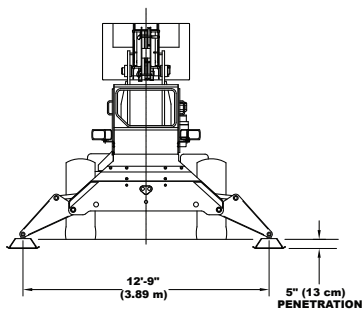

RT-300-2F

Specifications

GENERAL:

Weight:	
Total	45,330 lbs (20,560 kg)
Front Axle	22,930 lbs (10,400 kg)
Rear Axle	22,400 lbs (10,160 kg)
Angle of Approach	24 Degrees
Angle of Departure	22 Degrees
Gradeability	70 Percent Grade (35 degrees)
Turning Radius: 4-Wheel Steer: (Min.)	
Outside Tire C/L Radius	15 Feet 7 Inches (4.75 m)
Vehicle Clearance Circle (Dia.)	35 Feet 2 Inches (20.73 m)
Drawbar Pull	30,000 pounds (13,600 kg)
Road Speed	23 Miles Per Hour (37 km/h)

ENGINE:

Make	Cummins
Model	QSB 4.5 Turbo, U.S. EPA Tier 3 Certified
Type	Turbo Diesel, Charge Air Cooled
C.I.D.	4.5L
Max. Torque	460 ft lbs (624 Nm) @ 1500 rpm
Rated HP	160 hp (119 kw) @ 2500 rpm
Fuel Tank	50-Gallon (190L) Capacity

TRANSMISSION

6-Speed Powershift with Torque Converter, Oil Cooler and Oil Filter

AXLES:

Front and Rear Axles:	
Gear Ratio	16.42:1

BRAKES:

- Service** - 4-Wheel drum type with hydraulic booster
- Parking** - Spring-applied and hydraulically-released mounted on transmission

STEERING:

Hydraulic steering unit with two 3.5 inch (8.9 cm) cylinders attached to each axle. Allows limited steering when engine is not running. A switch on the control panel is used to select front-wheel steering, 4-wheel steering or crab steering. Electronic sensors and control box automatically align the steering when a new mode is selected.

TIRES:

Standard - 17.5 x 25, 20-Ply Rating Mud Lug.

CHASSIS:

Outriggers:
Four independently controlled swingdown design outriggers. The hydraulic cylinders are equipped with direct-connected holding valves.

OPERATOR COMPARTMENT:

Operator control station provides one-position access to all chassis and crane controls.

All Weather Cab

Consists of rigid-mounted canopy section and two removable hinged doors. Includes heater with 2-speed fan, 12-volt electric windshield wiper. Defroster fan included.

ELECTRICAL SYSTEM:

12-Volt DC System

Instrument Group:

Fuel, transmission oil temperature, voltmeter, engine oil pressure, water & hydraulic oil temperature gauges, & hourmeter.

Lighting Kit

Includes dual-beam headlights with turn signal lights. Taillights with brake & turn signal lights. Back-up lights.

Back-Up Alarm:

Provides pulsating sound from 97 dB alarm when ignition is on & transmission is in reverse.

Outrigger Alarm System:

112 dB alarm with alternating two-tone alarm is activated when "outrigger down" controls are operated.

HYDRAULIC SYSTEM:

Triple vane pump, mounted & driven by main transmission. Rated 9, 26 & 44 gpm (53, 106 & 151L/min) at 3,000 psi (207 bar) at 2,500 RPM engine speed. Hydraulic oil tank capacity of 70 gallons (265 L).

BOOM ASSEMBLY:

	Boom Movement	Boom Speeds
Rotation	Continuous	3.3 RPM
Elevation	0 - 70 Degrees	19 Seconds
Extension	40 ft (12.19 m)	24 Seconds

Boom Assembly:

Boom assembly equipped with bearing pads. Double-acting hydraulic cylinders, equipped with a holding valve, extend & retract the second and third boom sections. Double runs of high strength leaf chain extend & retract the fourth section. Boom angle indicator included on left side of boom. Twin, double-acting hydraulic cylinders control the boom elevation & are equipped with direct-connected holding valves.

Boom Rotation:

A heavy-duty ball bearing rotation gear with external teeth. Rotation is powered by the hydraulic motor and compound planetary gear drive. Spring-applied, hydraulically released brake and an overrunning load valve are provided. Hydraulic centerpost and electric slip rings allow continuous rotation.

Boom Hoist:

Turret Mounted

Hydraulic Powered

Bare Drum Line Pull	13,100 lbs (5,940 kg)
Wire Rope	350 ft (107 m) of 9/16 in (14.3 mm) dia.

Line Speed:

Bare Drum	185 fpm (56 m/min)
Full Drum	240 fpm (72 m/min)

4-Part-Line Sheave Block:

Double sheave block for four-part-line requirement. Downhaul weight and hook also included.

Anti-Two-Block Device:

Prevents damage to hoist rope and/or machine components from accidentally pulling load hook against boom tip.

Rated Capacity Limiter:

Warns operator of impending overload with audible & visual signals. In the event of overload, stops boom functions that increase overloads. Displays boom length, angle, load radius, load & capacity.

RT-300-2F

Options

Listed below are brief descriptions of options available for this product.
Consult the RT-300-2F Engineering Spec for additional information.

TIRE OPTIONS:

Spare Wheel & Tire:
17.5 x 25, 20-Ply Tire

CHASSIS OPTIONS:

Fenders

Four bolt on steel fenders over tires.

Auxiliary Front Winch

Planetary gear winch mounted on front outrigger frame, with single-lever control on the operator console. Operator Guard required.

Lifting Eyes

Lifting eyes on corners of the chassis and the turntable so slings can be attached for lifting crane.

Towing Eyes

Consists of four eyes, two on the front and two on rear for towing.

Pintle Hook, Front

Pintle hook mounted on the front outrigger housing, 24-ton capacity.

Pintle Hook, Rear

Pintle hook mounted on the rear outrigger housing, 24-ton capacity.

OPERATOR COMPARTMENT OPTIONS:

Window Wiper - Top Window

12-volt electric wiper on top window operated with its own switch.

Operator Guard

Tubular steel weldment with heavy expanded steel mesh top & grille front section.

Operator Suspension Seat

Seats Inc. - Cloth

Full-suspension with adjustments for height, tilt, fore/aft, operator weight with armrest angle adjustment.

Operator Suspension Seat

Seats Inc. - Vinyl

Full-suspension with adjustments for height, tilt, fore/aft, operator weight with armrest angle adjustment.

Floor Mat

Vinyl mat with foam backing.

Air Conditioning

Air Conditioning with R134 coolant.

ELECTRICAL OPTIONS:

Strobe Light

Yellow strobe light mounted on top of engine hood for high visibility.

Boom Work Lights

One halogen work light mounted to boom to light boom tip and one work light mounted to turret to light ground under boom tip.

BOOM ATTACHMENT OPTIONS:

20-Ft. Offsettable Boom Extension

Boom stowable. Offsets include 0 (in-line), 15 or 30 degree.

Should you require an option or special equipment not listed please consult your dealer salesperson or BMC®.

BRODERSON
Manufacturing Corp.
14741 West 106th Street
Lenexa, KS 66215 USA

Tel (913) 888-0606
Fax (913) 888-8431
www.bmccranes.com

Dimensions and values shown are
for reference purposes only.
Specifications subject to change.



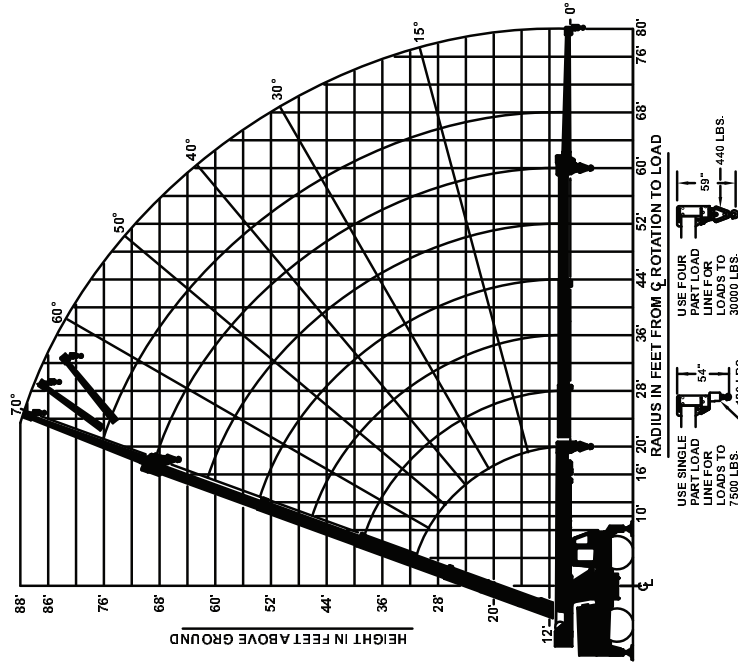

LOAD RADIUS FEET	CAPACITIES APPLY TO OPERATION ON FIRM LEVEL SURFACE					
	360° ROTATION			OVER FRONT		
	ON RUBBER	ON OUTRIGGERS	ON RUBBER	ON RUBBER	ON OUTRIGGERS	ON RUBBER
10	18300	30000	26300	30000	30000	28500
12	13500	28500	22500	25900	25900	22500
14	10400	25900	17600	22500	22500	19500
16	8300	22500	14000	19500	19500	17000
18	6700	19500	11400	16900	16900	15000
20	5500	16900	9400	14200	14200	13500
22	4500	14200	7900	12100	12100	11900
24	3700	12100	6600	10500	10500	10600
26	3100	10500	5700	9100	9100	9800
28	2500	9100	4800	7900	7900	8600
30	2000	7900	4200	6900	6900	8000
32	1600	6900	3600	6300	6300	7500
34	1400	6300	3200	5700	5700	6900
36	1200	5700	2900	5200	5200	6500
38	900	5200	2600	4800	4800	6000
40	800	4800	2400	4400	4400	5600
42	600	4400	1900	3900	3900	4900
44	500	3900	1600	3500	3500	4200
46	400	3500	1300	3100	3100	3700
48	300	3100	1000	2700	2700	3200
50	250	2700	800	2300	2300	2800
52	200	2300	600	1950	1950	2300
54	150	1950	400	1750	1750	2250
56	100	1750	300	1500	1500	1850
58	75	1500	200	1300	1300	1600
60	50	1300	1000	1000	1000	1100

DO NOT POSITION BOOM AT LOAD RADI WHERE NO LOAD CAPACITIES ARE SHOWN.

BOOM EXTENSION OFFSET ANGLE	20-FOOT BOOM EXTENSION CAPACITIES					
	0°	15°	30°	40°	50°	70°
0°	2300	2400	2700	3100	3700	4500
15°	---	2300	2400	2600	2900	3400
30°	---	---	2300	2400	2500	2700

CAUTION: BOOM EXTENSION LOADS MUST NOT EXCEED MAIN BOOM CAPACITY.

LOAD RADIUS IS THE HORIZONTAL DISTANCE FROM CENTER OF ROTATION TO THE VERTICAL LOAD LINE WITH LOAD APPLIED. LOAD HOOKS, DOWNHAUL WEIGHTS, HOOK BLOCKS AND OTHER LOAD HANDLING DEVICES SHALL BE CONSIDERED PART OF THE LOAD EXCEPT FOR HOIST ROPE.

BOOM EXTENSION DEDUCT: 500 LBS. WHEN STOWED ON BASE BOOM. CAPACITIES ON OUTRIGGERS ARE 85% OF TIPPING LOADS. CAPACITIES ON RUBBER ARE 75% OF TIPPING LOADS. CAPACITIES BELOW BOLD LINES ARE LIMITED BY TIPPING. OTHER CAPACITIES ARE LIMITED BY STRUCTURAL OR HYDRAULIC CAPACITY.

THE BOOMS ON THIS UNIT ARE ALL STEEL AND HAVE NO LINE VOLTAGE RATING - NO ELECTRICAL INSULATION VALUE.

MAXIMUM HYDRAULIC PRESSURE - 3000 PSI.

- OPERATION:
1. READ AND UNDERSTAND OWNERS MANUAL BEFORE OPERATING.
 2. CHECK LEVEL OF HYDRAULIC OIL AND ENGINE OIL DAILY.
 3. CHECK UNIT FOR VISIBLE DEFECTS AND LOOSE PARTS DAILY.
 4. OUTRIGGERS MUST ALL BE SET ON SOLID SURFACE.
 5. AVOID QUICK STARTS AND STOPS WITH HYDRAULIC CONTROLS.
- PICK AND CARRY ON RUBBER CAPACITIES ARE FOR SMOOTH, LEVEL PAVED SURFACE. FOR UNPAVED SURFACE REDUCE CAPACITY BY AT LEAST 25%.

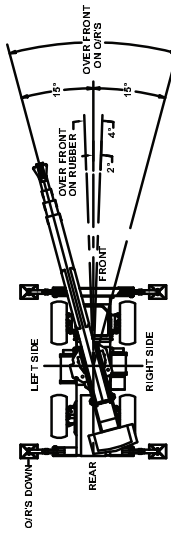

THE LOAD HOIST LINE ON THIS UNIT MUST BE 9/16" DIA. 6 X 36-EP-RR-L-HWRC WIRE ROPE (OR EQUIVALENT) WITH A MINIMUM BREAKING STRENGTH OF 33,600 LBS. TIRE PRESSURE 100 PSI FOR 17.5-25 20PR.

Metric

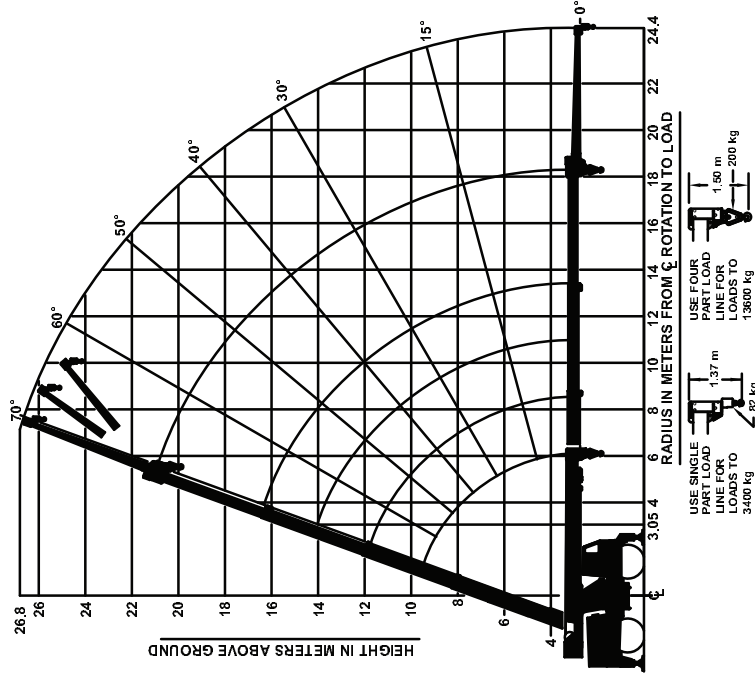

LOAD RADIUS METERS	CAPACITIES APPLY TO OPERATION ON FIRM LEVEL SURFACE			
	360° ROTATION ON RUBBER	ON OUTRIGGERS	ON RUBBER	ON OUTRIGGERS
3.05	8300	13600	10700	13600
3.5	6540	13160	8940	12290
4	5310	12290	7290	11160
4.5	4320	11160	6080	9920
5	3600	8820	5150	8820
5.5	3020	7870	4390	7870
6	2570	6930	3740	6930
7	1850	4680	2520	5320
8	1370	3700	1970	4460
9	960	3020	1540	3770
10	690	2570	1310	3390
11	540	2230	1120	3000
12	370	1960	930	2670
13	300	1860	860	2540
13.4	270	1720	780	2380
14	240	1530	680	2120
15	210	1380	570	1870
16	180	1230	460	1690
17	150	1080	380	1500
18	120	1040	360	1450
18.3	110	940	330	1310
19	90	840	300	1190
20	70	670	240	1040
22	50	500	180	910
24	450	450	170	770
24.4	450	450	170	720

DO NOT POSITION BOOM AT LOAD RADI WHERE NO LOAD CAPACITIES ARE SHOWN.

BOOM EXTENSION OFFSET ANGLE	6.1 m BOOM EXTENSION CAPACITIES					
	0°	15°	30°	40°	50°	60°
0°	1040	1090	1220	1400	1680	2170
15°	1040	1090	1180	1310	1540	1860
30°	1040	1090	1130	1220	1400	1700

CAUTION: BOOM EXTENSION LOADS MUST NOT EXCEED MAIN BOOM CAPACITY.

LOAD RADIUS IS THE HORIZONTAL DISTANCE FROM CENTER OF ROTATION TO THE VERTICAL LOAD LINE WITH LOAD APPLIED. LOAD HOOKS, DOWNHAUL WEIGHTS, HOOK BLOCKS AND OTHER LOAD HANDLING DEVICES SHALL BE CONSIDERED PART OF THE LOAD EXCEPT FOR HOIST ROPE.

BOOM EXTENSION DEDUCT: 225 kg WHEN STOWED ON BASE BOOM. CAPACITIES ON OUTRIGGERS ARE 85% OF TIPPING LOADS - ON RUBBER, 75% OF TIPPING CAPACITIES BELOW BOLD LINES ARE LIMITED BY TIPPING. OTHER CAPACITIES ARE LIMITED BY STRUCTURAL OR HYDRAULIC CAPACITY.

THE BOOMS ON THIS UNIT ARE ALL STEEL AND HAVE NO LINE VOLTAGE RATING - NO ELECTRICAL INSULATION VALUE. MAXIMUM HYDRAULIC PRESSURE - 207 bar

OPERATION:

1. READ AND UNDERSTAND OWNERS MANUAL BEFORE OPERATING.
2. CHECK LEVEL OF HYDRAULIC OIL AND ENGINE OIL DAILY.
3. CHECK UNIT FOR VISIBLE DEFECTS AND LOOSE PARTS DAILY.
4. OUTRIGGERS MUST ALL BE SET ON SOLID SURFACE.
5. AVOID QUICK STARTS AND STOPS WITH HYDRAULIC CONTROLS.

PICK AND CARRY ON RUBBER CAPACITIES ARE FOR SMOOTH, LEVEL PAVED SURFACE. FOR UNPAVED SURFACE REDUCE CAPACITY BY AT LEAST 25%.

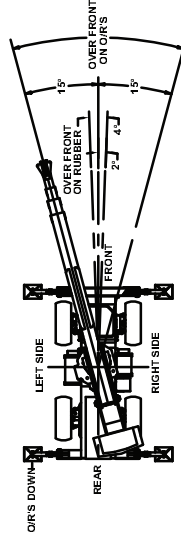

THE LOAD HOIST LINE ON THIS UNIT MUST BE 14.3 mm DIA. 6 X 36 EIP IWRC WIRE ROPE (OR EQUIVALENT) WITH A MINIMUM BREAKING STRENGTH OF 120 KN. TIRE PRESSURE 689 kPa FOR 17.5-25 20PR.

Metric