

# GROVE<sup>®</sup> RT75S

SELF-PROPELLED  
**HYDRAULIC CRANE with  
TRAPEZOIDAL<sup>†</sup> BOOM**

**50** TON CAPACITY  
**45** TONS METRIC

Meets requirements of F.C.R.A. Standards  
for hydraulic cranes



**HYDRAULIC  
CRANES**





<b>6,000 lbs.</b> (2 722kg)	@ <b>170'</b> TIP HEIGHT (51.8m)
<b>Jib offsets 5°, 17° or 30°</b>	
<b>9,600 lbs.</b> (4 355kg)	@ <b>147'</b> TIP HEIGHT (44.8m)
<b>17,500 lbs.</b> (7 938kg)	@ <b>121'</b> TIP HEIGHT (36.9m)
<b>20,000 lbs.</b> (9 072kg)	@ <b>115'</b> TIP HEIGHT (35.1m)
<b>31,000 lbs.</b> (14 062kg)	@ <b>90'</b> TIP HEIGHT (27.4m)

# THE GROVE<sup>®</sup> TRAPEZOIDAL<sup>†</sup> BOOM

A LONG REACH  
BOOM OF SUPERIOR  
STRENGTH AND CAPACITY

The Grove Trapezoidal Boom, a major engineering accomplishment in telescoping hydraulic boom design, represents the optimum strength-to-weight ratio for hydraulic crane operation. Compared to conventional booms, the Trapezoidal boom provides greater reach and capacity at full boom and at any working radii. The superior strength and rigidity are directly attributable to the trapezoidal design and the use of very high strength steels. This permits a deeper, wider and lighter boom with greater resistance to lateral and vertical deflection.

Two booms are available for the RT75S; the standard boom consists of a base section, two power-telescoping sections and a "Swingaway" lattice boom extension. The optional boom consists of a base section, two power-telescoping sections, a power pinned fourth section and a "Swingaway" lattice boom extension. Boom elevation is from -4° to 76°.

†Patented Grov feature.



**IF IT'S  
TRAPEZOIDAL  
... IT'S A  
GROVE**



# SPECIFICATIONS

**BOOM** – 34 ft. – 116 ft. (10.4m – 35.4m), 4-section boom; 2 full power trapezoidal sections to 84 ft. (25.6m) plus a 32 ft. (9.7m) "Swingaway" lattice extension. Integral check valves on each telescoping cylinder. \*35 ft. – 142 ft. (10.7m – 43.3m), 5-section boom, 2 full power and 1 power pinned trapezoidal sections to 110 ft. (33.5m) plus a 32 ft. (9.7m) "Swingaway" lattice extension. Integral check valves on each telescoping cylinder. Boom telescope sections are individually controlled. Each boom section is supported on graphite impregnated nylatron wear pads.

**BOOM NOSE** – Four 15 in. (381mm) tread diameter sheaves mounted on heavy duty tapered roller bearings. Removable pin type rope guards permit easy reeving. Rope dead ends on each side of the boom nose. †(Single sheave (15 in. or 381mm tread dia.) auxiliary boom nose mounted to main boom nose with removable pin type rope guard for single part line work.)

**BOOM ELEVATION** – Dual double-acting hydraulic cylinders with integral holding valves; elevation from – 4° to 76°. Combination controls provided for hand or foot operation.

**\*LOAD MOMENT AND ANTI-TWO BLOCK SYSTEM (KRUGER)** – Audio-visual warning in combination with Grove control lever lockout of: hoist up, boom telescope out, and boom down functions.

**\*JIB** – A 24 ft. (7.3m) A-frame section which attaches to the sheave shaft of the 32 ft. (9.7m) swingaway lattice boom extension. The jib can be offset from a minimum of 5° to a maximum of 30° and includes mast, pendant lines, single-rope self-equalizing suspension; no stowable.

**SWING** – Ball bearing swing circle, 360° continuous rotation. Grove Planetary "Glide Swing" with foot operated disc swing brake, hand operated plunger type turntable lock. (\*Non-free swing optional) swing speed 2.6 RPM.

**COUNTERWEIGHT** – Removable, bolted to turntable mast, stationary. Weight varies with hoist configurations . . . 5,300 lb. (2404kg) with no auxiliary, 4,500 lb. (2041kg) with model 15S or 11 SGEGR auxiliary, 3,700 lb. (1678kg) with model 32S auxiliary hoist.

**CAB** – Turntable-mounted on vibration and sound-absorbing rubber grommets, full vision, all steel, fully enclosed, acoustically treated with tinted tempered safety glass throughout (removable front windshield with storage provision and hinged skylight are tinted laminated safety glass), sliding left side door and sliding right side window for ventilation. Full length control levers, fully adjustable operator's seat. Complete engine instrumentation and operating controls. Combination hand and foot controls for engine throttle and boom elevation. All-crane superstructure and outrigger controls, outrigger sight leveling bubble, electronic boom angle indicator with high and low angle presets and audio-visual warning, 20,000 BTU diesel fuel heater, forced hot air defroster, electric windshield wiper, domelight, dashlight, air horn, front cab mounted worklights, door and window locks, 3 1/4 lb. (1.7kg) dry type fire extinguisher.

**CAB INSTRUMENTATION** – Engine oil pressure gauge, engine water temperature gauge, voltmeter, electric fuel gauge, electric tachometer, air pressure gauge, transmission and torque converter oil temperature gauge.

**OUTRIGGERS** – Hydraulic double-box integral with main frame; telescoping beams, vertical jacks with integral check valves and mechanical spin locks on each vertical jack to secure outrigger jacks at any level. Beams extend to

21 ft. (6.4m) centerline-to-centerline, retract to 9 ft. 5 in. (2.9m). Independent or simultaneous control in-out-up-and-down. Outrigger controls in operator's cab. Sequence control arrangement eliminates accidental actuation. 24 in. dia. (610mm) high-strength steel floats with storage racks.

**MAIN FRAME** – All-welded construction with full depth longitudinals braced by cross-members. Frame reinforced at critical points to insure a rigid turntable mounting. Front and rear lifting, towing and tie down lugs are integral with the main frame.

**TRANSMISSION AND TORQUE CONVERTER** – Engine-mounted converter 1.82:1 stall ratio with PTO for hydraulic pumps. Remote mounted full powershift transmission with rear axle disconnect.

**SPEEDS** – 6 forward and 6 reverse.

**AXLES** – Front: Planetary drive/steer mounted rigid to frame. Rear: Planetary drive/steer pivot mounted to allow 0 in. to 10 in. (254mm) oscillation (no-spin optional).

**OSCILLATION LOCKOUTS** – Automatic hydraulic on rear axle. Allows oscillation only with boom over front.

**SERVICE BRAKES** – Full air on all four wheels.  
Size: 20 1/4 in. x 4 in. (514mm x 102mm) with 36 sq. in. (232cm<sup>2</sup>) chambers.

**PARKING BRAKES** – Front and rear axles equipped with spring set air-released emergency/parking axles.

**STEERING** – Front: Power assist hydraulic control.  
Rear: Full hydraulic, tiller bar control. Independent front and rear steer control allows maximum maneuverability.

**TIRES** – 29.5 x 25 – 22 ply wide base; earth-mover type, tubeless. \*26.5 x 25 – 26 ply and 29.5 x 25 – 28 ply wide base; earth-mover type, tubeless.

**\*TOW WINCH** – Braden PD 15 planetary, front-mounted, cab-controlled, 15,000 lb. (6804kg) single line pull and 59 ft./min. (18m/min.) single line speed. Drum rope storage capacity is 340 ft. (103.6m) of 5/8 in. (16mm) dia. rope (less rope and hook).

**HYDRAULIC SYSTEM:**

**RESERVOIR** – 154 gallon (583 liter) capacity, all-steel welded construction with integral baffles, clean-out access and exterior oil level gauge.

**FILTER** – Full flow return line replaceable cartridge with by-pass protection and filter by-pass indicator. 25 Micron rating.

**PUMPS** – 4 main gear pumps. 146 GPM capacity (553 LPM). Power steering pump 18.7 GPM capacity (71 LPM). Pump disconnect level operated from carrier deck.

**CONTROL VALVES** – Precision four-way double-acting with integral load check, main and circuit relief valves. Four individual valve banks permitting simultaneous independent control of four crane functions. Maximum operating pressure 2500 PSI (17.58kg/cm<sup>2</sup>).

**OIL COOLER** – Full flow, fin and tube, oil to air.

**POWER DISTRIBUTION** – (Main hoist, auxiliary hoist boost) (Boom elevation, mid telescope, main hoist boost, auxiliary hoist) (Fly telescope, rear steer, boom elevation boost)(Swing) Model 32S-1716A Auxiliary only.

**MISCELLANEOUS STANDARD EQUIPMENT** – Complete light package, tool box and storage well, fenders, hook-block tie down, ether injection cold starting aid, chassis mounted rear view mirror, asbestos wrapped mufflers.

\*Denotes optional equipment

## HOIST SPECIFICATIONS

DESCRIPTION: Series parallel circuitry and two motors provide both high line pull and speed ranges. Power up and down, equal speed, planetary reduction with integral automatic brake. Hoist drum rotation indicator is standard.		DESCRIPTION: Power up and down, equal speed, planetary reduction with integral automatic brake. Hoist drum rotation indicator is standard.																											
HOIST DATA	MAIN and/or *AUXILIARY HOIST GROVE MODEL 32S-1716A	*AUXILIARY HOIST GROVE MODEL 15S-16B	*AUXILIARY HOIST (CONTROLLED FREE FALL) MODEL 11 SGEGR																										
Drum Dimensions	16 in. diameter (406mm) 16 in. length (406mm) 24 in. flange dia. (610mm)	12 in. diameter (305mm) 16 in. length (406mm) 17.5 in. flange dia. (445mm)	9 in. diameter (229mm) 13 in. length (330mm) 17.5 in. flange dia. (445mm)																										
Performance	<table border="0"> <tr> <td><b>High Speed Range</b></td> <td><b>Low Speed Range</b></td> </tr> <tr> <td>Single line speed</td> <td>Single line speed</td> </tr> <tr> <td>525 FPM</td> <td>265 FPM</td> </tr> <tr> <td>(160m/min)</td> <td>(80.8m/min)</td> </tr> <tr> <td>Single line pull</td> <td>Single line pull</td> </tr> <tr> <td>8,400 lbs.</td> <td>16,800 lbs.</td> </tr> <tr> <td>(3810kg)</td> <td>(7620kg)</td> </tr> </table>	<b>High Speed Range</b>	<b>Low Speed Range</b>	Single line speed	Single line speed	525 FPM	265 FPM	(160m/min)	(80.8m/min)	Single line pull	Single line pull	8,400 lbs.	16,800 lbs.	(3810kg)	(7620kg)	<table border="0"> <tr> <td>Single line speed</td> <td>Single line pull</td> </tr> <tr> <td>206 FPM</td> <td>9,165 lbs.</td> </tr> <tr> <td>(63m/min)</td> <td>(4157kg)</td> </tr> </table>	Single line speed	Single line pull	206 FPM	9,165 lbs.	(63m/min)	(4157kg)	<table border="0"> <tr> <td>Single line speed</td> <td>Single line pull</td> </tr> <tr> <td>290 FPM</td> <td>9,145 lbs.</td> </tr> <tr> <td>(88.4m/min)</td> <td>(4148kg)</td> </tr> </table>	Single line speed	Single line pull	290 FPM	9,145 lbs.	(88.4m/min)	(4148kg)
<b>High Speed Range</b>	<b>Low Speed Range</b>																												
Single line speed	Single line speed																												
525 FPM	265 FPM																												
(160m/min)	(80.8m/min)																												
Single line pull	Single line pull																												
8,400 lbs.	16,800 lbs.																												
(3810kg)	(7620kg)																												
Single line speed	Single line pull																												
206 FPM	9,165 lbs.																												
(63m/min)	(4157kg)																												
Single line speed	Single line pull																												
290 FPM	9,145 lbs.																												
(88.4m/min)	(4148kg)																												
Drum Rope Storage Capacity	**650 Ft. of 3/4 in. dia. rope (198.1m of 19mm)	720 ft. of 1/2 in. dia. rope (219.5m of 13mm) 480 ft. of 5/8 in. dia. rope (146.3m of 16mm)	675 ft. of 1/2 in. dia. rope (205.7m of 13mm)																										
Permissible Single Line Rope Pull	3/4 in. (19mm) 6 x 41 class – 14,605 lbs. (6625kg) 3/4 in. (19mm) 19 x 7 class – 13,700 lbs. (6214kg)	1/2 in. (13mm) 19 x 7 class – 6,150 lbs. (2790kg) 1/2 in. (13mm) 6 x 37 class – 7,200 lbs. (3266kg) 5/8 in. (16mm) 19 x 7 or 6 x 41 class – 7,926 lbs. (3595kg)	1/2 in. (13mm) 19 x 7 class – 6,150 lbs. (2790kg) 1/2 in. (13mm) 6 x 37 class – 7,200 lbs. (3266kg)																										

\*\*6th layer of rope not recommended for hoisting operations

The name Grove and the Trapezoidal shape are registered trademarks of Grove Manufacturing Co.



# SPECIFICATIONS

## ENGINE SPECIFICATIONS

MAKE & MODEL	Detroit Diesel 6V-53N	*Cummins Diesel V555-C200	*Caterpillar 3208 Diesel
TYPE	6 Cylinder O.H.V.	8 Cylinder O.H.V.	8 Cylinder O.H.V.
BORE & STROKE	3.875 in. x 4.50 in. (98mm x 114mm)	4.625 in. x 4.125 in. (117mm x 105mm)	4.5 in. x 5.0 in. (114mm x 127mm)
DISPLACEMENT	318 cu.in. (5212cm <sup>3</sup> )	555 cu.in. (9096cm <sup>3</sup> )	636 cu.in. (10 424cm <sup>3</sup> )
HORSEPOWER (NET)	170 @ 2500 RPM	176 @ 2600 RPM	178 @ 2600 RPM
GOVERNED RPM	2500	2600	2600
TORQUE (NET)	392 lbs. ft. (55kg.m) @ 1500 RPM	380 lbs. ft. (54kg.m) @ 1850 RPM	468 lbs. ft. (65kg.m) @ 1200 RPM
ELECTRICAL SYSTEM	12-Volt, Negative Ground	12-Volt, Negative Ground	12-Volt, Negative Ground
COMBUSTION SYSTEM	2 Cycle with blower	4 Cycle, Naturally Aspirated	4 Cycle, Naturally Aspirated
COOLING SYSTEM	Liquid	Liquid	Liquid
FUEL CAPACITY	60 Gallon (227 liters)	60 Gallon (227 liters)	60 Gallon (227 liters)
ALTERNATOR	65 Amp, 12-volt	58 Amp, 12-volt	55 Amp, 12-volt
BATTERY	(2) 204 A.H., 12-volt	(2) 204 A.H., 12-volt	(2) 204 A.H., 12-volt
AIR CLEANER	Dry Type	Dry Type	Dry Type
AIR COMPRESSOR	7.25 CFM	13.2 CFM	12 CFM
HOURMETER	Yes	Yes	Yes

\*Denotes Optional Equipment

## SPEED AND GRADEABILITY

Forward Drive	Transmission Range	Gear Shift	Maximum Speed		Gradeability @ Stall (%)	Tractive Effort At Stall	
			MPH	KM/H		LBS.	KG.
4 Wheel Drive	Low	1st	2.1	3	74.8	44,311	20 099
4 Wheel Drive	Low	2nd	3.9	6	32.3	23,407	10 617
4 Wheel Drive	Low	3rd	10.0	16	10.0	8,574	3 889
2 Wheel Drive	High	1st	4.8	8	24.8	18,633	8 551
2 Wheel Drive	High	2nd	8.8	14	11.8	9,826	4 457
2 Wheel Drive	High	3rd	21.8	35	3.1	3,615	1 639

NOTE: All performance data is based on standard machine and may vary plus or minus 10% due to variations in engine performance. Gradeability values above 45% are theoretical. Machine should be operated within limits of engine crank case design, 15° (GM), 30° (Cat), 40° (Cummins).

## WORKING WEIGHTS

Standard Machine With	Total Weight		Axle Weight Distribution			
	Lbs.	Kg	Front		Rear	
			Lbs.	Kg	Lbs.	Kg
34-116 ft. (10.4-35.4m) Boom	73,689	33 425	39,566	17 947	34,123	15 478
35-142 ft. (10.7-4.33m) Boom	76,145	34 539	43,808	19 871	32,337	14 668

# DIMENSIONS

TIRE SIZE	"A"	"B"	"C"	"D"	"E"	"F"	BOOM LENGTH	"G"	"H"
29.5 x 25 (1676)	66 in. (2502)	98½ in. (3327)	10 ft. 11 in. (3327)	33 in. (838)	14¼ in. (362)	21 in. (533)	• 34 ft. - 84 ft. (10.36m-25.60m)	16 ft. 11 in. (5156)	43 ft. 2¼ in. (13 164)
26.5 x 25 (1702)	67 in. (2477)	97½ in. (3251)	10 ft. 8 in. (3251)	31 in. (787)	12¼ in. (311)	19 in. (483)	• 35 ft. - 110 ft. (10.67m-33.53m)	18 ft. 1 in. (5512)	44 ft. 4 in. (13 513)

Fender Width - 10 ft. 11 in. (3327)

• 32 ft. (9754) extension stowed

TAIL SWING - 14 ft. (4267)  
TURNING RADIUS - 20 ft. 8 in. (6299)  
OVERALL HEIGHT WITH  
STANDARD TIRES - 12 ft. 6 in. (3810)

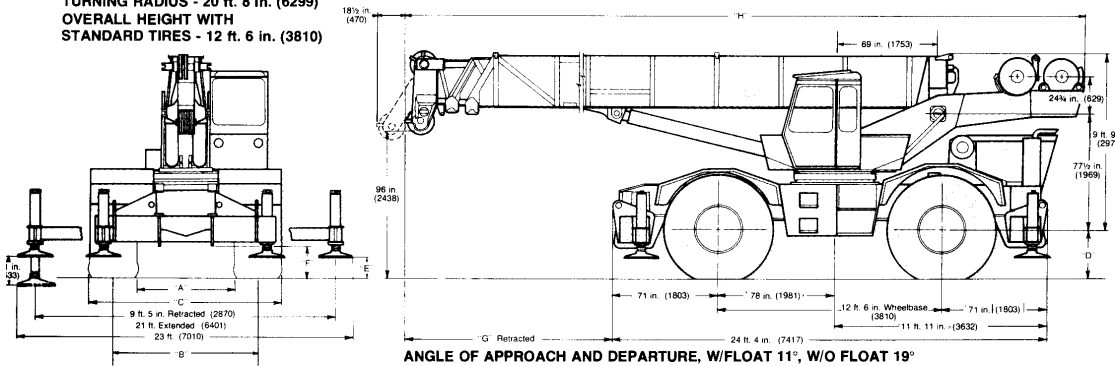

Constant improvement and engineering progress makes it necessary that we reserve the right to make specification, equipment, and price changes without notice. Illustrations shown may include optional equipment and accessories and may not include all standard equipment.

Note: Figures in parentheses ( ) are metric equivalents expressed in millimeters.





## FEATURES

- **CAB WITH A VIEW** . . . operator convenience, always an important factor in Grove cab design, is illustrated at left. Notice the operator's unobstructed view of the load when the skylight is raised and the windshield is removed. There is no overhead cross-member to interfere with visibility. Also, the turntable mounting faces the operator towards the load at all times. Controls are conveniently arranged to assure maximum ease in performing all crane functions. Cab is mounted on vibration and sound absorbing rubber grommets and interior is acoustically treated.

**ALL-WELDED FRAME** of box-beam construction with full depth longitudinals, braced by cross-members and with integral outrigger boxes assures a strong rigid lifting platform.

- **LEVEL QUICKLY ON ANY TERRAIN** with the long thrust vertical jacks which are fitted with integral check valves to retain the jacks in their extended position. In addition to the integral check valve and for added safety, each vertical jack cylinder incorporates the exclusive Grove screw-lock which permits the outrigger jacks to be mechanically secured in any position throughout its stroke. Outriggers are of the double-box beam type and provide a spread of 21 ft. (6.4m). Durable, but lightweight high-strength steel floats are stored in compartments on each side of the machine.

- **TWO SPEED HOIST<sup>†</sup>** . . . a Grove innovation which permits both high line pull and high line speed without changes in lagging or gearing. At the flick of the electropneumatic speedshift, the operator can change from maximum line pull (16,800 lbs.) (7,620kg) to top line speed (525 fpm) (160m/min.) On the RT75S, the optional auxiliary hoist can be the same model as the main hoist providing dual capability.

- **TOOL STORAGE** is provided in a large storage compartment located forward on the chassis.

**EASY MANEUVERABILITY** is provided by 4-wheel steering and 4-wheel drive. To enhance flotation and traction characteristics for rough terrain operation, the RT75S has wide base lug-type earthmover tires.

- **EASIER REEVING** . . . removable pin-type rope guards and negative boom angle permit quick and easy ground level reeving and work on hook block.

**THE KRUGER LOAD MOMENT AND ANTI-TWO BLOCK SYSTEM (Optional)** measures critical operational factors relative to rated capacity and provides a continuous visual display of conditions for the load. An easy-to-read color coded instrument indicates the approach of an overload or two-block condition and should overload or two-block occur, an audio-visual warning alerts the operator; the Grove "control lever lockout system" returns the control levers to neutral and permits the use of only those crane functions that will correct the condition.

**OTHER FEATURES include:** integral check valves or holding valves on all load-bearing cylinders . . . power-shift transmission with 5 speeds forward and reverse . . . automatic oscillation lock-out, and to isolate and reduce operating noise levels, the control cab, engine-transmission package, and engine hood are all rubber shock-mounted.

<sup>†</sup> The Ingersoll Rand Two Speed Hoist and Vertical Jack Lock are patented Grove features.



The "Swing Away" lattice boom extension stows laterally along side the boom base section and swings easily into working position to provide 121' (36.9m) tip height with the standard boom and 147' (44.8m) tip height with the optional boom.



In addition to excellent mobility on all types of terrain, the RT75S features low overall height, low center of gravity, excellent ground clearance and a GVW of approximately 74,000 lbs. (33,566kg).



**WORLD LEADER IN HYDRAULIC CRANES**

**GROVE**  
Division of Walter Kidde & Company, Inc.  
**KIDDE**