

STANDARD COMPONENTS INCLUDE:

Boom, boom rest, boom hoist cylinder, 2-speed winch, load line and 5 ton (4,5 mt) overhaul ball, turret with 2,250 lbs (1,020 kg) counterweight, ride-around operator control station with seat, wireless LMI & ATB protection systems, sub-frame with access ladders and integrated radio remote controlled outriggers, 3-section pump, hydraulic reservoir and oil cooler.

HYDRAULICS

- 8-Bolt direct mounted PTO with SAE C output (factory mounted units only)
- Three section vane pump, SAE C input

Pump Section	2000 RPM	2000 RPM
Shaft End Pump:	41.67 GPM @ 100 PSI	158 LPM @ 100 PSI
Center Pump:	28.33 GPM @ 100 PSI	107 LPM @ 100 PSI
Cover End Pump:	11.67 GPM @ 100 PSI	44 LPM @ 100 PSI

- Hydraulic reservoir - 115 gallon (435 liter) capacity

WARNING SYSTEMS

- Wireless LMI with display and crane function shut-offs for overload protection
- Wireless anti-two block system

OPTIONS

- Single front stabilizer
- 10' (3,1 m) Flatbed - wood or steel
- 24" (610 mm) Bulkhead
- 31' (9,5 m) 1-Section fixed jib
- 30'-6" (9,3 m) - 55' (16,8 m) 2-Section telescopic jib
- 5/8" (15,9 mm) Diameter 6 x 25 EIPS IWRC wire rope
- Auxiliary winch same as main, includes rooster sheave
- Auxiliary lower sheave block for 7 to 8 part line
- Load block - 1, 3 & 5 sheave options
- Operator cab with diesel heater, air conditioner (hydraulic) upgrade option

BOOM

- 40 Ton (36,3 mt) capacity @ 5' (1,5 m) radius
- 5-Section 124' (37,6 m) proportional boom
- 5-Sheave quick reeve boom point

HOIST

- Maximum theoretical line speed 453 fpm (138 mpm)
- Maximum theoretical bottom-layer line pull 13,050 lb (5,919 kg)
- Wire Rope – 380' (115,8 m) 5/8" (15,9 mm) diameter rotation resistant

In order to ensure continuous improvement, Manitex reserves the right to change design and specifications without notice.

- Hose reel - boom mounted
- Toolboxes
 - 24" L x 20" W x 18" H (610 mm x 508 mm x 457 mm)
 - 48" L x 18" W x 18" H (1220 mm x 457 mm x 457 mm)
- 2-Person gravity leveled non-rotating basket - 600 lb (272 kg) capacity
- 2-Person gravity leveled rotating (manual) basket - 1,200 lb (544 kg) capacity
- 4-Function radio remote crane control system 900 MHz
- 4-Function radio remote crane control system 433 MHz
- Three-section gear pump, SAE C input

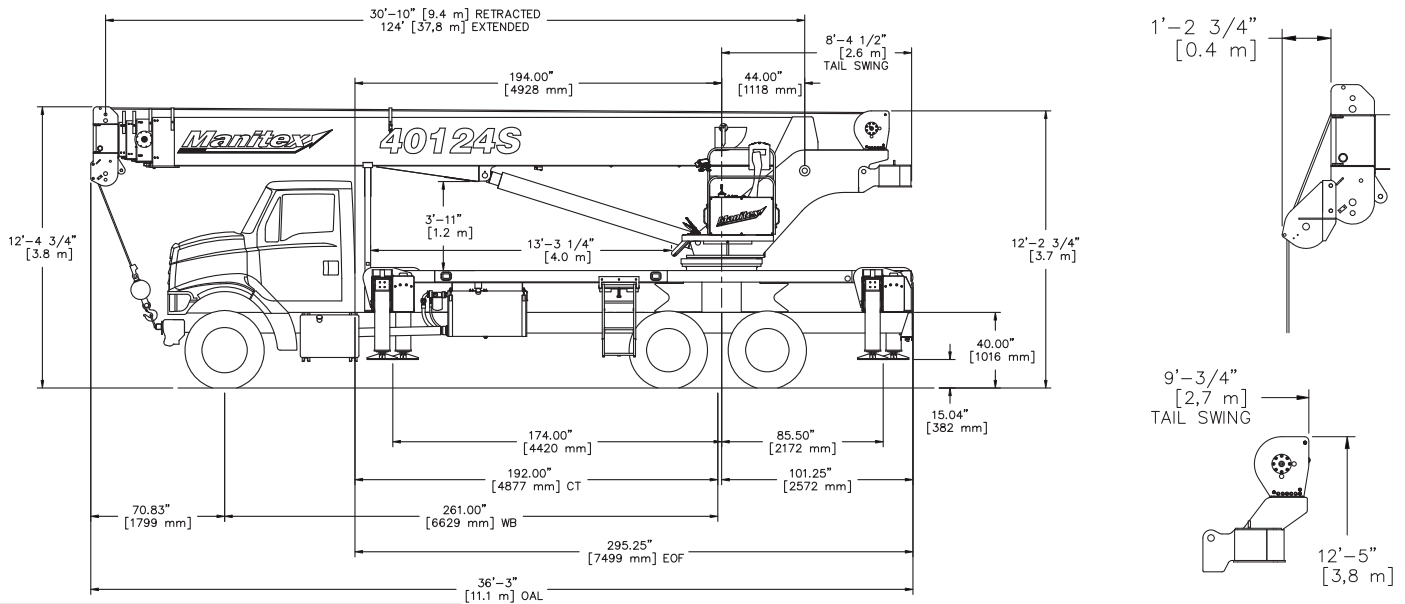

CHASSIS DATA 40124S

Wheelbase (WB)	261" 6 629 mm
Cab to Tandem (CT)	192" 4 877 mm
Cab to End of Frame (EOF)	295" 7 493 mm
Frame Section Modulus at 180°/360° Area of Operation	25.0 in ³ 110,000 psi 758 422 kPa
Front Axle Gross Weight Rating	20,000 lb 9 072 kg
Rear Axle Gross Weight Rating	40,000 lb 18 144 kg
Minimum Truck Axle Weight - Front**	9,200 lb 4 173 kg
Minimum Truck Axle Weight - Back**	8,300 lb 3 765 kg
Nominal Frame Width	34" 864 mm

*Frame section modulus at 360° area of operation requires front bumper stabilizer. **Minimum chassis weight is required to meet 85% stability requirements. Chassis data is general - not for engineering. Some dimensions depend on truck selection.

WEIGHTS 40124S

Crane Without Cab	31,329 lb 14 211 kg
Cab Alone	575 lb 261 kg
Flat Bed 10' (3,10 m)	1,000 lb 454 kg
Fixed Jib 31' (9,50 m)	850 lb 386 kg

MAXIMUM TIP HEIGHT (A) 40124S

Configuration	Boom 124' 37,8 m
Extended Boom	132' 4" 40,3 m
Fixed or Retracted Jib	163' 7" 49,9 m
Extended Jib	187' 0" 57,0 m

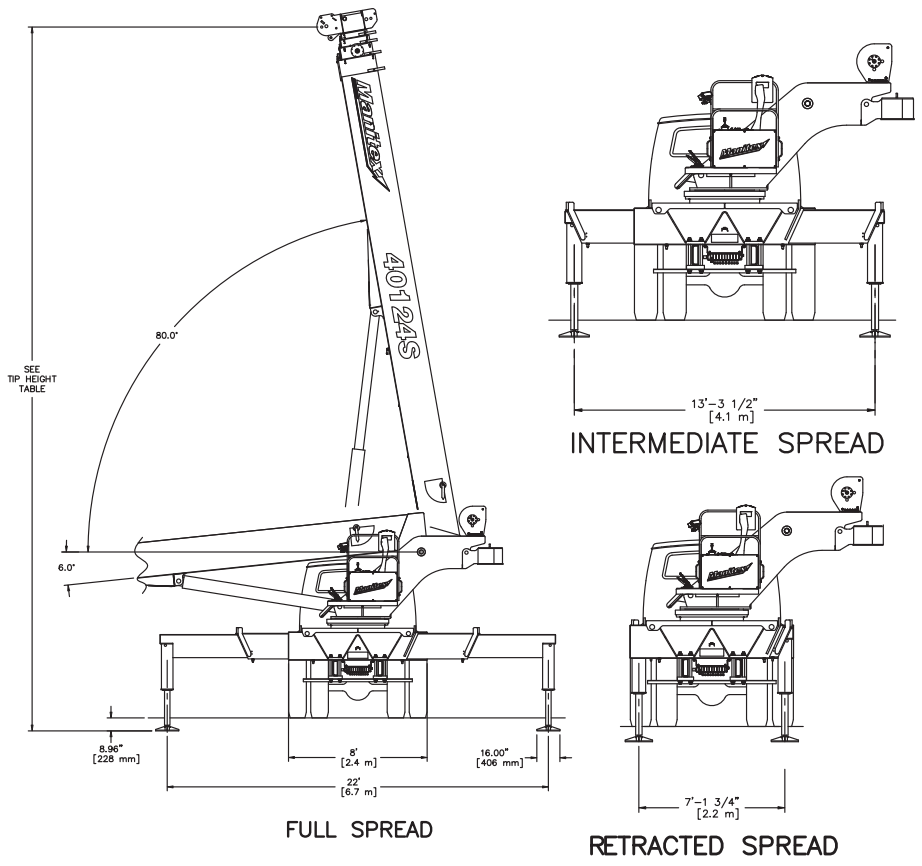

INTERMEDIATE SPREAD

FULL SPREAD

RETRACTED SPREAD