



STAR 13

Compact

- Compact dimensions allow the Star 13 to be stored and transported easily
- Travels through standard doorways and in elevators

Practical and Maneuverable

- Narrow width and a very tight turning radius provide excellent maneuverability
- Can be driven at full height for increased productivity

Safe and comfortable

- With its proportional controls the Star 13 is smooth and comfortable to drive





STAR 13

VERTICAL MASTS

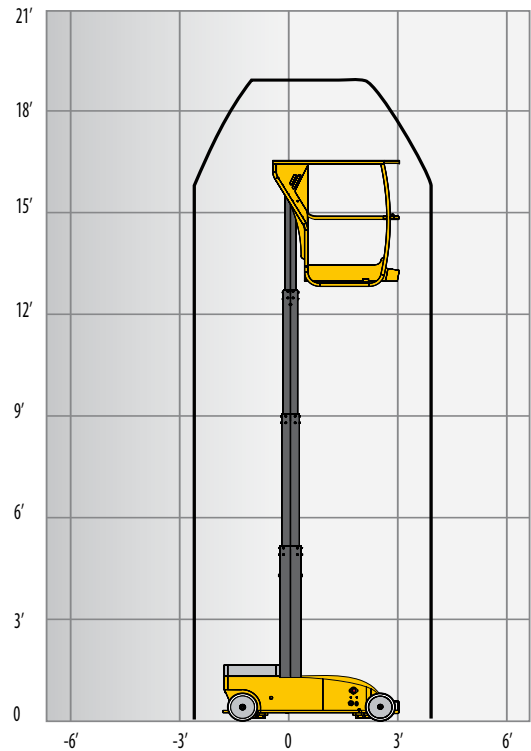

TECHNICAL DATA

STAR 13

Working height	19 ft 1 in
Platform height	13 ft 1 in
Horizontal outreach	N/A
Lift capacity	400 lbs
Platform size	2 ft 7 in x 2 ft 1 in
Picking tray size	0 ft
Picking tray lift capacity	0 lbs
A Length	4 ft 11 in
B Width	2 ft 5 in
C Height - stowed	5 ft 5 in
Tailswing	N/A
D Wheelbase	3 ft 10 in
E Ground clearance	3 in
Drive speed	0.3 - 3.1 mph
Turning radius - outside	4 ft 11 in
Turntable rotation	N/A
Gradeability	20 %
Tires	10x3 in
Batteries	24 V - 180 Amph (C5)
Weight	1,786 lbs

STANDARD EQUIPMENT

- Battery charger 110V / 60 Hz
- Electric proportional controls with soft progressive driving
- DC motor
- 2 front steering wheels
- 2 rear driving wheels
- Deep-cycle batteries
- Battery charge indicator
- Non-marking tires
- Manual brake release
- Hour meter
- AC power to platform
- Electric horn
- Emergency stop buttons at cage and ground level
- Lifting eye
- Fixed pothole protection
- Tie down points
- Tilt alarm

OPTIONS AND ACCESSORIES

- Alarm package (travel and descent)
- Motion alarm (travel only)
- Flashing light with on/off switch
- Synthetic oil
- Break release remote control
- Hydraulic oil in tank and circuit for cold countries (for use below -15°C)

