

Specifications

Hydraulic Truck Terrain Crane

HTT-8670LB

70-ton (63.5 metric tons)

Long Boom

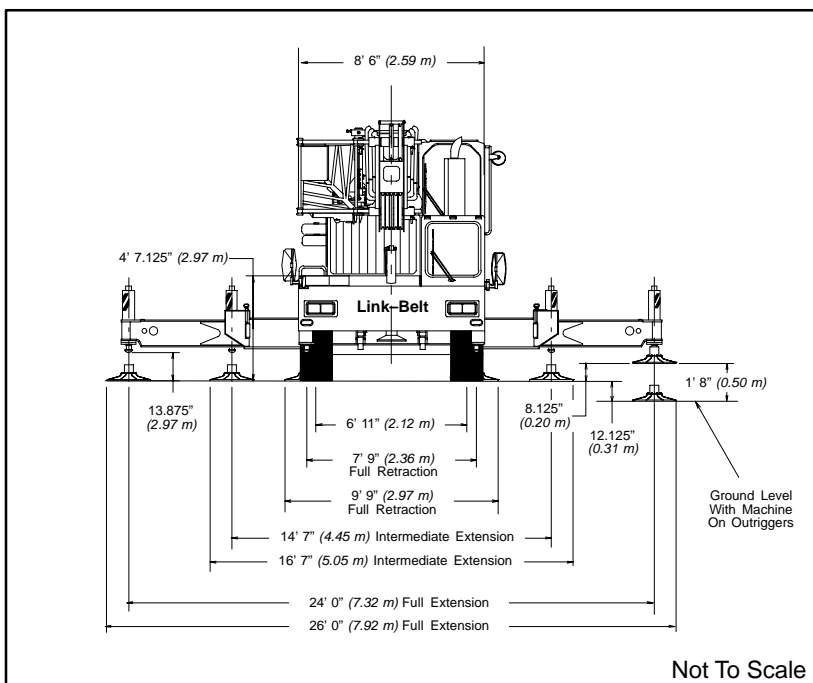
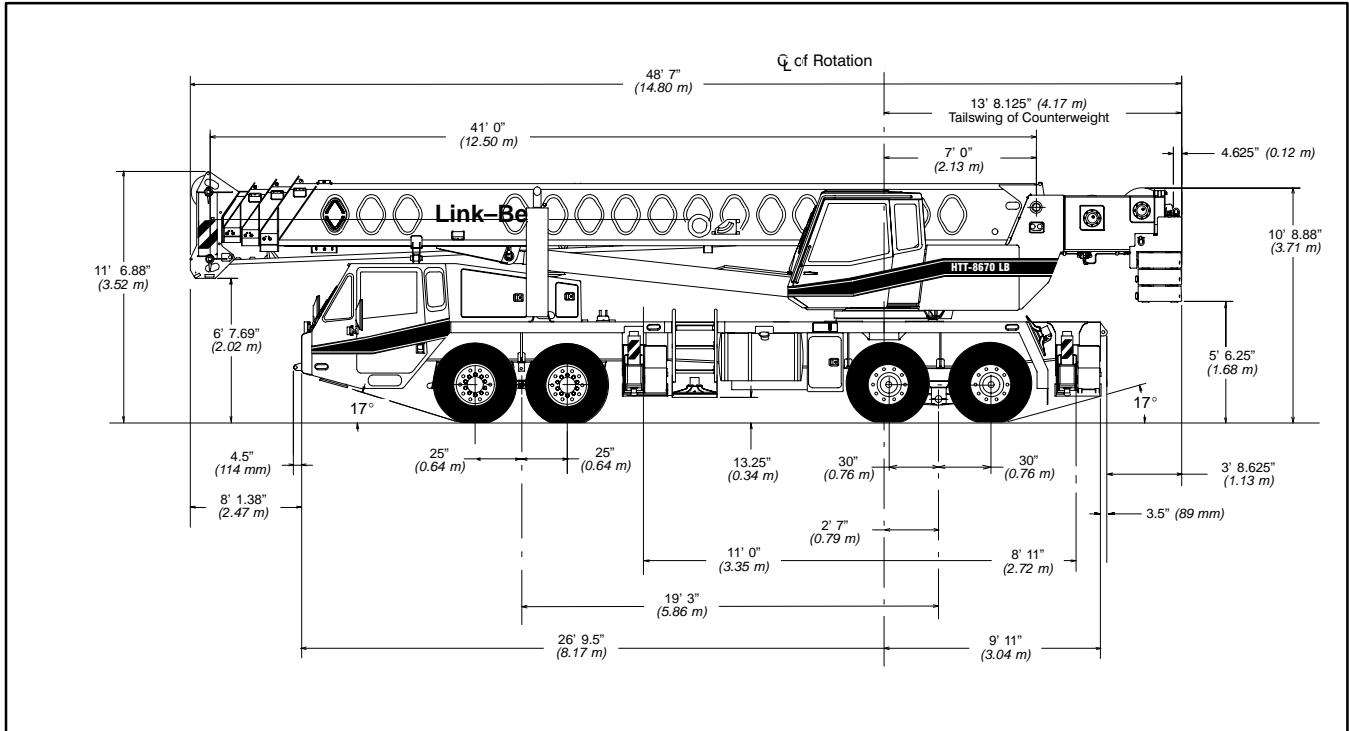

General Dimensions	feet	meters
Front Steer		
Turning radius (wall to wall)	51' 2.75"	15.61
Turning radius (curb to curb)	41' 10.5"	12.76
All-Wheel Steer		
Turning radius (wall to wall)	38' 1.43"	11.62
Turning radius (curb to curb)	28' 7.25"	8.72
Ground clearance	13.25"	0.34

Upper Structure

■ Boom

Patented Design

- Boom side plates have diamond shaped impressions for superior strength to weight ratio and 100,000 p.s.i. (689.5 MPa) steel angle chords for lateral stiffness.
- Boom telescope sections are supported by top, bottom and adjustable side wear shoes to prevent metal to metal contact.

Boom

- 41' – 127' (12.50 – 38.71 m) four-section full power boom
- Two mode boom extension
- The basic mode is the full power, synchronized mode of telescoping all sections proportionally to 127' (38.71 m).
- The exclusive "A-max" mode (or mode 'A') extends only the inner mid section to 69.6' (21.21 m) offering increased capacities for in-close, maximum capacity picks.
- Mechanical Boom Angle Indicator

Boom Head

- Five 16.5" (0.42 m) root diameter nylon sheaves with a fifth nylon sheave available to handle up to ten parts of wire rope.
- Easily removable wire rope guards
- Rope dead end lugs provided on each side of boom head
- Boom head designed for quick reeve of hook block
- Fly pinning alignment tool

Boom Elevation

- One Link-Belt designed hydraulic cylinder with holding valve and bushing in each end.
- Hand control for controlling boom elevation from -3° to +78°.

Optional Auxiliary Lifting Sheave

- Single 16.5" (0.42 m) root diameter nylon sheave with removable wire rope guard, mounted to boom
- Use with one or two parts of line off the optional front winch
- Does not affect erection of fly or use of main head sheaves for multiple reeving.

Optional

- 40-ton (36.29 mt) quick-reeve hook block
- 60-ton (54.43 mt) quick-reeve hook block
- 70-ton (63.5 mt) quick-reeve hook block
- 8.5-ton (7.7 mt) hook ball
- Boom floodlight

■ Fly

Optional

- 39.5' (12.04 m) One-piece lattice fly, stowable, offsettable to 2°, 20° and 40°.
- Lugs to allow for second section.
- 39.5' – 67' (12.04 – 20.42 m) Two-piece (bifold) lattice fly, stowable, offsettable to 2°, 20° or 40°.

■ Cab and Controls

Environmental Ultra-Cab™

- Laminated fibrous composite material; isolated from sound with acoustical fabric insulation.

- Windows are tinted and tempered safety glass
- Sliding rear and right side windows and swing-up roof window for maximum visibility and ventilation
- Slide-by-door opens to 3' (0.91 m) width
- Six-way adjustable seat, with seat belt, for maximum operator comfort
- Hand-held outrigger controls and sight level bubble located on right side of cab
- Diesel cab heater
- Pull-out Cabwalk™
- Audible swing alarm
- Backup alarm
- Fire extinguisher
- 12-volt accessory outlet
- Electric windshield wiper
- Windshield washer
- Top hatch window wiper
- Circulating fan
- Warning horn
- Dome light
- Cup holder
- Sun screen
- Hand throttle
- Mirrors
- Defroster fan

Optional

- Amber strobe light
- Amber rotating beacon
- Hydraulic heater
- Air conditioning

Controls

Hydraulic controls (joystick type) for:

- Swing
- Optional auxiliary winch
- Main winch
- Boom hoist

Foot controls for:

- Boom telescope
- Swing brake
- Engine throttle

Optional

- Auxiliary winch
- Single axis controls

Cab Instrumentation

Cornerpost-mounted gauges for:

- Hydraulic oil temperature
- Audio/Visual warning system
- Tachometer
- Voltmeter
- Water temperature
- Oil pressure
- Fuel

■ Rated Capacity Limiter

- **Microguard 434** Graphic audio-visual warning system built into dash with anti-two block and function limiters.

Operating data available includes:

- Machine configuration.
- Boom length
- Head height
- Allowed load
- % of allowed load
- Boom angle
- Radius of load
- Actual load

Presetable alarms include:

- Maximum and minimum boom angles
- Maximum tip height
- Maximum boom length
- Swing left/right positions
- Operator defined area alarm is standard.
- Anti-two block weight designed for quick reeve of hookblock.

Optional

- **Internal RCL light bar:** Visually informs operator when crane is approaching maximum load capacity with a series of green, yellow and red lights.
- **External RCL light bar:** Visually informs ground crew when crane is approaching maximum load capacity kickouts and pre-settable alarms with a series of three lights; green, yellow and red.

■ Swing

- Bi-directional hydraulic swing motor mounted to a planetary reducer for 360° continuous smooth swing at 1.7 r.p.m.
- **Swing park brake** – 360°, electric over hydraulic (spring applied, hydraulic released) multi-disc brake mounted on the speed reducer. Operated by toggle switch in overhead control console.
- **Swing brake** – 360°, foot operated, hydraulic applied disc brake mounted on the speed reducer.
- **Swing lock** – Standard; two position travel lock operated from the operator's cab.
- **Counterweight**
 - Standard – Pinned to upper structure frame. 12,000 lbs. (5 443 kg) three-piece design (4,000 lbs. each).
 - Optional – 16,000 lbs. (7 258 kg) five-piece design. (Dolly required for five piece arrangement).
- Hydraulically controlled counterweight removal, standard. Counterweight sections may be lowered on and pinned to carrier deck to balance axle loadings for travel.

Optional

- 360° (Pawl-in-Gear) swing lock. Meets New York City requirements

■ Hydraulic System

Main Pump

- Two gear pump with a total of five sections
- Combined pump capacity of 152 gpm (575 lpm). Powered by carrier engine with pump disconnect.
- Spline type pump disconnect, engaged / disengaged from carrier cab
- Maximum system operating pressure is 3,500 psi (24 133 kPa)

Pilot Pressure / Counterweight Removal Pump

- Pressure compensated piston pump powered by carrier engine with pump disconnect. Operates at 1,500 psi (10 343 kPa) maximum.

Steering / Fifth Outrigger Pump

- Single gear type pump, 8 gpm (30 lpm). Powered by carrier engine through front gear housing. Max. pump operating pressure is 2,000 psi (13 790 kPa).
- Reservoir – 169 gallon (639.7 L) capacity. One diffuser for deaeration.

Filtration

- One, 10–micron filter located inside hydraulic reservoir
- Accessible for easy replacement

Control valves

- Six separate pilot operated control valves allow simultaneous operation of all crane functions.

Load Hoist System

Standard

- 2M main winch with grooved lagging
- Two–speed motor and automatic brake

- Power up/down mode of operation
- Hoist drum cable followers
- Bi–directional piston–type hydraulic motor driven through planetary reduction unit for positive control under all load conditions.
- Asynchronous parallel double crossover grooved drums minimize rope harmonic motion.
- Winch circuit control provides balanced oil flow to both winches for smooth, simultaneous operation.
- Rotation resistant wire rope
- Drum rotation indicators

Line Pulls and Speeds

- Maximum available line pull 16,506 lbs. (7 484 kg) and maximum line speed of 513 f.p.m. (156 m/min) on 16" (0.41 m) root diameter grooved drum.

Optional

- 2M auxiliary winch with two–speed motor, automatic brake, and winch function lock-out. Power up/down modes.
- Hoist drum cable followers
- Third wrap indicators

Carrier

Type

- 8' 6" (2.59 m) wide, 231" (5.87 m) wheel-base. 8 x 4 drive – standard

Frame

- 100,000 p.s.i. (689.5 MPa) steel, double walled construction with integral 100,000 p.s.i. steel outrigger boxes.

Optional

- Carrier mounted storage box
- Pintle hook
- Electric and air connections for trailers and boom dollies

Axles

Front

- Tandem, 84.38" (2.14 m) track

Rear

- Tandem, 81.89" (2.08 m) track. 7.29 to 1.0 ratio with interaxle differential and cross axle lock capability.

Suspension

Front axle

- Leaf spring suspension

Rear axle

- Air–ride, bogie beam type, suspension

Wheels

Standard

- Hub piloted aluminum disc
- Spare tire and wheel assemblies

Tires

Standard Front and Rear

- 445/65R22.5 (Load range "L") single tubeless radials

Brakes

Service

- Full air brakes on all wheel ends with automatic adjusters. Dual circuit with modulated emergency brakes.
 - Front – 16.5 x 6 S–Cam brakes
 - Rear – 16.1 x 7 Wedge brakes

Parking/Emergency

- One spring set, air released chamber per rear axle end
- Parking brake applied with valve mounted on carrier dash

- Emergency brakes apply automatically when air drops below 40 psi (275.8 kPa) in both systems

Steering

Four steer capabilities; front, rear, all–wheel and "crab" steer.

Front

- Sheppard rack and pinion design

Rear

- Hydraulic power cylinders

Transmission

Standard – Eaton RTO–14909ALL; 11 speeds forward, 3 reverse.

Electrical

- Four, 12–volt batteries provide 12–volt starting
- 2,800 cold cranking amps available
- 12–volt operating system, 130–amp alternator

Lights

- Four dual beam sealed headlights
- Front, side, and rear directional signals
- Stop, tail and license plate lights
- Rear and side clearance lights
- Hazard warning lights

Outriggers

- Three position operation capability
- Four hydraulic, telescoping beam and jack outriggers
- Vertical jack cylinders equipped with integral holding valve
- Beams extend to 24' (7.32 m) centerline–to–centerline and retract to within 8' 6" (2.59 m) overall width.
- Equipped with stowable, lightweight 24" (0.61 m) diameter aluminum floats.
- Standard fifth outrigger, 14.75" (0.37 m) self storing steel pad is operable from ground or operator's cab.
- Hand–held controls and sight level bubble located in operators cab and on carrier deck.

Confined Area Lifting Capacities (CALC™) System

- The crane is operational in one of the three outriggers positions and operational in confined areas in two positions (intermediate and full retraction).

The three outrigger positions are:

- Full extension – 24' 0" (7.32 m)
- Intermediate position – 14' 7" (4.45 m)
- Full retraction – 7' 9" (2.36 m)
- Capacities are available with the outrigger beams in the intermediate and full retraction positions.
- When the outrigger position levers (located on the outrigger beams) are engaged, the operator can set the crane in the intermediate or full retraction outrigger position without having to leave the cab.

Carrier Cab

- One–man cab of laminated fibrous composite material acoustical insulation with cloth covering.

Equipped with:

- Air–ride adjustable operator's seat with seat belt
- Tilting and lockable steering wheel
- Door and windows locks
- Left–hand and right–hand rear view mirrors
- Sliding right–hand and rear tinted windows
- Roll up/down left–hand tinted window
- Desiccant–type air dryer
- Steps to upper, lower cab and rear carrier
- 120–volt electric engine block heater
- Back–up warning alarm
- Tow hooks and shackles
- Aluminum fenders and mud flaps
- Carrier mounted outrigger controls with throttle control
- Electric windshield wiper and washer
- Rotating beacon
- Horn
- Fire extinguisher
- 36,000 BTU heater
- Dome light
- High beam light switch
- Travel lights
- Mud flaps
- Ashtray
- Defroster
- Cruise control

Cab instrumentation

- Illuminated instrument panel speedometer.
- Tachometer
- Fuel gauge
- Oil pressure gauge
- Turn signal indicator
- Water temperature gauge
- Front and rear air pressure gauges
- Audio/visual warning system
- Check engine and stop engine lights
- Automotive type ignition
- Hourmeter
- Fuses
- Odometer
- Voltmeter

Optional

- Amber strobe light
- Air conditioning

Carrier Speeds *(Manual Transmission – Standard tires)*

Gear	High				Low					Deep reduction		Hi rev.	Lo rev.	Deep reduction	Deep reduction @ 700 rpm	Deep reduction @ 700 rpm
	8	7	6	5	4	3	2	1	Low	LL2	LL1	Rev.	Rev.	Rev.	LL1	Rev.
Ratio	0.73	1.00	1.38	1.95	2.77	3.79	5.23	7.41	16.30	11.85	26.08	3.43	13.03	20.85	26.08	20.85
Speed	mph	51.92	37.90	27.47	19.44	13.68	10.00	7.25	5.12	3.20	2.33	1.45	9.13	2.41	1.82	0.61
	km/hr.	83.6	61.0	44.2	31.3	22.0	16.1	11.7	8.2	5.1	3.7	2.3	14.7	3.9	2.9	0.98

Engine

Engine – standard	Detroit Diesel Series 60 12.7 L
Cylinders – cycle	6 / 4
Bore	5.12" (0.13 m)
Stroke	6.30" (0.16 m)
Displacement	778 cu. in. (12 751 cm ³)
Maximum brake hp.	365 @ 1,800 rpm; 350 @ 2,100 rpm
Peak torque	1,350 ft. lbs. (1 831 J) @ 1,200 rpm
Electric system	12-volt neg. ground / 12 volt starting
Fuel capacity	85 gallons (321.8 L)
Alternator	12 volt, 130 amps
Crankcase capacity	32 qts. (30 L)

• Engine brake – standard • Ether injection starting package – optional

Axle Loads

Base machine with standard 41' – 127' (12.50 – 38.71 m) four-section boom, 2M main winch with 2-speed hoisting and power up/down, 670' (204.21 m), 3/4" (19 mm) wire rope, 8 x 4, 8.5' (2.59 m) carrier with Detroit Diesel Series 60 engine, 85 gal. (321.8 L) fuel and no counterweight.	G.V.W. ¹		Upper Facing Front			
	lbs.	kg.	Front Axle		Rear Axle	
			lbs.	kg.	lbs.	kg.
	78,294	35 514	37,079	16 819	41,216	18 695
Cold weather starting aids – propane and ether	40	18	57	26	-17	-8
Carrier mounted aluminum storage box	57	26	16	7	41	19
Driver in carrier cab	200	91	254	115	-54	-24
Pintle hook w/air and electrical hook-ups	30	14	-12	-5	42	19
Air conditioning in carrier cab	100	45	127	57	-27	-12
Power up/down winch with 670' (204 m) rope – front	899	408	-290	-132	1,189	539
Hydraulic heater	170	77	1	0.5	169	77
Air conditioning in upper cab	120	54	-4	-2	124	56
One slab of counterweight on upper	4,000	1 814	-2,140	-971	6,140	2 785
Two slabs of counterweight on upper	8,000	3 628	-4,281	-1 942	12,281	5 571
Three slabs of counterweight on upper	12,000	5 443	-6,421	-2 913	18,421	8 356
Three slabs of counterweight on upper plus two cheek weights	16,000	7 257	-8,561	-3 883	24,561	11 140
Fly brackets on boom base section for fly options	160	72	147	68	11	5
39.5' (12.04 m) offsettable fly with tip lugs and anti-two block weight – stowed	1,602	727	1,538	698	64	29
39.5' – 67' (12.04 – 20.42 m) two-piece fly and anti-two block weight – stowed	2,380	1 080	1,995	905	385	175
Floodlight to front of boom base section	10	5	17	8	-7	-3
40-ton (36.3 mt) hookblock at front bumper	720	327	1,175	533	-455	-206
70-ton (63.5 mt) hookblock at front bumper	1,400	635	2,284	1 036	-884	-401
Hookball to front bumper	360	163	587	266	-227	-103
Auxiliary lifting sheave	125	57	230	104	-105	-48

	Front axle		Rear axle	
Transfer one slab of counterweight to carrier deck	5,333	2 419	-5,333	-2 419
Transfer two slabs of counterweight to carrier deck	10,666	4 828	-10,666	-4 838
Transfer three slabs of counterweight to carrier deck	15,999	7 257	-15,999	-7 257

¹ Adjust gross vehicle weight & axle loading according to component weight. Note: All weights are ± 3%

Axle	Max. Load @ 65 mph. (105 km/h)
Front	46,400 lbs. (21 047 kg) – aluminum disc wheels with 445/65R22.5 tires
Rear	49,200 lbs. (22 317 kg) – aluminum disc wheels with 445/65R22.5 tires