

Model 3216 Crane

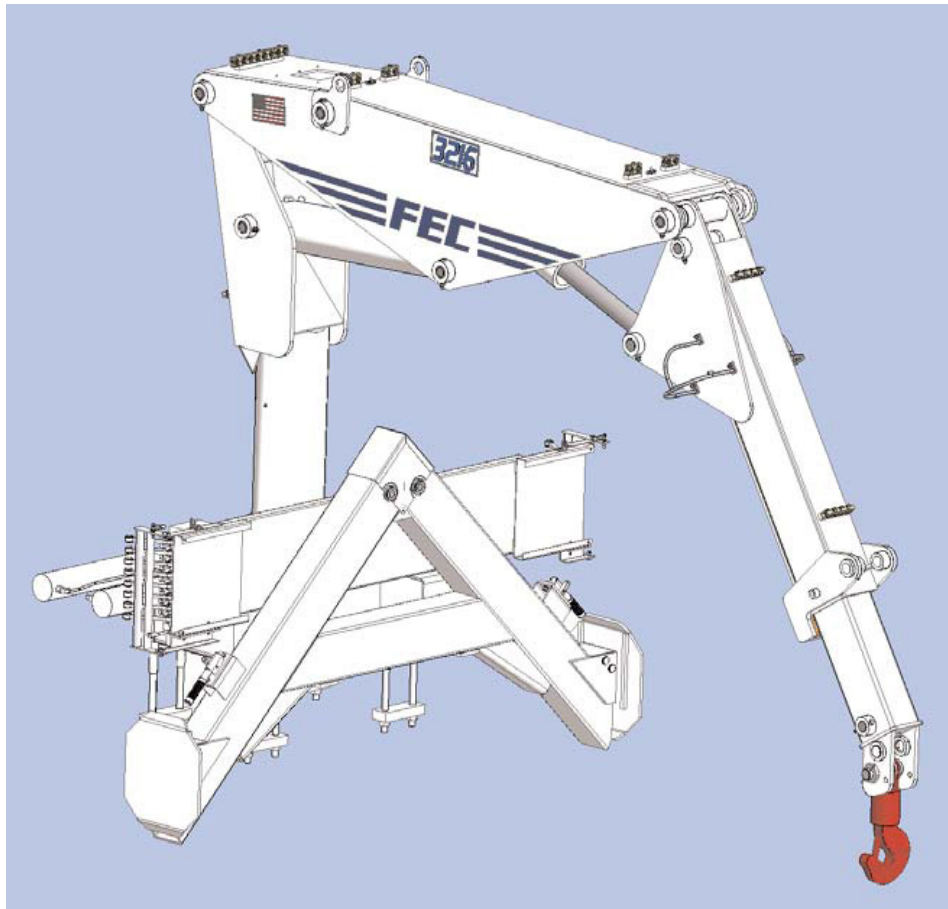

- Center Crane mounting
- "A"-Frame outriggers
- Load holding valves on all lift cylinders.
- Overload protection on main control valve.
- Chrome plated cylinder rods and tubes.
- Plated pivot pins, bolted for extra security.
- Self-lubricating bearing surfaces on all slide tubes.

160,000 ft. lbs. Rating

Crane Capacity Rating:	16,000 lbs.
Maximum Reach:	16'-6"
Crane Weight:	5,840 lbs.
Chassis RBM Required:	2,070,000 in. lbs.